

READ THIS FIRST



Model G9961

*****IMPORTANT UPDATE*****

**For Machines Mfd. Since 09/24
and Owner's Manual Revised 11/03**

For questions or help with this product contact Tech Support at (570) 546-9663 or techsupport@grizzly.com

The following changes were recently made since the owner's manual was printed:

- Labels and parts have changed.

Aside from this information, all other content in the owner's manual applies and **MUST** be read and understood for your own safety. **IMPORTANT: Keep this update with the owner's manual for future reference.**

For questions or help, contact our Tech Support at (570) 546-9663 or techsupport@grizzly.com.

Revised Parts

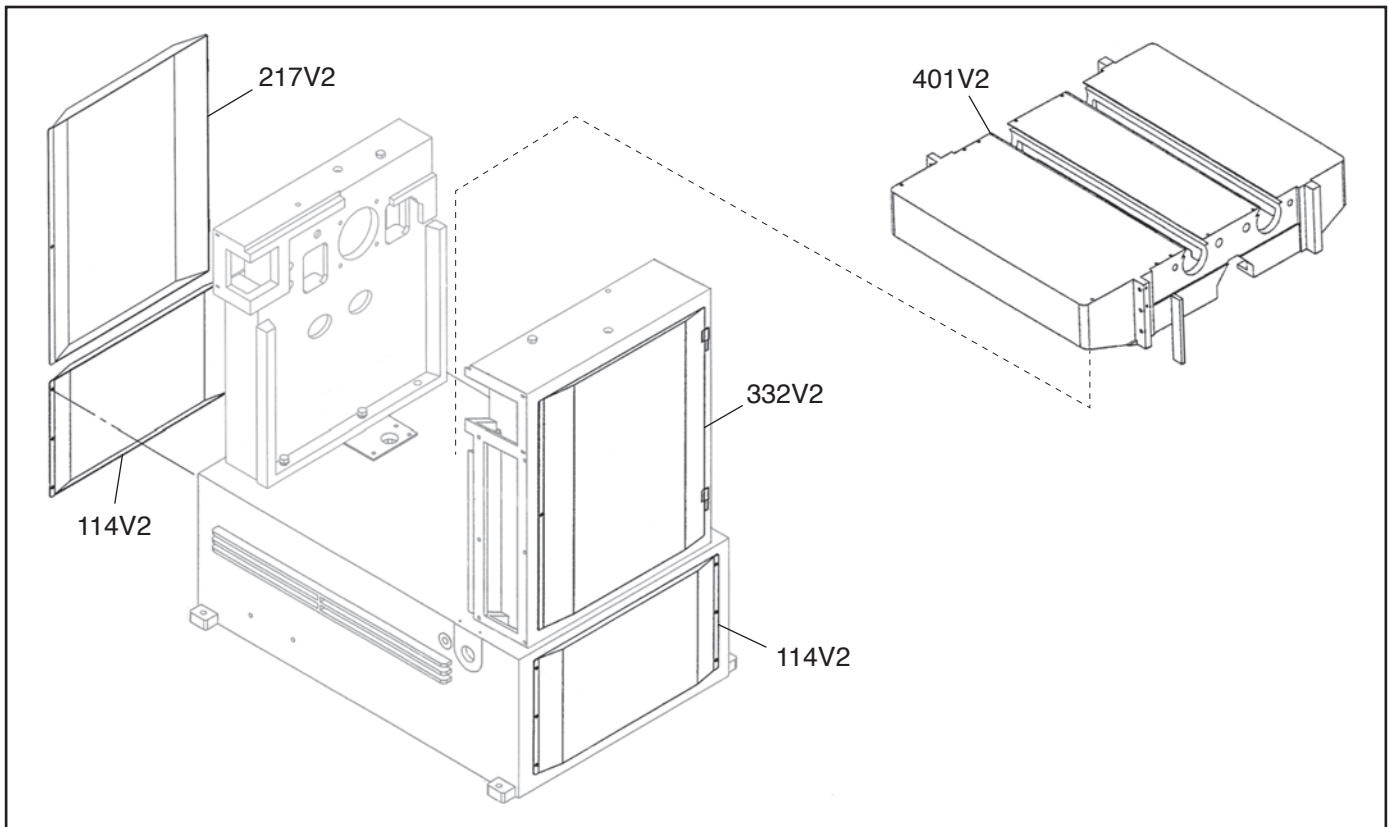

REF	PART #	DESCRIPTION
114V2	P99610114V2	CABINET DOOR V2.09.24
217V2	P99610217V2	LEFT WALL DOOR V2.09.24

REF	PART #	DESCRIPTION
332V2	P99610332V2	RIGHT WALL DOOR V2.09.24
401V2	P99610401V2	TABLE 24" MODEL V2.09.24

COPYRIGHT © SEPTEMBER, 2024 BY GRIZZLY INDUSTRIAL, INC.
**WARNING: NO PORTION OF THIS MANUAL MAY BE REPRODUCED IN ANY SHAPE
OR FORM WITHOUT THE WRITTEN APPROVAL OF GRIZZLY INDUSTRIAL, INC.**
#JA23372 PRINTED IN TAIWAN

Labels & Cosmetics

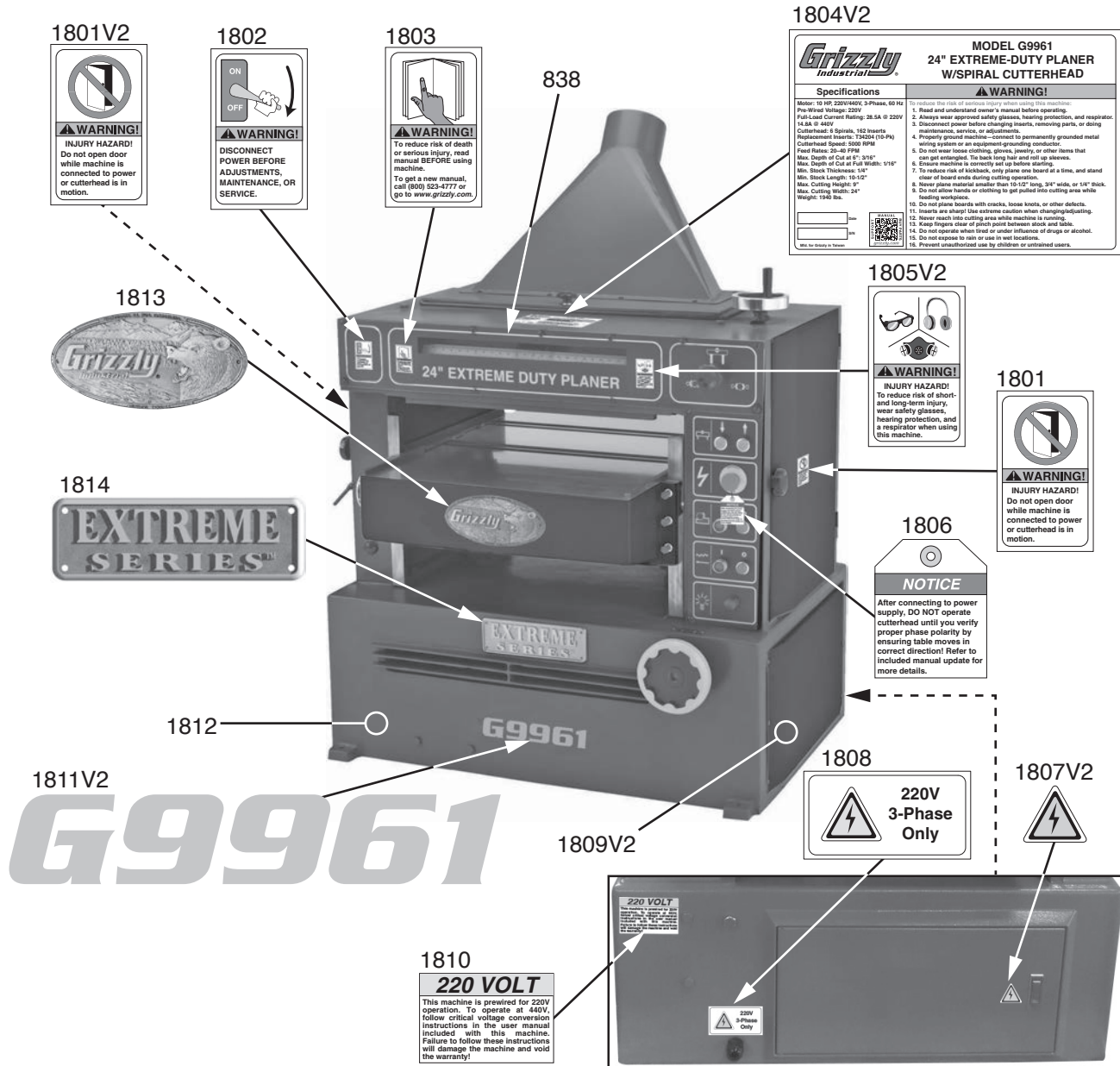

REF	PART #	DESCRIPTION
838	P99610838	SCALE PLATE (24")
1801V2	P99611801V2	DO NOT OPEN DOOR LABEL V2.09.24
1802	P99611802	DISCONNECT POWER 110V LABEL
1803	P99611803	READ MANUAL LABEL
1804V2	P99611804V2	MACHINE ID LABEL V2.09.24
1805V2	P99611805V2	EYE/EAR/LUNG PROTECTION LABEL
1806	P99611806	3-PHASE CONNECTION NOTICE LABEL
1807V2	P99611807V2	ELECTRICITY LABEL V2.09.24

REF	PART #	DESCRIPTION
1808	P99611808	220V 3-PHASE LABEL
1809V2	P99611809V2	TOUCH-UP PAINT, GLOSSY BLACK
1810	P99611810	PREWIRED 220V LABEL
1811V2	P99611811V2	MACHINE NUMBER LABEL V2.09.24
1812	P99611812	TOUCH-UP PAINT, GRIZZLY GREEN
1813	P99611813	GRIZZLY NAMEPLATE
1814	P99611814	EXTREME SERIES NAMEPLATE

⚠ WARNING

Safety labels help reduce the risk of serious injury caused by machine hazards. If any label comes off or becomes unreadable, the owner of this machine **MUST** replace it in the original location before resuming operations. For replacements, contact (800) 523-4777 or www.grizzly.com.

BUY PARTS ONLINE AT GRIZZLY.COM!
Scan QR code to visit our Parts Store.



G9740/G9740Z/G9967/G9967Z/G9741/G9961

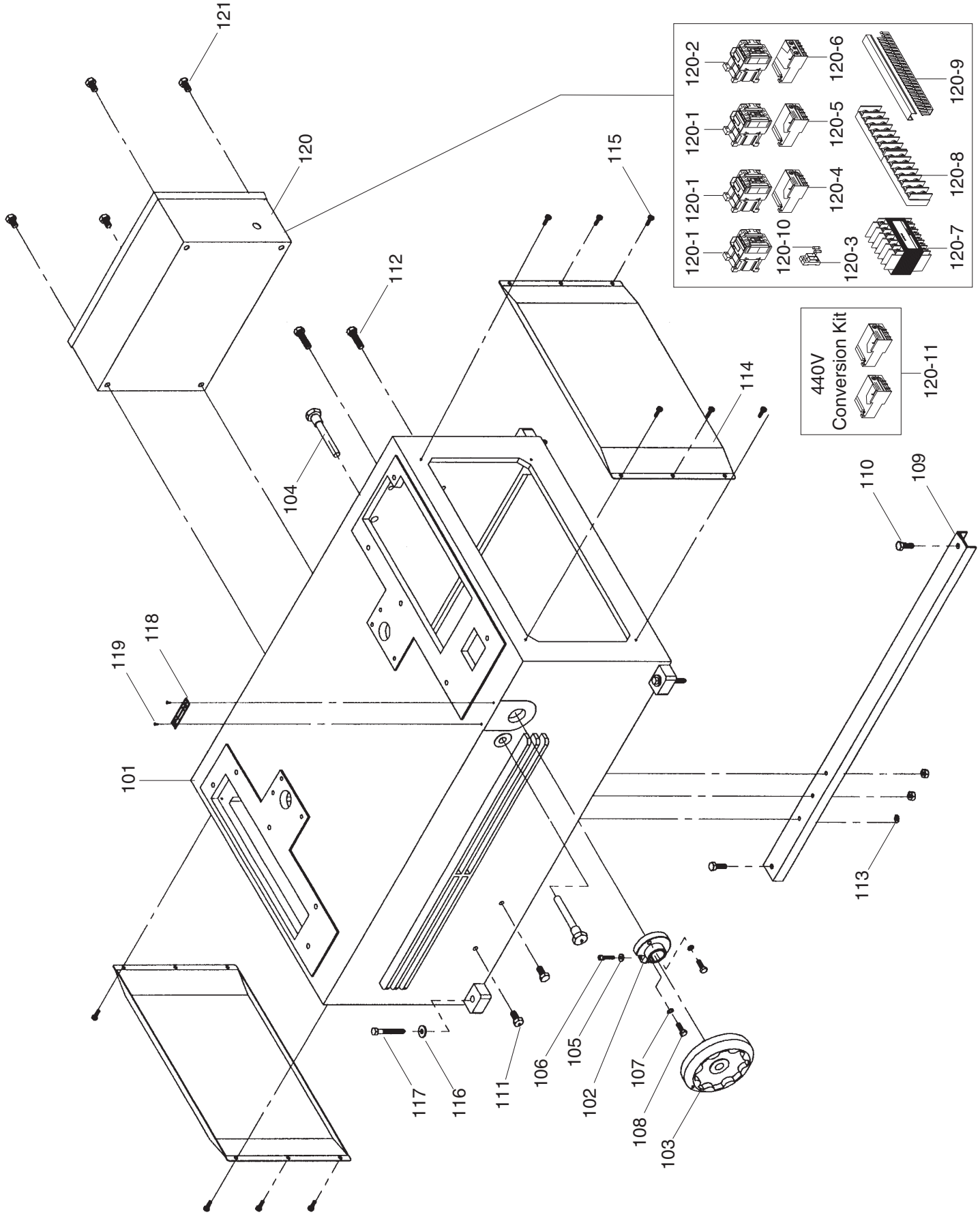

G9740/G9740Z/G9967/G9967Z/G9741/G9961

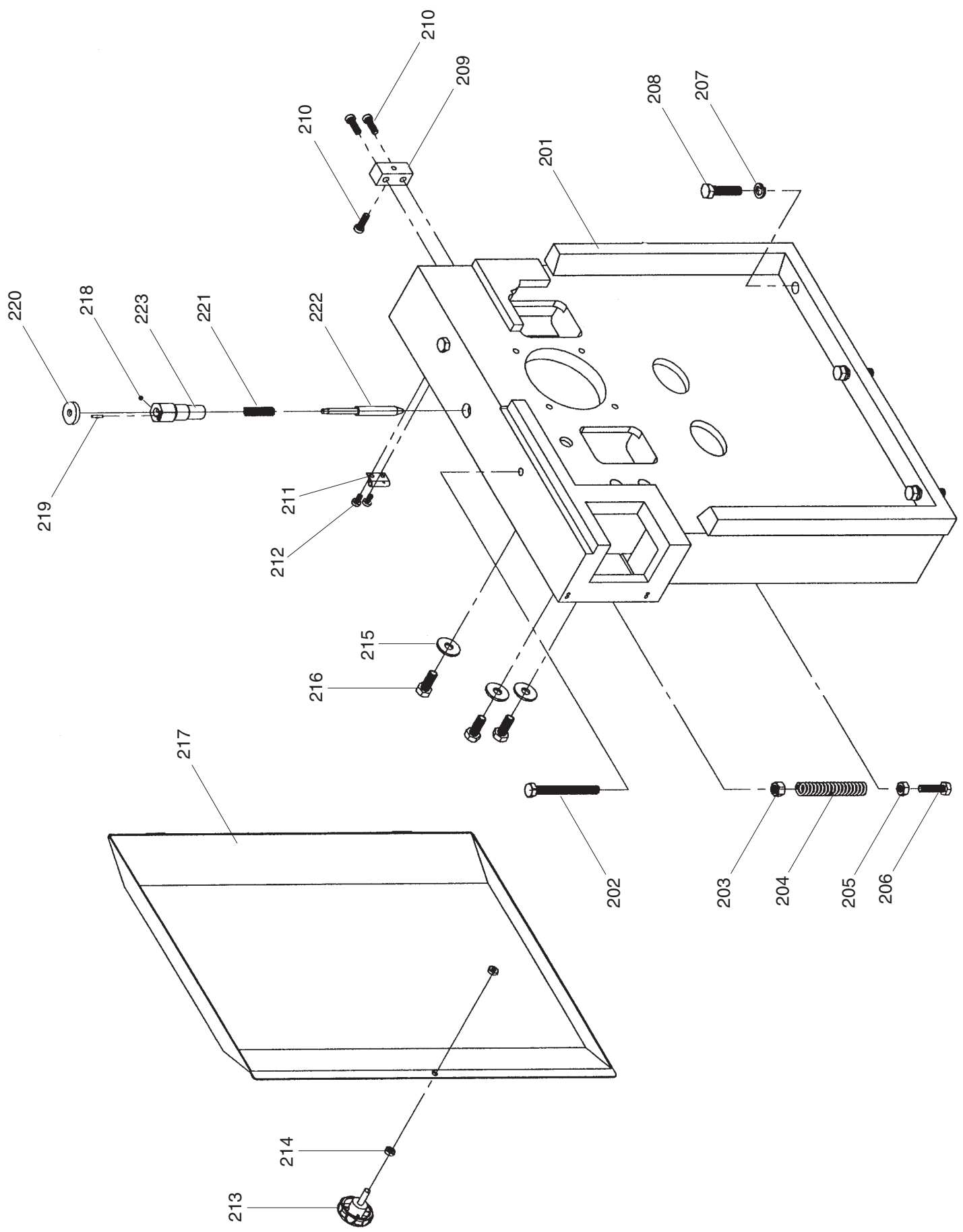

G9740/G9740Z/G9967/G9967Z/G9741/G9961

REF	PART #	DESCRIPTION
101	P97400101	CABINET (20")
101	P97410101	CABINET (24")
102	P97400102	SPEED CHANGE NUT
103	P97400103	HANDWHEEL
104	P97400104	SLIP BOLT
105	PW06	FLAT WASHER 1/4
106	PSB62	CAP SCREW 1/4-20 X 1 1/2
107	PLW04M	LOCK WASHER 8MM
108	PB07M	HEX BOLT M8-1.25 X 25
109	P97400109	MOTOR MOUNT (20")
109	P97410109	MOTOR MOUNT (24")
110	PB01M	HEX BOLT M10-1.5 X 30
111	PB25M	HEX BOLT M12-1.75 X 25
112	PB24M	HEX BOLT M12-1.75 X 45
113	PN02M	HEX NUT M10-1.5
114	P97400114	CABINET DOOR
115	PS26M	PHLP HD SCR M6-1 X 20
116	PW02	FLAT WASHER 3/8
117	PB60	HEX BOLT 3/8-16 X 3
118	P97400118	SPEED CHANGE LABEL
119	P97400119	RIVET
120	P97400120	ELECTRIC BOX
120-1	P97400120-1	CN-11 CONTACTOR
120-2	P97400120-2	CN-18 CONTACTOR (7.5HP)
120-2	P99670120-2	CN-25 CONTACTOR (5/10HP)
120-3	P97400120-3	FUSE BOX
120-4	P97400120-4	RHN-18/2.5A RELAY (ELV 3Ø)
120-4	P99670120-4	RHN-18/4A RELAY (ELV 1Ø)
120-5	P97400120-5	RHN-18/6A RELAY (FEED 3Ø)
120-5	P99670120-5	RHN-18/9A RELAY (FEED 1Ø)
120-6	P97400120-6	EOCR-SP RELAY (7.5HP)

REF	PART #	DESCRIPTION
120-6	P99670120-6	EOCR-SS RELAY (5/10HP)
120-7	P97400120-7	TRANSFORMER
120-8	P97400120-8	TERMINAL STRIP 26 CIRCUIT
120-9	P97400120-9	WIRING DUCT W/COVER
120-10	P97400120-10	FUSE 3 AMP
120-11	P97400120-11	440V CONVERSION KIT (RELAYS RH-18 1.7-2.5/1-1.7)
121	PB49M	HEX BOLT M12-1.75 X 20
201	P97400201	LEFT WALL
202	PB76M	HEX BOLT M12-1.75 X 110
203	PN09M	HEX NUT M12-1.75
204	P97400204	HELICAL ROLLER SPRING
205	PN02M	HEX NUT M10-1.5
206	PB31M	HEX BOLT M10-1.5 X 40
207	PLW05M	LOCK WASHER 12MM
208	PB33M	HEX BOLT M12-1.75 X 50
209	P97400209	COVER SUPPORT
210	PSB31M	CAP SCREW M8-1.25 X 25
211	P97400211	CATCH PLATE
212	PS65M	PHLP HD SCR M6-1 X 10
213	P97400213	KNOB BOLT M10-1.5 X 20
214	PN03M	HEX NUT M8-1.25
215	PW06M	FLAT WASHER 12MM
216	PB27M	HEX BOLT M12-1.75 X 30
217	P97400217	LEFT WALL DOOR
218	PSS02M	SET SCREW M6-1 X 6
219	PRP64M	ROLL PIN 3 X 18
220	P97400220	HANDLE
221	P97400221	HELICAL PULLEY SPRING
222	P97400222	BRAKE ROD
223	P97400223	BRAKE CASING

G9740/G9740Z/G9967/G9967Z/G9741/G9961

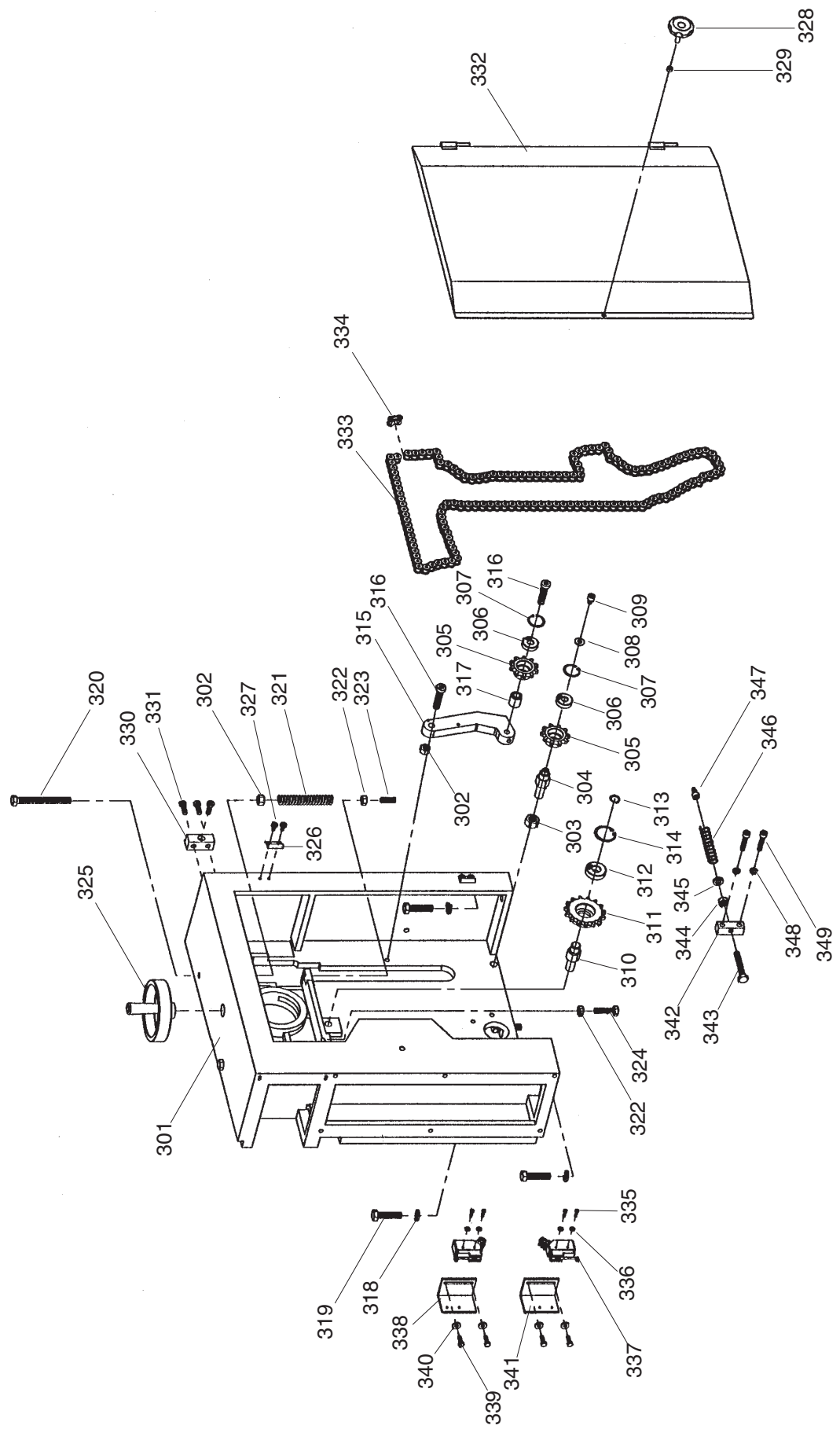

G9740/G9740Z/G9967/G9967Z/G9741/G9961

REF	PART #	DESCRIPTION
301	P97400301	RIGHT WALL
302	PN09M	HEX NUT M12-1.75
303	PN04	HEX NUT 5/8-11
304	P97400304	SPROCKET SHAFT
305	P97400305	SPROCKET
306	P6201	BALL BEARING 6201
307	PR29M	INT RETAINING RING 32MM
308	P97400308	SPECIAL WASHER 8MM
309	PSB52M	CAP SCREW M8-1.25 X 10
310	P97400310	SPROCKET SHAFT
311	P97400311	SPROCKET
312	P6203	BALL BEARING 6203
313	P97400313	EXT RETAINING RING 17MM
314	PR23M	INT RETAINING RING 40MM
315	P97400315	SPROCKET PLATE
316	PSB73M	CAP SCREW M12-1.75 X 50
317	P97400317	BEARING WASHER
318	PLW07	LOCK WASHER 1/2
319	PB33M	HEX BOLT M12-1.75 X 50
320	PB76M	HEX BOLT M12-1.75 X 110
321	P97400321	HELICAL ROLLER SPRING
322	PN02M	HEX NUT M10-1.5
323	PSS73M	SET SCREW M10-1.5 X 30
324	PB31M	HEX BOLT M10-1.5 X 40
325	P97400325	HANDWHEEL

REF	PART #	DESCRIPTION
326	P97400326	CATCH PLATE
327	PS65M	PHLP HD SCR M6-1 X 10
328	P97400328	KNOB BOLT M10-1.5 X 20
329	PN02M	HEX NUT M8-1.25
330	P97400330	COVER SUPPORT
331	PSB31M	CAP SCREW M8-1.25 X 25
332	P97400332	RIGHT WALL DOOR
333	P97400333	CHAIN 5/8
334	P97400334	CHAIN CONNECTOR LINK 5/8
335	PS17M	PHLP HD SCR M4-.7 X 6
336	PW05M	FLAT WASHER 4MM
337	P97400337	LIMIT SWITCH
338	P97400338	UPPER LIMIT SWITCH PLATE
339	PB08M	HEX BOLT M6-1 X 20
340	PW06	FLAT WASHER 1/4
341	P97400341	LOWER LIMIT SWITCH PLATE
342	P97400342	SEAT
343	PB31M	HEX BOLT M10-1.5 X 40
344	PN02M	HEX NUT M10-1.5
345	PW04M	FLAT WASHER 10MM
346	P97400346	HELICAL SPRING
347	P97400347	CAP SCREW M8-1.25 X 6
348	PLW04M	LOCK WASHER 8MM
349	PSB12M	CAP SCREW M8-1.25 X 40

G9740/G9740Z/G9967/G9967Z/G9741/G9961

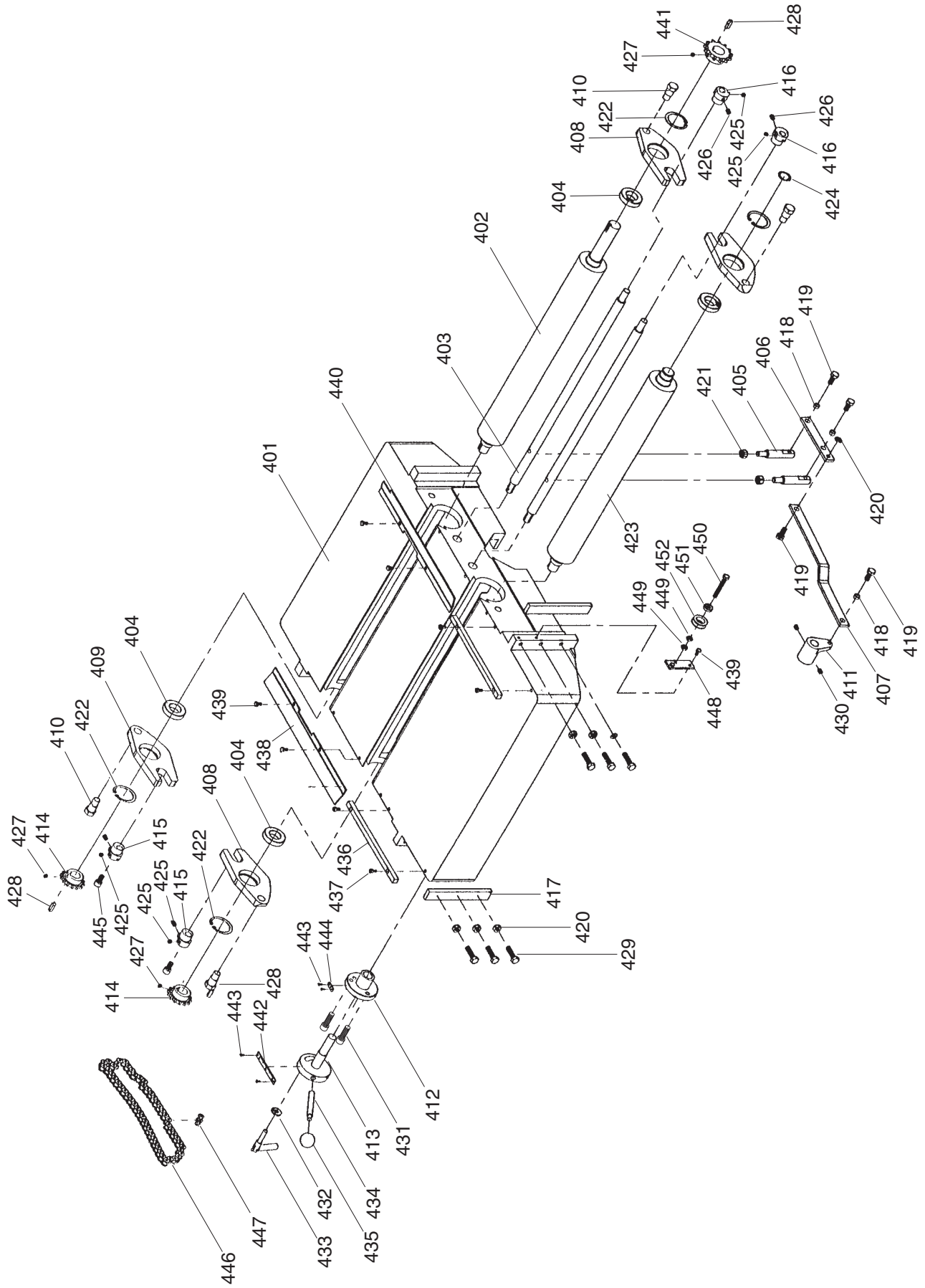

G9740/G9740Z/G9967/G9967Z/G9741/G9961

REF	PART #	DESCRIPTION
401	P97400401	TABLE (20")
401	P97410401	TABLE (24")
402	P97400402	TABLE ROLLER (20")
402	P97410402	TABLE ROLLER (24")
403	P97400403	ECCENTRIC SHAFT (20")
403	P97410403	ECCENTRIC SHAFT (24")
404	P6006	BALL BEARING 6006
405	P97400405	ECCENTRIC PULL ROD
406	P97400406	SHORT ROLLER ADJ BAR
407	P97400407	LONG ROLLER ADJ BAR
408	P97400408	ROLR BEARING HOUSING (R)
409	P97400409	ROLR BEARING HOUSING (L)
410	P97400410	HOUSING PIVOT BOLT
411	P97400411	ACCOLADE SEAT
412	P97400412	ADAMANT SEAT
413	P97400413	ADJUSTMENT SEAT
414	P97400414	CLOSED SPROCKET 14T
415	P97400415	ROLLER ECCENTRIC (L)
416	P97400416	ROLLER ECCENTRIC (R)
417	P97400417	GIB (20")
417	P97410417	GIB (24")
418	P97400418	SPACER RING
419	PB32M	HEX BOLT M10-1.5 X 25
420	PN02M	HEX NUT M10-1.5
421	PN09M	HEX NUT M12-1.75
422	PR51M	INT RETAINING RING 55MM
423	P97400423	SHORT ROLLER (20")
423	P97410423	SHORT ROLLER (24")
424	PR15M	EXT RETAINING RING 30MM

REF	PART #	DESCRIPTION
425	PSB69	CAP SCREW 5/16-18 X 1/4
426	PSS08	SET SCREW 5/16-18 X 1/2
427	PSS17M	SET SCREW M8-1.25 X 6
428	PK27M	KEY 7 X 7 X 25
429	PB31M	HEX BOLT M10-1.5 X 40
430	PSB52M	CAP SCREW M8-1.25 X 10
431	PSB11M	CAP SCREW M8-1.25 X 16
432	PW02	FLAT WASHER 3/8
433	P97400433	MOVABLE BOLT 3/8
434	P97400434	ADJUSTMENT HANDLE STUD
435	P97400435	ROUND KNOB (FEMALE) 3/8
436	P97400436	DOUBLE-SIDED IRON BAR
437	PSB26M	CAP SCREW M6-1 X 12
438	P97400438	LEFT PROTECTION PLATE
439	PB02M	HEX BOLT M6-1 X 12
440	P97400440	RIGHT PROTECTION PLATE
441	P97400441	TABLE ROLLER SPROCKET
442	P97400442	HANDLE SCALE MARK
443	P97400443	RIVET
444	P97400444	GRADUATED SCALE
445	PSB61M	CAP SCREW M10-1.5 X 20
446	P97400446	CHAIN 1/2
447	P97400447	CHAIN 1/2 MASTER LINK
448	P97400448	TABLE PULLEY PLATE
449	PN03M	HEX NUT M8-1.25
450	PSB66M	CAP SCREW M8-1.25 X 65
451	P608ZZ	BALL BEARING 608ZZ
452	P97400452	PULLEY L

G9740/G9740Z/G9967/G9967Z/G9741/G9961

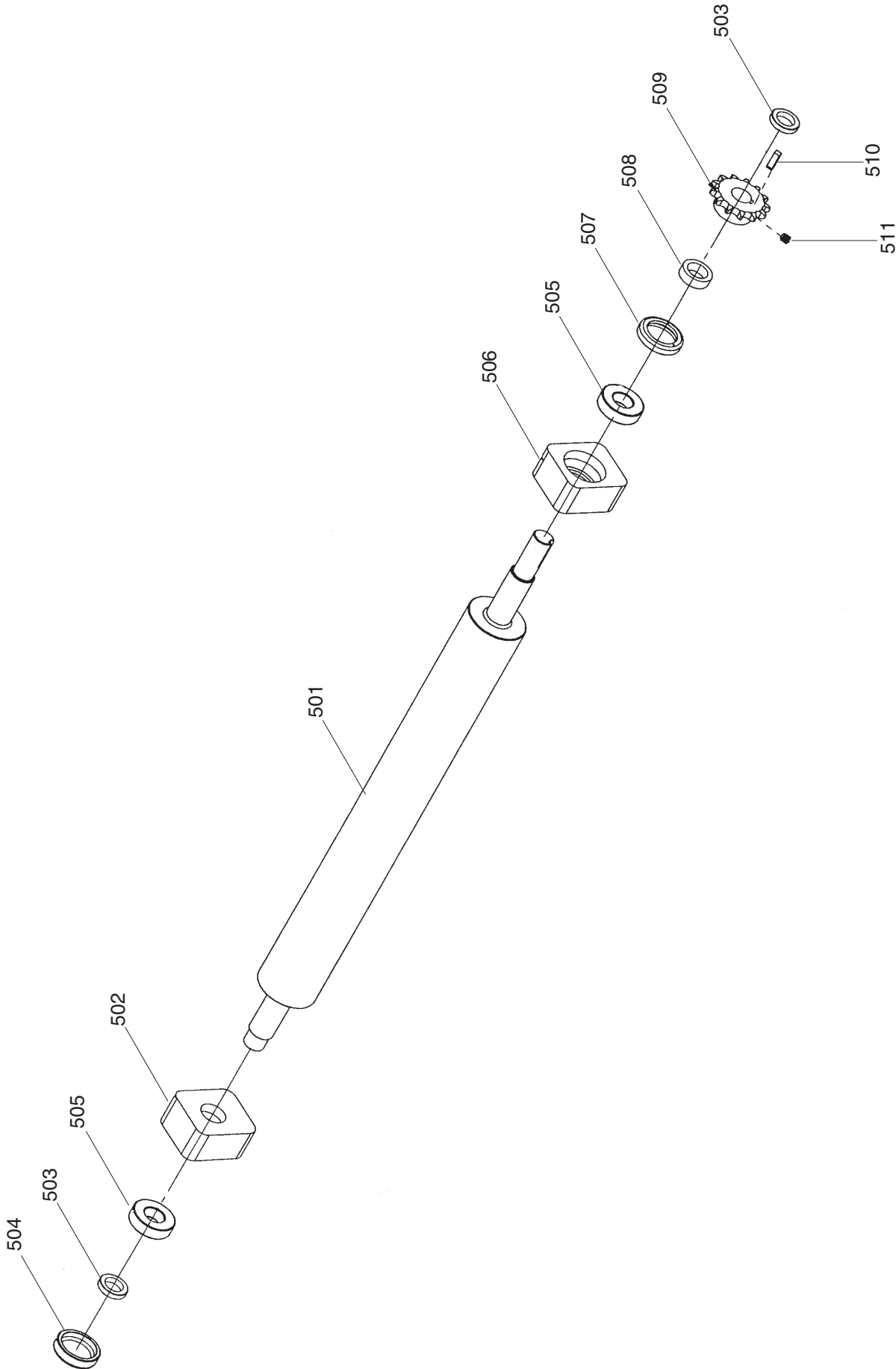

G9740/G9740Z/G9967/G9967Z/G9741/G9961

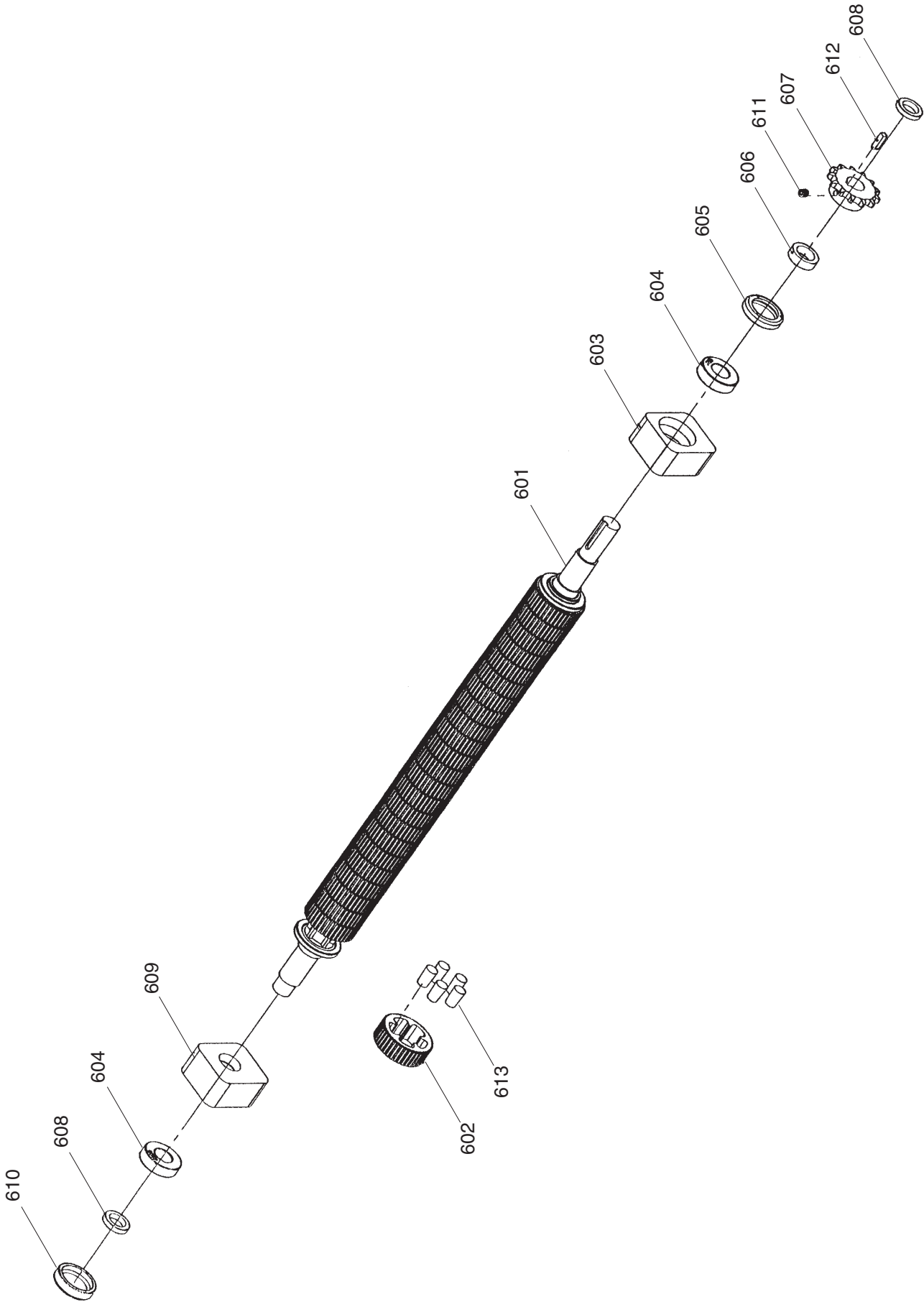

G9740/G9740Z/G9967/G9967Z/G9741/G9961

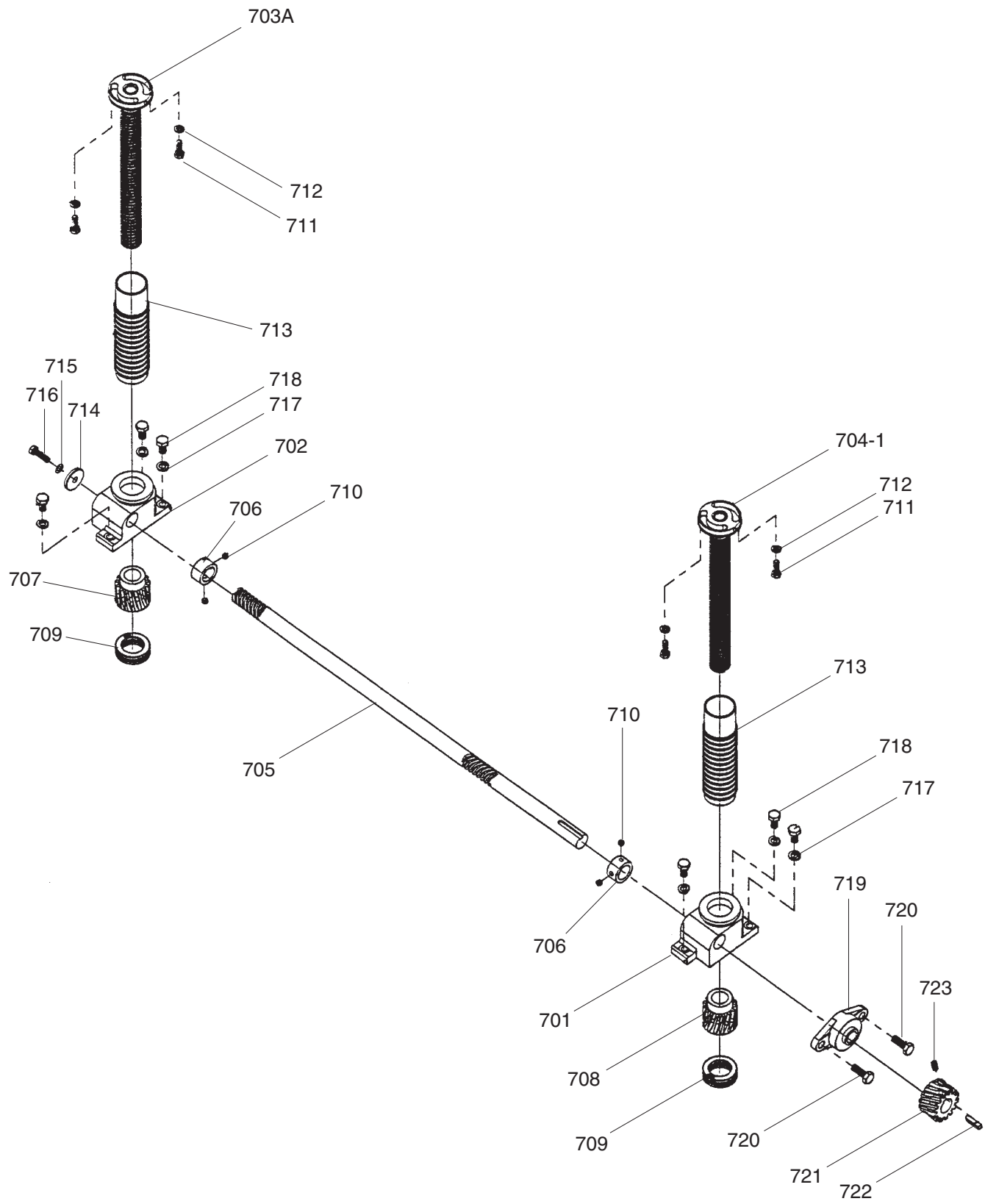

G9740/G9740Z/G9967/G9967Z/G9741/G9961

REF	PART #	DESCRIPTION
501	P97400501	OUTFEED ROLLER (20")
501	P97410501	OUTFEED ROLLER (24")
502	P97400502	LEFT BEARING BLOCK (RT)
503	P97400503	FIXED BEARING NUT
504	P97400504	LEFT CASE COVER
505	P6205	BALL BEARING 6205
506	P97400506	RIGHT BEARING BLOCK (LT)
507	P97400507	RIGHT CASE COVER
508	P97400508	SPROCKET WASHER
509	P97400509	FEED ROLLER SPROCKET
510	PK27M	KEY 7 X 7 X 25
511	PSS15	SET SCREW 38-16 X 38
601	P97400601	INFEED ROLLER (20")
601	P97410601	INFEED ROLLER (24")
602	P97400602	COLLAR
603	P97400603	RIGHT ROLLER CASE (LT)
604	P6205	BALL BEARING 6205
605	P97400605	RIGHT CASE COVER
606	P97400606	SPROCKET WASHER
607	P97400607	FEED ROLLER SPROCKET
608	P97400608	BEARING FIXED NUT
609	P97400609	LEFT ROLLER CASE (RT)
610	P97400610	LEFT CASE COVER
611	PSS15	SET SCREW 38-16 X 38
612	PK27M	KEY 7 X 7 X 25

REF	PART #	DESCRIPTION
613	P97400613	CIRCULAR RUBBER
701	P97400701	LIFTING GEAR SEAT (R)
702	P97400702	LIFTING GEAR SEAT (L)
703A	P97400703	LIFTING GEAR ASSY LEFT
704-1	P97400704	RIGHT LIFT SCR 1-1/4 X 400 W/GEAR
705	P97400705	WORM GEAR (20")
705	P97410705	WORM GEAR (24")
706	P97400706	FIXED STOP COLLAR
707	P97400707	LEFT LIFTING GEAR
708	P97400708	RIGHT LIFTING GEAR
709	P2907	BALL BEARING 2907
710	PSS05	SET SCREW 5/6-18 X 1/4
711	PB07M	HEX BOLT M8-1.25 X 25
712	PLW01	LOCK WASHER 5/16
713	P97400713	RUBBER SLEEVE
714	P97400714	FENDER WASHER 3/8
715	PLW04M	LOCK WASHER 8MM
716	PB26M	HEX BOLT M8-1.25 X 30
717	PLW06M	LOCK WASHER 10MM
718	PB74M	HEX BOLT M10-1.5 X 20
719	P6205	BALL BEARING 6205
720	PB01M	HEX BOLT M10-1.5 X 30
721	P97400721	WORM WHEEL
722	PK61M	KEY 7 X 7 X 30
723	PSS06M	SET SCREW M8-1.25 X 16

G9740/G9740Z/G9967/G9967Z/G9741/G9961

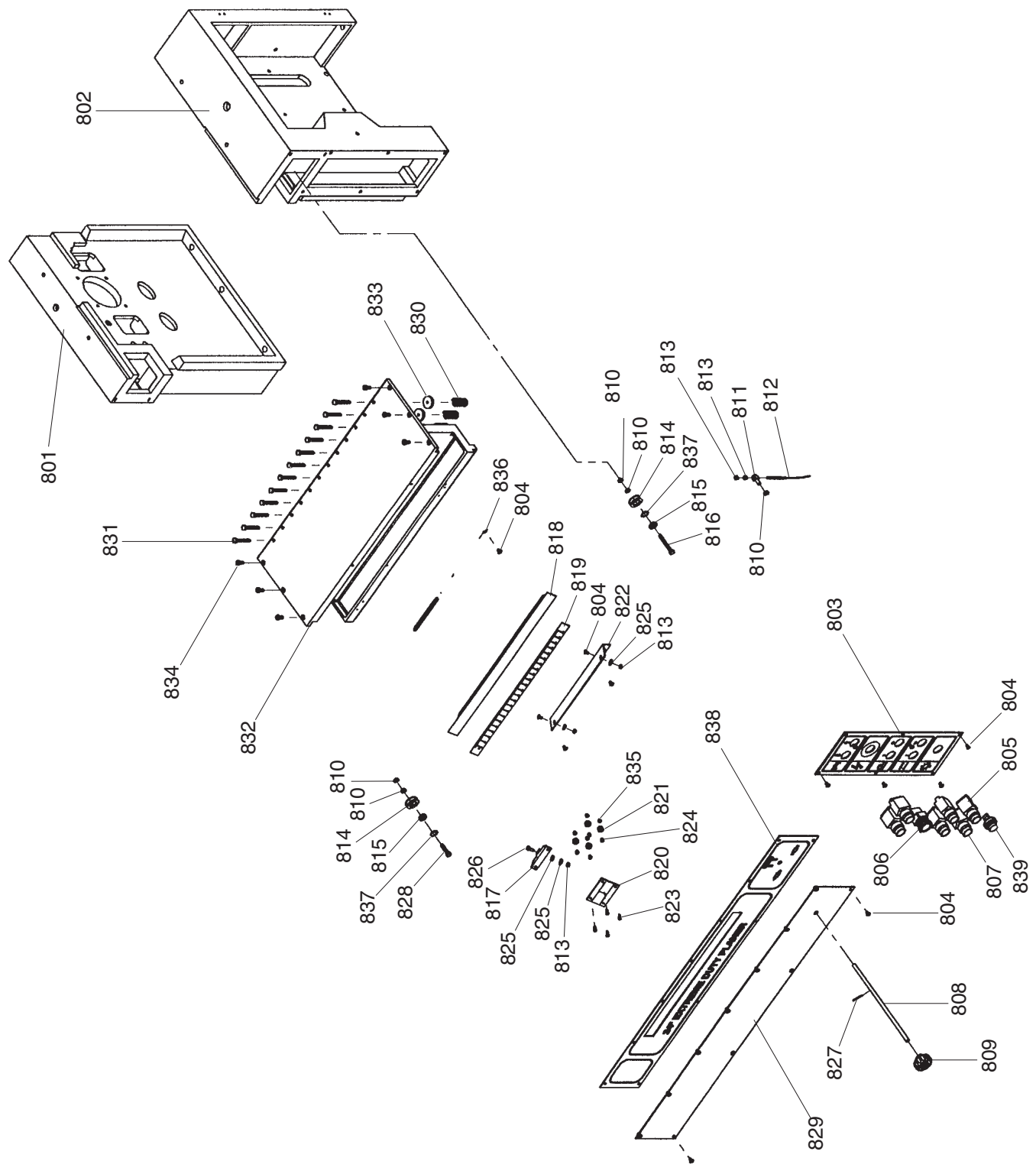

G9740/G9740Z/G9967/G9967Z/G9741/G9961

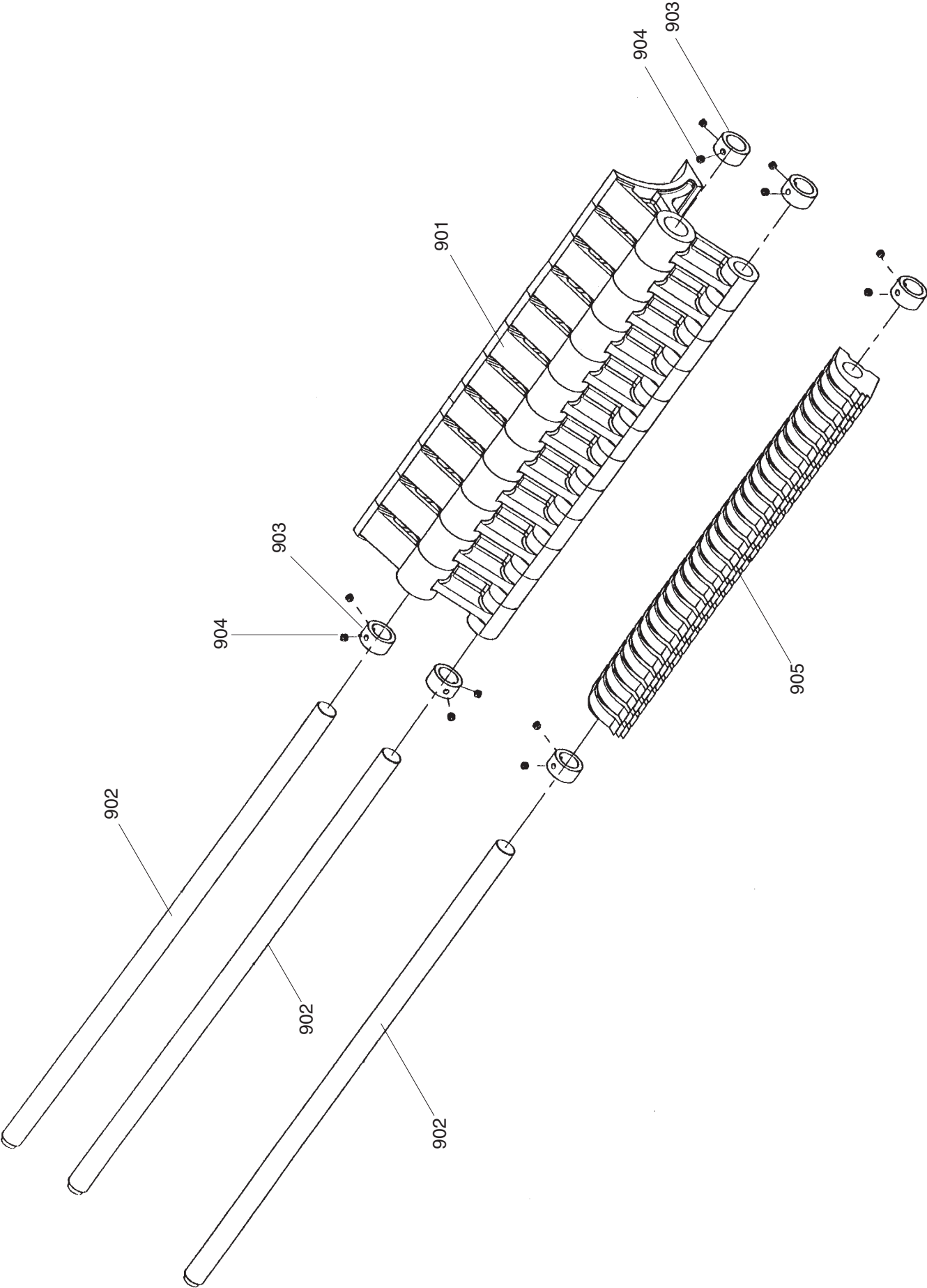

G9740/G9740Z/G9967/G9967Z/G9741/G9961

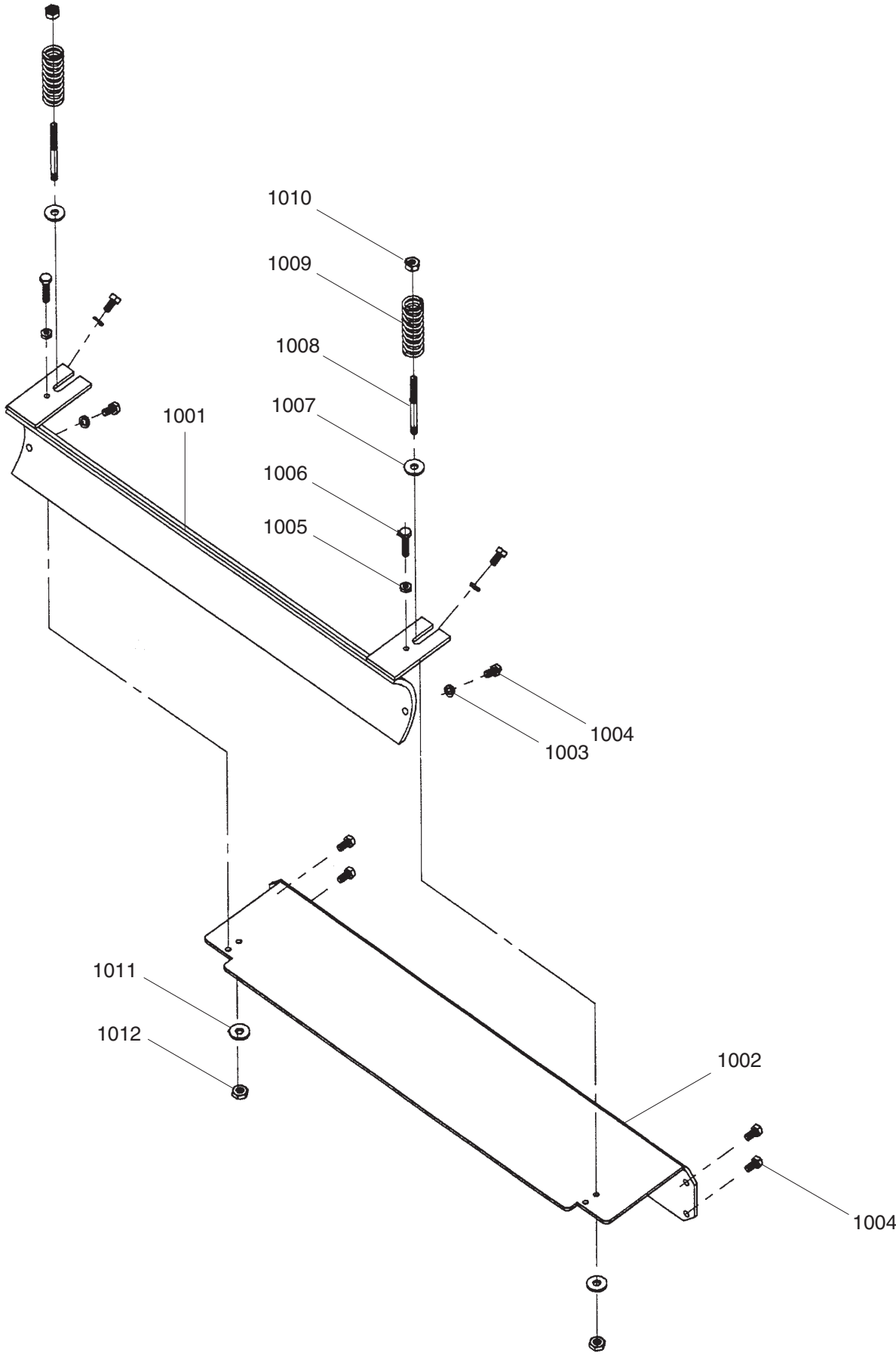

G9740/G9740Z/G9967/G9967Z/G9741/G9961

REF	PART #	DESCRIPTION
801	P97400801	LEFT WALL THIN SHORT
802	P97400802	RIGHT WALL THICK SHORT
803	P97400803	SWITCH PLATE
804	PS65M	PHLP HD SCR M6-1 X 10
805	P97400805	PUSH-BUTTON SWITCH T1
806	P97400806	SWITCH RED
807	P97400807	PUSH-BUTTON SWITCH T2
808	P97400808	ELEVATION LOCK STUD
809	P97400809	KNOB M10 (FEMALE)
810	PN03M	HEX NUT M8-1.25
811	P97400811	GRADUATION STRUT
812	P97400812	SCALE ROPE
813	PN01M	HEX NUT M6-1
814	P97400814	PULLEY (L)
815	P608ZZ	BALL BEARING 608
816	PSB66M	CAP SCREW M8-1.25 X 65
817	P97400817	SCALE PLATE SUPPORT
818	P97400818	SCALE SUPPORT (20")
818	P97410818	SCALE SUPPORT (24")
819	P97400819	GRADUATED SCALE (20")
819	P97410819	GRADUATED SCALE (24")
820	P97400820	MOVABLE SCALE PLATE
821	P97400821	PULLEY (S)
822	P97400822	SCALE SUPPORT (20")
822	P97410822	SCALE SUPPORT (24")
823	PS30	PHLP HD SCR 5/32 X 1
824	P97400824	PULLEY FERRULE (S)
825	PW06	FLAT WASHER 1/4
826	P97400826	SCALE PLATE BOLT
827	P97400827	COTTER PIN 1/16 X 1
828	PB20M	HEX BOLT M8-1.25 X 35
829	P97400829	PROTECTION PLATE (20")
829	P97410829	PROTECTION PLATE (24")

REF	PART #	DESCRIPTION
830	P97400830	COMPRESS PAWL SPRING
831	PSB60M	CAP SCREW M8-1.25 X 55
832	P97400832	FRONT SEAT (20")
832	P97410832	FRONT SEAT (24")
833	P97400833	CLAW SPRING NUT
834	PSB11M	CAP SCREW M8-1.25 X 16
835	PN06M	HEX NUT M5-.8
836	P97400836	SCALE SPRING
837	PW01M	FLAT WASHER 8MM
838	P97400838	SCALE PLATE (20")
838	P97410838	SCALE PLATE (24")
839	P97400839	POWER LIGHT
901	P97400901	PAWL
902	P97400902	STOP PAWL SHAFT (20")
902	P97410902	STOP PAWL SHAFT (24")
903	P97400903	STOP PAWL FIXED RING
904	PSS17M	SET SCREW M8-1.25 X 6
905	P97400905	STOP PAWL
1001	P97401001	PRESSURE BAR (20")
1001	P97411001	PRESSURE BAR (24")
1002	P97401002	PROTECTION PLATE (20")
1002	P97411002	PROTECTION PLATE (24")
1003	PLW01	LOCK WASHER 5/16
1004	PB03M	HEX BOLT M8-1.25 X 16
1005	PN03M	HEX NUT M8-1.25
1006	PB20M	HEX BOLT M8-1.25 X 35
1007	PW02	FLAT WASHER 3/8
1008	P97401008	PISTON BOLT
1009	P97401009	HELICAL SPRING 80MM L
1010	PN08	HEX NUT 3/8-16
1011	PW02	FLAT WASHER 3/8
1012	PN08	HEX NUT 3/8-16

G9740/G9740Z/G9967/G9967Z/G9741/G9961

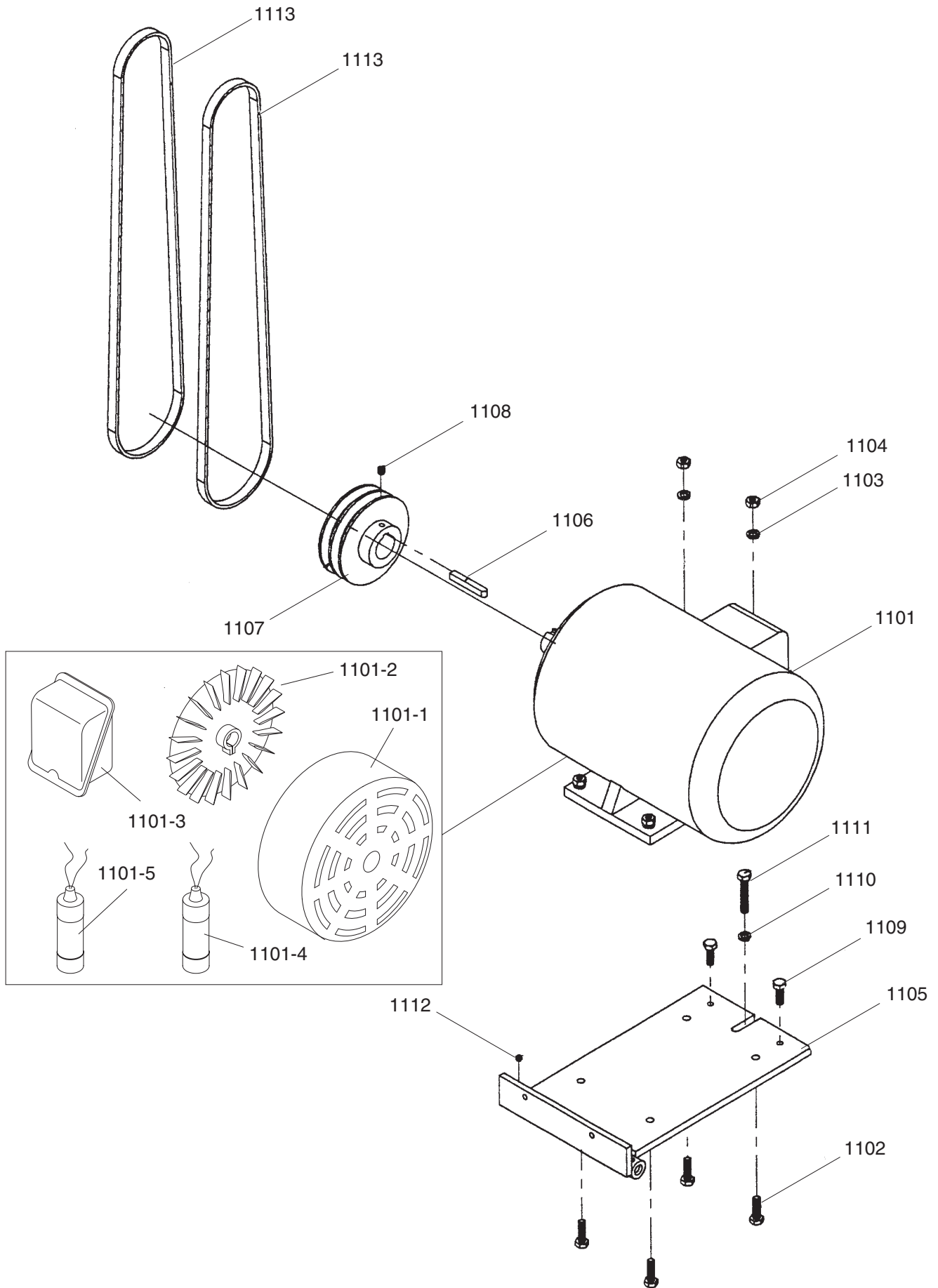

G9740/G9740Z/G9967/G9967Z/G9741/G9961

1101	P97401101	G9740/Z MOTOR 7.5HP,3Ø
1101	P99671101	G9967/Z MOTOR 5HP, 1Ø
1101	P97411101	G9741/61 MOTOR 10HP, 3Ø
1101-1	P97401101-1	G9740/Z MOTOR COVER
1101-1	P99671101-1	G9967/Z MOTOR COVER
1101-1	P97411101-1	G9741/61 MOTOR COVER
1101-2	P97401101-2	G9740/Z MOTOR FAN
1101-2	P99671101-2	G9967/Z MOTOR FAN
1101-2	P97411101-2	G9741/61 MOTOR FAN
1101-3	P97401101-3	G9740/Z WIRING BOX
1101-3	P99671101-3	G9967/Z WIRING BOX
1101-3	P97411101-3	G9741/61 WIRING BOX
1101-4	P99671101-4	G9967/Z START CAPACITOR 250VAC, 800MFD
1101-5	P99671101-5	G9967/Z RUN CAPACITOR 350VAC, 30MFD
1102	PB14M	HEX BOLT M10-1.5 X 35
1103	PLW06M	LOCK WASHER 10MM
1104	PN02M	HEX NUT M10-1.5
1105	P97401105	MOTOR PLATE
1106	PK78M	KEY 10 X 10 X 70
1107	P97401107	MOTOR PULLEY (2P, SMALL)
1108	PSS15	SET SCREW 3/8-16 X 3/8
1109	PB01M	HEX BOLT M10-1.5 X 30
1110	PLW04	LOCK WASHER 3/8

1111	P97401111	HEX BOLT M10-1.5 X 60
1112	PSS17M	SET SCREW M8-1.25 X 6
1113	PVB71	V-BELT B71
1201	P97401201	FEED MOTOR 1HP, 3Ø
1201	P99671201	FEED MOTOR 1HP, 1Ø
1201-1	P97401201-1	FEED MOTOR COVER, 3Ø
1201-1	P99671201-1	FEED MOTOR COVER, 1Ø
1201-2	P97401201-2	FEED MOTOR FAN, 3Ø
1201-2	P99671201-2	FEED MOTOR FAN, 1Ø
1201-3	P97401201-3	FD MTR WIRING BOX, 3Ø
1201-3	P99671201-3	FD MTR WIRING BOX, 1Ø
1201-4	P99671201-4	FEED MOTOR CAPACITOR 250VAC, 25MFD
1201-5	P99671201-5	FD MTR CAPACITOR COVER
1202	P97401202	MOTOR SLIP SQUARE (20")
1202	P97411202	MOTOR SLIP SQUARE (24")
1203	PB01M	HEX BOLT M10-1.5 X 30
1204	PLW06M	LOCK WASHER 10MM
1205	PN02M	HEX NUT M10-1.5
1206	P97401206	SPEED CHANGE ROD
1207	PB18	HEX BOLT 3/8-16 X 1
1208	PK07M	KEY 6 X 6 X 20
1209	P97401209	SPEED CHANGE PULLEY
1210	P97401210	V-BELT 20X10X1085MM (3Ø)
1210	P99671210	V-BELT 14X22X420MM (1Ø)

G9740/G9740Z/G9967/G9967Z/G9741/G9961

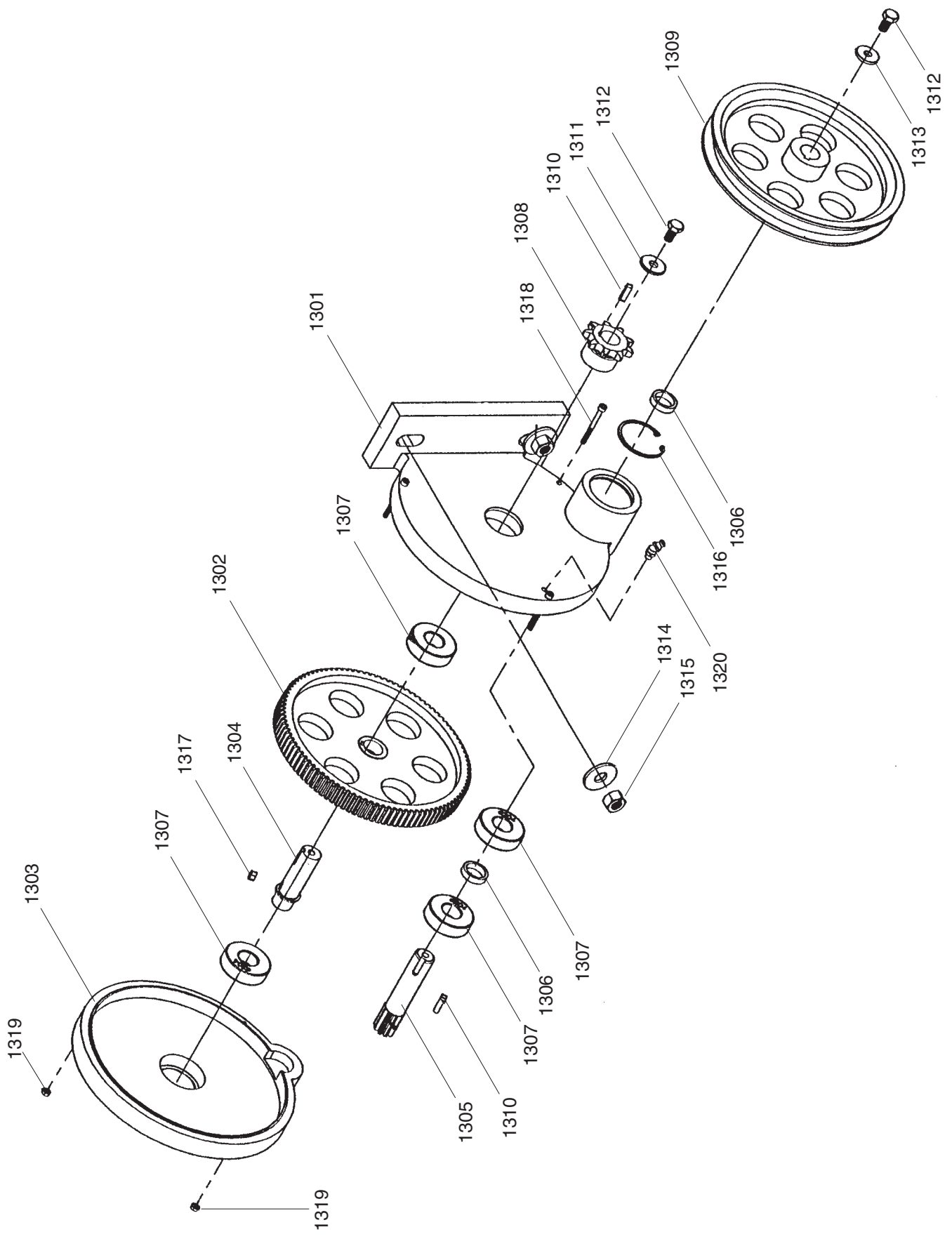

G9740/G9740Z/G9967/G9967Z/G9741/G9961

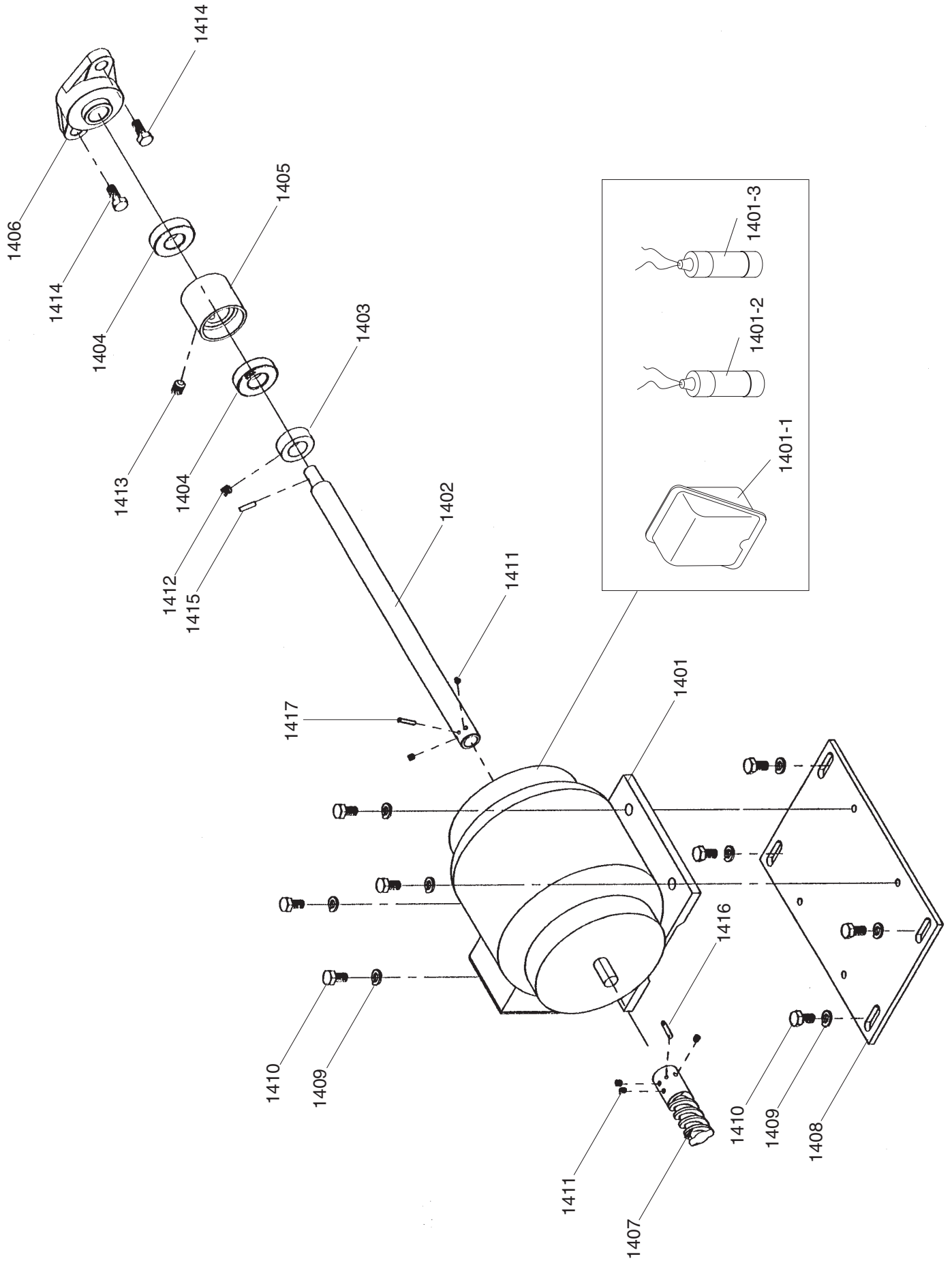

G9740/G9740Z/G9967/G9967Z/G9741/G9961

1301	P97401301	TRANSMISSION BOX
1302	P97401302	TRANSMISSION BOX GEAR
1303	P97401303	TRANSMISSION BOX CAP
1304	P97401304	TRANSMISSION SHAFT
1305	P97401305	GEAR SHAFT
1306	P97401306	BEARING SPACER
1307	P6204	BALL BEARING 6204
1308	P97401308	TRANSMISSION SPROCKET
1309	P97401309	TRANNNY PULLEY 8" (3Ø)
1309	P99671309	TRANNNY PULLEY 10" (1Ø)
1310	PK34M	KEY 5 X 5 X 20
1311	PW02	FLAT WASHER 3/8
1312	PB03M	HEX BOLT M8-1.25 X 16
1313	PW07	FLAT WASHER 5/16
1314	PW01	FLAT WASHER 1/2
1315	PN09M	HEX NUT M12-1.75
1316	PR25M	INT RETAINING RING 47MM
1317	PK06M	KEY 5 X 5 X 10
1318	PB77M	HEX BOLT M4-.7 X 45
1319	PN04M	HEX NUT M4-.7
1320	PZERK3	GREASE FITTING 1/8
1401	P97401401	ELEV MOTOR 1/2HP, 3Ø
1401	P99671401	ELEV MOTOR 1/2HP, 1Ø

1401-1	P97401401-1	EL MTR WIRING BOX, 3Ø
1401-1	P99671401-1	EL MTR WIRING BOX, 1Ø
1401-2	P99671401-2	ELEV START CAPACITOR 125VAC, 200MFD
1401-3	P99671401-3	ELEV RUN CAPACITOR 250VAC, 20MFD
1402	P97401402	SHORT ELEVATION ROD
1403	P97401403	ELEVATION COLLAR
1404	P6004	BALL BEARING 6004
1405	P97401405	BEARING HOUSING
1406	P97401406	BEARING UCFL 204-20
1407	P97401407	LIFTING MOTOR WORM
1408	P97401408	LIFTING MOTOR PLATE
1409	PLW01	LOCK WASHER 5/16
1410	PB03M	HEX BOLT M8-1.25 X 16
1411	PSS13M	SET SCREW M10-1.5 X 12
1412	PSS20M	SET SCREW M8-1.25 X 8
1413	PSS13M	SET SCREW M10-1.5 X 12
1414	PB09M	HEX BOLT M8-1.25 X 20
1415	PRP60M	ROLL PIN 4 X 15
1416	PRP56M	ROLL PIN 4 X 25
1417	PRP39M	ROLL PIN 4 X 20

G9740/G9740Z/G9967/G9967Z/G9741/G9961

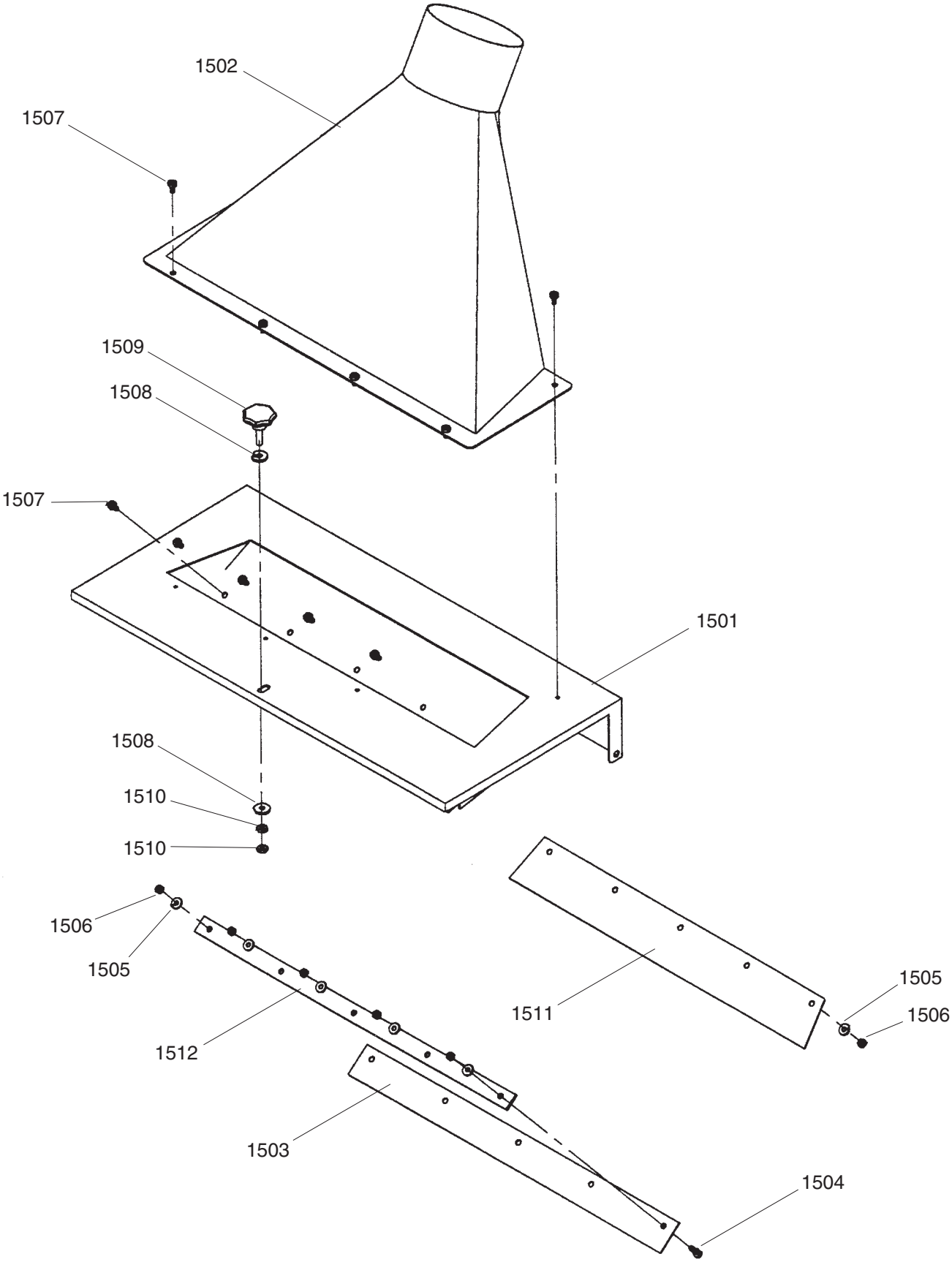

G9740Z/G9967Z/G9961 Spiral Cutterhead

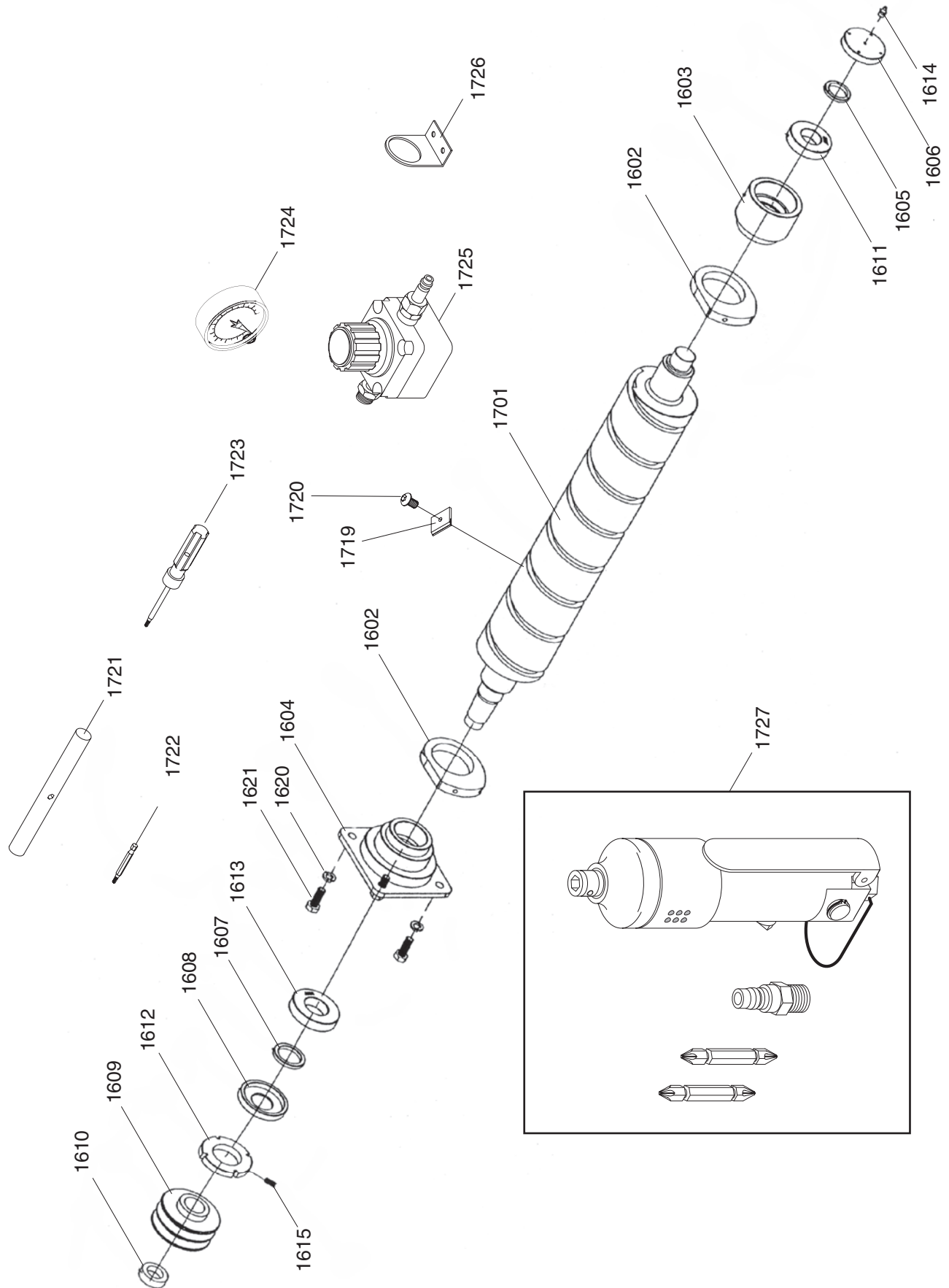

G9740/G9740Z/G9967/G9967Z/G9741/G9961

REF	PART #	DESCRIPTION
1501	P97401501	DISCHARGE COVER (20")
1501	P97411501	DISCHARGE COVER (24")
1502	P97401502	DUST PORT (20")
1502	P97411502	DUST PORT (24")
1503	P97401503	RUBBER SEAL (20")
1503	P97411503	RUBBER SEAL (24")
1504	PS26M	PHLP HD SCR M6-1 X 20
1505	PW06	FLAT WASHER 1/4
1506	PN01M	HEX NUT M6-1
1507	PS65M	PHLP HD SCR M6-1 X 10
1508	PW07	FLAT WASHER 5/16
1509	P97401509	KNOB BOLT M8-1.25 X 30
1510	PN03M	HEX NUT M8-1.25
1511	P97401511	MUFFLE PLATE (20")
1511	P97411511	MUFFLE PLATE (24")
1512	P97401512	RUBBER SEAL PLATE (20")
1512	P97411512	RUBBER SEAL PLATE (24")
1601	P97401601	CUTTERHEAD (20")
1601	P97411601	CUTTERHEAD (24")
1602	P97401602	PISTON RING
1603	P97401603	SMALL CUTTERHEAD CASE
1604	P97401604	LARGE CUTTERHEAD CASE
1605	P97401605	SMALL BEARING RING
1606	P97401606	SMALL CASE COVER
1607	P97401607	LARGE CASE
1608	P97401608	LARGE CASE COVER

REF	PART #	DESCRIPTION
1609	P97401609	CUTTERHEAD PULLEY
1610	P97401610	CUTTERHEAD PULLY NUT
1611	P6207	BALL BEARING 6207
1612	P97401612	CUTTERHEAD STOP PLATE
1613	P6208	BALL BEARING 6208
1614	PZERK3	GREASE FITTING 1/8
1615	PSS18	SET SCREW 5/16-18 X 3/4
1616	P97401616	COMPRESSION SPRING
1617	H2340	KNIFE SET OF 4 (20")
1617	H2342	KNIFE SET OF 4 (24")
1618	P97401618	GIB (20")
1618	P97411618	GIB (24")
1619	P97401619	GIB BOLTS
1620	PLW05M	LOCK WASHER 12MM
1621	PB75M	HEX BOLT M12-1.75 X 35
1701	P9740Z1701	SPIRAL FLAT CUTTERHEAD
1701	P99611701	SPIRAL FLAT CUTTERHEAD
1719	H2334	INDEXABLE CUTTERS
1720	PFH35M	FLAT HD TORX T-20 M6 X 15
1721	P9740Z1721	CHEATER BAR FOR T-20 BIT
1722	P9740Z1722	T-20 TORX BIT
1723	P9740Z1723	T-20 TORX DRIVER
1724	P9740Z1724	PRESSURE GAUGE FOR KIT
1725	P9740Z1725	REDUCING VALVE FOR KIT
1726	P9740Z1726	L-BRACKET
1727	P9740Z1727	AIR SCREWDRIVER KIT