

READ THIS FIRST



Model G7214Z

IMPORTANT UPDATE

For Machines Mfd. Since 12/24
and Owner's Manual Revised 03/19

For questions or help with this product contact Tech Support at (570) 546-9663 or techsupport@grizzly.com

The following change was recently made since the owner's manual was printed:

- Part change.

Aside from this information, all other content in the owner's manual applies and MUST be read and understood for your own safety. **IMPORTANT: Keep this update with the owner's manual for future reference.**

For questions or help, contact our Tech Support at (570) 546-9663 or techsupport@grizzly.com.

Revised Part

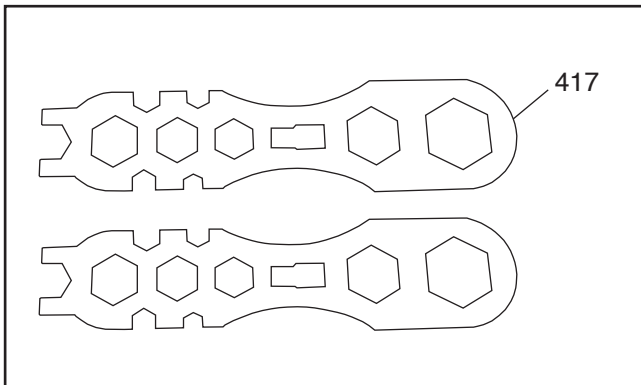

Revised Inventory

Model G7214Z Inventory

Qty

- Multi-Wrenches 10, 12, 13, 14, 19, 21, 23, 26, 30, 38mm 2

REF	PART #	DESCRIPTION
417	P7214Z417	MULTI-WRENCH

COPYRIGHT © NOVEMBER, 2024 BY GRIZZLY INDUSTRIAL, INC.
WARNING: NO PORTION OF THIS MANUAL MAY BE REPRODUCED IN ANY SHAPE OR FORM WITHOUT THE WRITTEN APPROVAL OF GRIZZLY INDUSTRIAL, INC.
 #LW23322 PRINTED IN TAIWAN

READ THIS FIRST



Model G5912Z/G7214Z/G8621

*****IMPORTANT UPDATE*****

For Machines Mfd. Since 1/17
and Owner's Manual Printed 2001

For questions or help with this product contact Tech Support at (570) 546-9663 or techsupport@grizzly.com

The following changes were recently made to this machine since the owner's manual was printed:

- Added an additional spindle enclosure guard.
- Changed spindle cartridge support fasteners.

Aside from this information, all other content in the owner's manual applies and **MUST** be read and understood for your own safety. **IMPORTANT: Keep this update with the owner's manual for future reference.**

For questions or help, contact our Tech Support at (570) 546-9663 or techsupport@grizzly.com.

New Parts

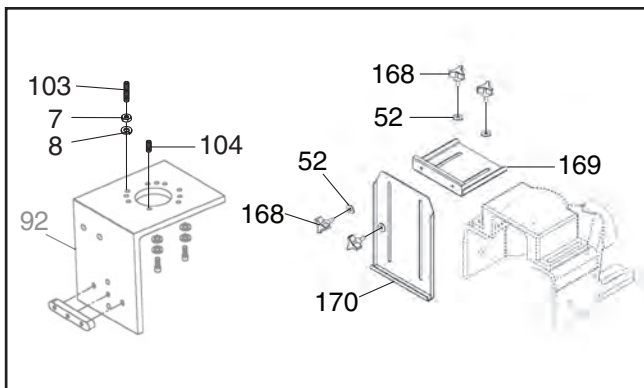

REF	PART #	DESCRIPTION
7	P5912Z007	HEX NUT 3/8-16
8	P5912Z008	LOCK WASHER 3/8
52	P5912Z052	FLAT WASHER 1/4
103	P5912Z103	SET SCREW 3/8-16 X 1
104	P5912Z104	SET SCREW 3/8-16 X 1/2
168	P5912Z168	KNOB BOLT 1/4-20 X 1/2
169	P5912Z169	FRONT GUARD EXTENSION PLATE
170	P5912Z170	FRONT SPINDLE ENCLOSURE GUARD

New Inventory

Inventory	Qty
A. Front Spindle Enclosure Guard.....	1
B. Front Guard Extension Plate.....	1
C. V-Belt A28 (G8621).....	1
D. Knob Bolts 1/4"-20 x 1/2".....	4
E. Flat Washers 1/4".....	4
F. Knob Bolts 3/8"-16 x 1" (G5912Z, G7214Z). 2	
F. Knob Bolts 3/8"-16 x 1" (G8621).....	4

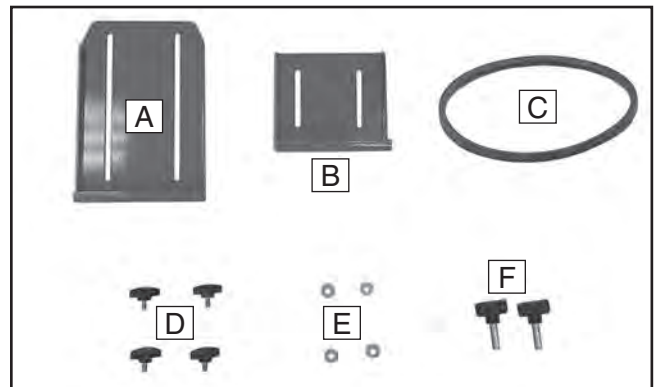

COPYRIGHT © MARCH, 2017 BY GRIZZLY INDUSTRIAL, INC.
WARNING: NO PORTION OF THIS MANUAL MAY BE REPRODUCED IN ANY SHAPE OR FORM WITHOUT THE WRITTEN APPROVAL OF GRIZZLY INDUSTRIAL, INC.
 #BL18759 PRINTED IN TAIWAN

Attaching Spindle Enclosure Guard

Before attaching the spindle enclosure guard, follow instructions in the Owner's Manual for installing the cutter guard and attaching the safety guard (for **G5912Z/G7214Z**, see **Pages 18–19**; for **G8621**, see **Pages 14–15**).

To attach spindle enclosure guard:

1. Attach front guard extension plate to threaded holes on front of safety guard with (2) $\frac{1}{4}$ "-20 x $\frac{1}{2}$ " knob bolts and (2) $\frac{1}{4}$ " flat washers (see **Figure 1**).
2. Attach front spindle enclosure guard to extension plate with (2) $\frac{1}{4}$ "-20 x $\frac{1}{2}$ " knob bolts and (2) $\frac{1}{4}$ " flat washers, (see **Figure 1**).

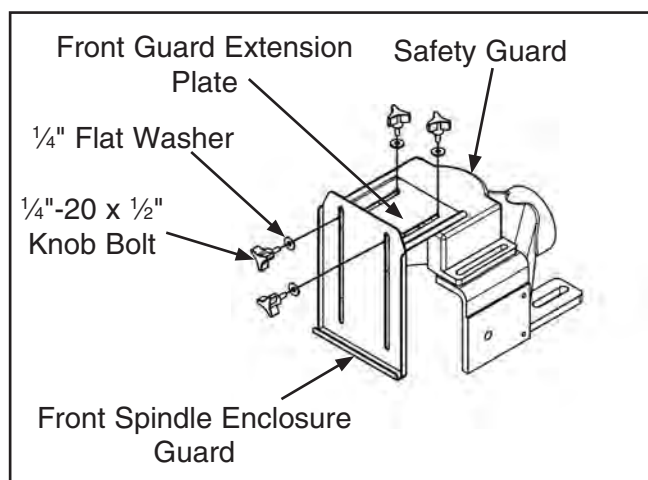
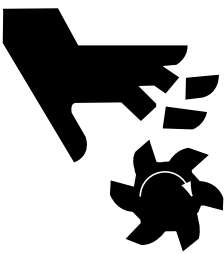

Figure 1. Front guard extension plate and spindle enclosure guard attached to safety guard.

Spindle Enclosure Guard Positioning

The spindle enclosure guard protects the user from exposure to the cutter and chips thrown by it. To minimize the risk of injury, the spindle enclosure guard must be adjusted so it encloses as much of the spindle area as possible, while still allowing the workpiece to pass through the cut. Typically this means the front guard is positioned to just clear the top of the workpiece.

To position the spindle enclosure guard, loosen the top knob bolts and slide the extension plate in or out, then loosen the front knob bolts and raise or lower the spindle enclosure guard as needed. Tighten the knob bolts to secure the setting.

	<p>! WARNING</p> <p>All guards MUST be installed on your shaper before operating it. Shapers can quickly cause serious injury if some kind of guard is not used. To reduce your risk of injury, read and follow the entire Owner's Manual carefully and do additional research on shop made guards and safety jigs.</p>
---	---



Cabinet

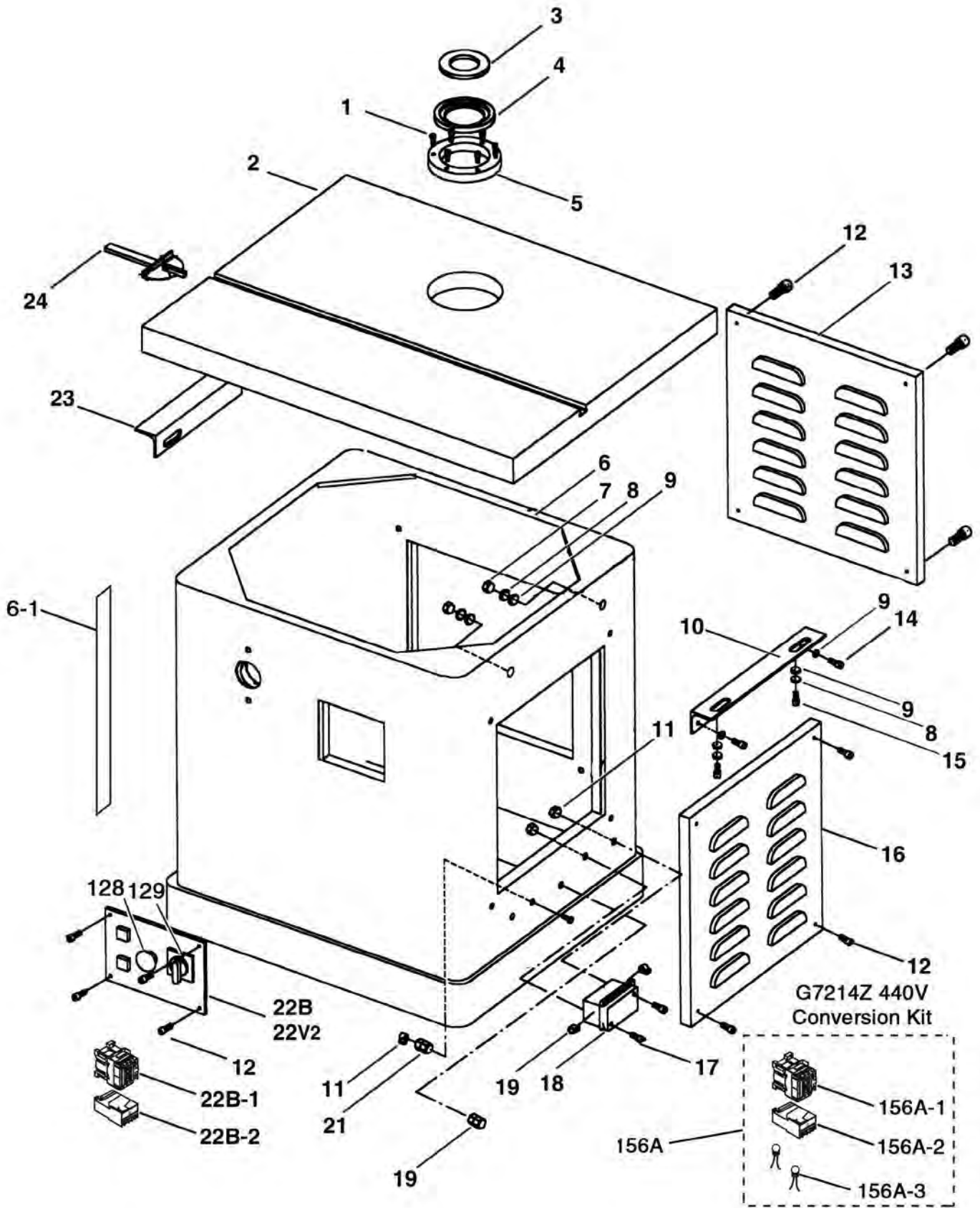

Cabinet Parts List

REF	PART #	DESCRIPTION
1	P5912Z001	SET SCREW 5/16-18 X 5/8
2	P5912Z002	TABLE
3	P5912Z003	INSERT (SMALL) INNER
4	P5912Z004	INSERT (MID)
5	P5912Z005	INSERT (BIG)
6	P5912Z006	STAND ASSY
6-1	P5912Z006-1	DEGREE SCALE
7	P5912Z007	HEX NUT 3/8-16
8	P5912Z008	LOCK WASHER 3/8
9	P5912Z009	FLAT WASHER 3/8
10	P5912Z010	TABLE BRACE (R)
11	P5912Z011	HEX NUT 10-24
12	P5912Z012	PHLP HD SCR 1/4-20 X 5/8
13	P5912Z013	REMOVABLE DUST DOOR
14	P5912Z014	HEX BOLT 3/8-16 X 1-1/4
15	P5912Z015	HEX BOLT 3/8-16 X 3/4
16	P5912Z016	MOTOR COVER
17	P5912Z017	PHLP HD SCR 10-24 X 3/4

REF	PART #	DESCRIPTION
18	P5912Z018	TERMINAL BOX ASSY
18A	P5912Z018A	TERMINAL BOX W/O BUSBAR
19	P5912Z019	STRAIN RELIEF M14.5 TYPE-6 ST
21	P5912Z021	STRAIN RELIEF
22B	P5912Z022B	ELECTRICAL BOX ASSY (G5912Z)
22B-1	P5912Z022B-1	CONTACTOR (G5912Z)
22B-1	P7214Z022B-1	CONTACTOR (G7214Z)
22B-2	P5912Z022B-2	OVERLOAD RELAY (G5912Z)
22B-2	P7214Z022B-2	OVERLOAD RELAY (G7214Z)
22V2	P7214Z022V2	SWITCH BOX ASSEMBLY V2.10.09 (G7214Z)
23	P5912Z023	TABLE BRACE (L)
24	P5912Z024	MITER GAUGE
128	P5912Z128	RESET SWITCH
129	P5912Z129	POWER INDICATOR LIGHT ZD-10 RED
156A	P7214Z156A	440V CONVERSION KIT (G7214Z)
156A-1	P7214Z156A-1	440V MAG CONTACTOR (G7214Z)
156A-2	P7214Z156A-2	440V THERMAL PROTECTOR (G7214Z)
156A-3	P7214Z156A-3	440V LIGHT BULB (G7214Z)



Spindle

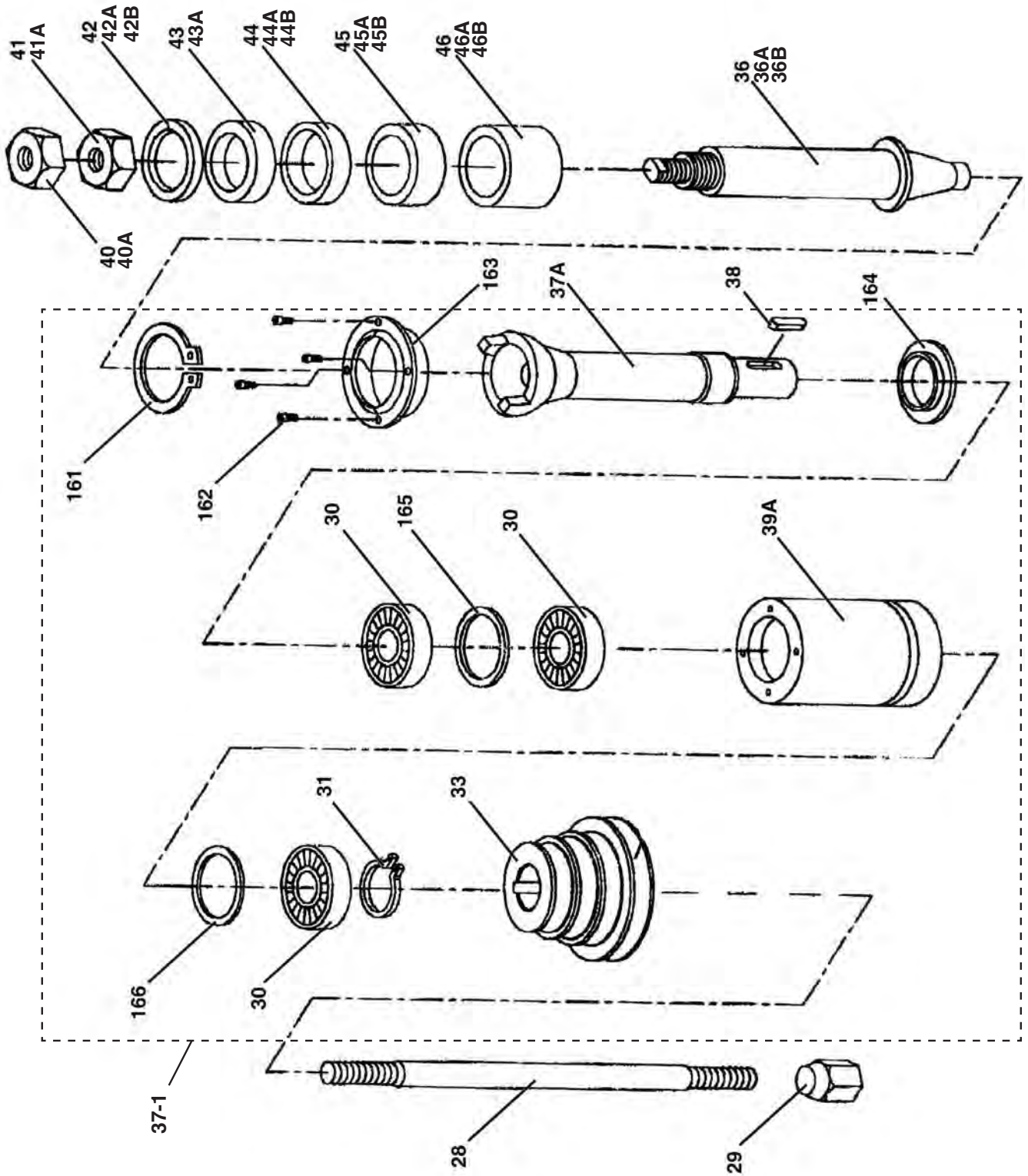

Spindle Parts List

REF	PART #	DESCRIPTION
28	P5912Z028	LOCK BOLT 3/8-11
29	P5912Z029	TAPER LOCK NUT
30	P5912Z030	BALL BEARING 6008ZZ
31	P5912Z031	EXT RETAINING RING 40MM
33	P5912Z033	PULLEY SPINDLE
36	P5912Z036	SPINDLE 1-1/4
36A	P5912Z036A	SPINDLE 3/4"
36B	P5912Z036B	SPINDLE 1"
37-1	P5912Z037-1	PULLEY AND QUILL ASSEMBLY
37A	P5912Z037A	SPINDLE CARTRIDGE ASSY V2.0
38	P5912Z038	KEY 7 X 7 X 40
39A	P5912Z039A	QUILL 7-3/4" LONG V2.01.02
40	P5912Z040	HEX NUT 3/4-16 LH (FOR 1" AND 1-1/4" SPINDLES)
40A	P5912Z040A	HEX NUT 5/8-18 LH (FOR 3/4" SPINDLE)
41	P5912Z041	HEX NUT 1-14 (FOR 1" AND 1-1/4" SPINDLES)
41A	P5912Z041A	HEX NUT 3/4-16 (FOR 3/4" SPINDLE)
42	P5912Z042	COLLAR 1-1/4" X 1/4" (1PC)
42A	P5912Z042A	COLLAR 1" X 1/4"

REF	PART #	DESCRIPTION
42B	P5912Z042B	COLLAR 3/4" X 1/4"
43	P5912Z043	COLLAR 1-1/4" X 3/8" (1PC)
43A	P5912Z043A	COLLAR 1" X 3/8"
44	P5912Z044	COLLAR 1-1/4" X 1/2" (2PC)
44A	P5912Z044A	COLLAR 1" X 1/2"
44B	P5912Z044B	COLLAR 3/4" X 1/2"
45	P5912Z045	COLLAR 1-1/4" X 3/4" (2PC)
45A	P5912Z045A	COLLAR 1" X 3/4" (2PC)
45B	P5912Z045B	COLLAR 3/4" X 3/4" (2PC)
46	P5912Z046	COLLAR 1-1/4" X 1" (2PC)
46A	P5912Z046A	COLLAR 1" X 1" (2PC)
46B	P5912Z046B	COLLAR 3/4" X 1" (2PC)
161	P5912Z161	EXT RETAINING RING 50MM
162	P5912Z162	CAP SCREW M4-.7 X 10
163	P5912Z163	OUTER DUST COVER
164	P5912Z164	INNER DUST COVER
165	P5912Z165	WAVY WASHER
166	P5912Z166	WAVY WASHER



Motor

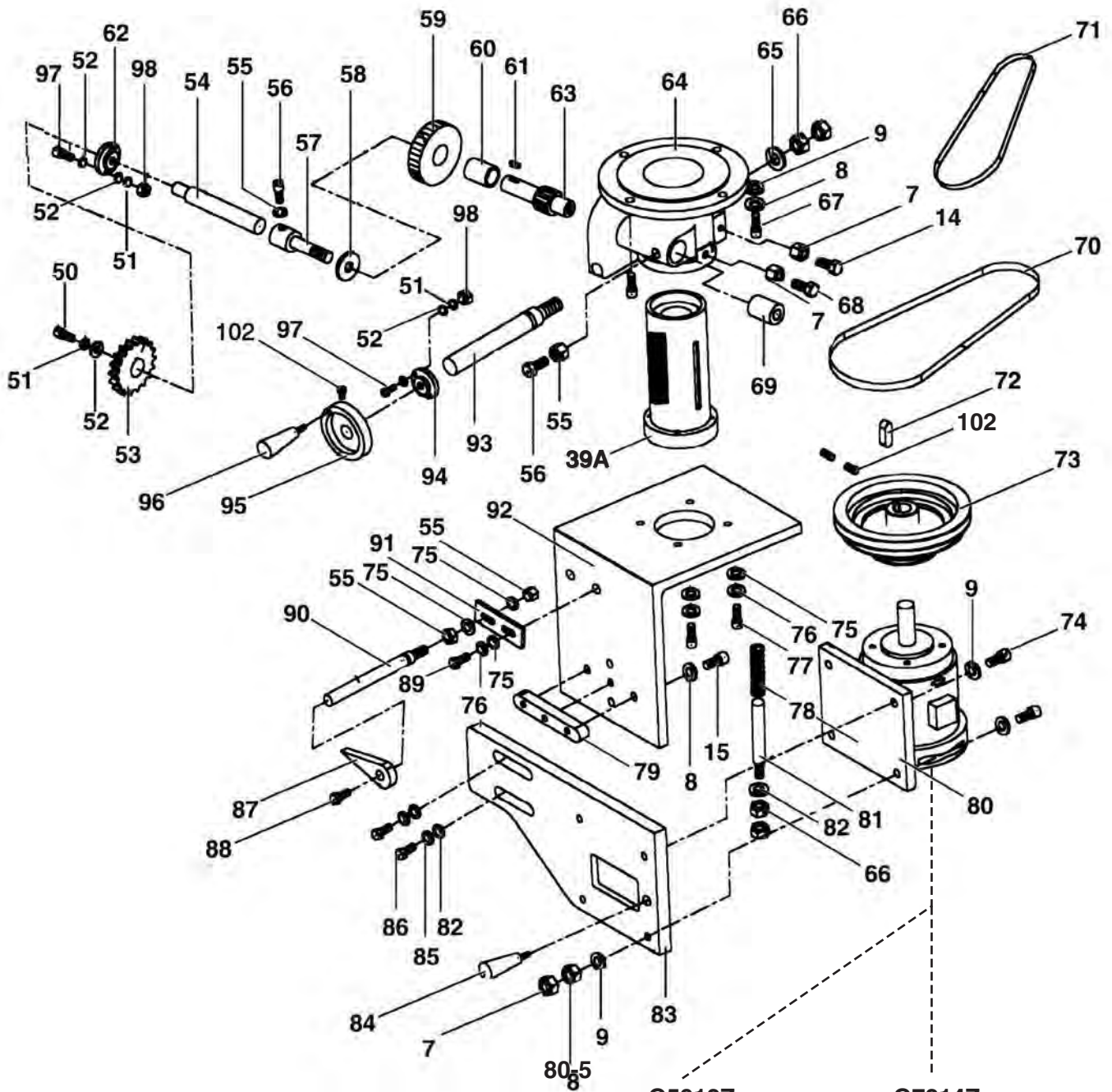

G5912Z

G7214Z

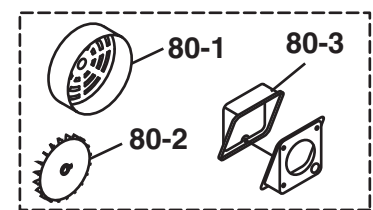
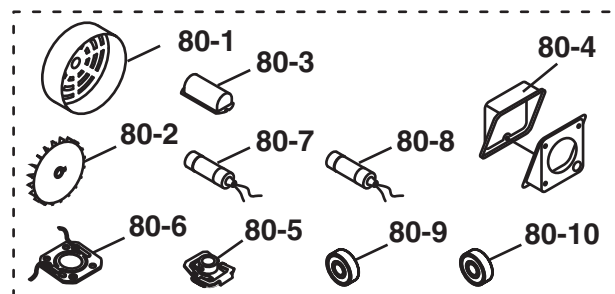

Motor Parts List

REF	PART #	DESCRIPTION
7	P5912Z007	HEX NUT 3/8-16
8	P5912Z008	LOCK WASHER 3/8
9	P5912Z009	FLAT WASHER 3/8
14	P5912Z014	HEX BOLT 3/8-16 X 1-1/4
15	P5912Z015	HEX BOLT 3/8-16 X 3/4
39A	P5912Z039A	QUILL 7-3/4" LONG V2.01.02
50	P5912Z050	HEX BOLT 1/4-20 X 5/8
51	P5912Z051	LOCK WASHER 1/4
52	P5912Z052	FLAT WASHER 1/4
53	P5912Z053	LOCK KNOB
54	P5912Z054	BAR LOCK
55	P5912Z055	HEX NUT 5/16-18
56	P5912Z056	HEX BOLT 5/16-18 X 1
57	P5912Z057	SCREW LOCK
58	P5912Z058	WASHER GEAR
59	P5912Z059	GEAR
60	P5912Z060	COLLAR
61	P5912Z061	KEY 4 X 4 X 16
62	P5912Z062	BASE GEAR SHAFT
63	P5912Z063	SHAFT GEAR
64	P5912Z064	BASE SPINDLE
65	P5912Z065	FLAT WASHER 1/2
66	P5912Z066	LOCK NUT 1/2"-12
67	P5912Z067	CAP SCREW 3/8-16 X 1-1/4
68	P5912Z068	SCREW 3/8-16 X 1-1/4
69	P5912Z069	COLLAR
70	P5912Z070	V-BELT A30
71	P5912Z071	V-BELT A28

REF	PART #	DESCRIPTION
72	P5912Z072	KEY 7 X 7 X 50
73	P5912Z073	MOTOR PULLEY
74	P5912Z074	HEX BOLT 3/8-16 X 1-1/2
75	P5912Z075	FLAT WASHER 5/16
76	P5912Z076	LOCK WASHER 5/16
77	P5912Z077	CAP SCREW 5/16-18 X 1
78	P5912Z078	COMPRESSION SPRING 3.4 X 20.3
79	P5912Z079	KEY 3/8 X 3/4 X 1
81	P5912Z081	SHAFT
82	P5912Z082	FLAT WASHER 1/2
83	P5912Z083	MOTOR BASE
84	P5912Z084	KNOB
85	P5912Z085	LOCK WASHER 1/2
86	P5912Z086	HEX BOLT 1/2-20 X 1
87	P5912Z087	POINTER
88	P5912Z088	PHLP HD SCR 10-24 X 3/8
89	P5912Z089	HEX BOLT 5/16-18 X 3/4
90	P5912Z090	SHAFT GUIDE
91	P5912Z091	PLATE
92	P5912Z092	MOTOR PLATE
93	P5912Z093	SHAFT GEAR
94	P5912Z094	BASE GEAR SHAFT
95	P5912Z095	METAL HANDWHEEL
96	P5912Z096	HANDLE
97	P5912Z097	HEX BOLT 1/4-20 X 1-1/4
98	P5912Z098	HEX NUT 1/4-20
102	P5912Z102	SET SCREW 10-32 X 3/16

G5912Z 5HP, 1-PH MOTOR

80	P5912Z080	MOTOR 5HP 220V 1-PH
80-1	P5912Z080-1	MOTOR FAN COVER
80-2	P5912Z080-2	MOTOR FAN
80-3	P5912Z080-3	CAPACITOR COVER
80-4	P5912Z080-4	MOTOR JUNCTION BOX
80-5	P5912Z080-5	CENT SWITCH 1/2-3450
80-6	P5912Z080-6	CONTACT PLT-TUNGSTEN 5HP
80-7	P5912Z080-7	S CAPACITOR 400M 125V 1-3/4 X 3-3/8
80-8	P5912Z080-8	R CAPACITOR 50M 250V 1-3/4 X 2-3/4
80-9	P5912Z080-9	REAR MOTOR BEARING
80-10	P5912Z080-10	FRONT MOTOR BEARING

G7214Z 7½HP, 3-PH MOTOR

80	P7214Z080	MOTOR 7.5HP 220V 3-PH
80-1	P7214Z080-1	MOTOR FAN COVER
80-2	P7214Z080-2	MOTOR FAN
80-3	P7214Z080-3	MOTOR JUNCTION BOX



Fence Guard

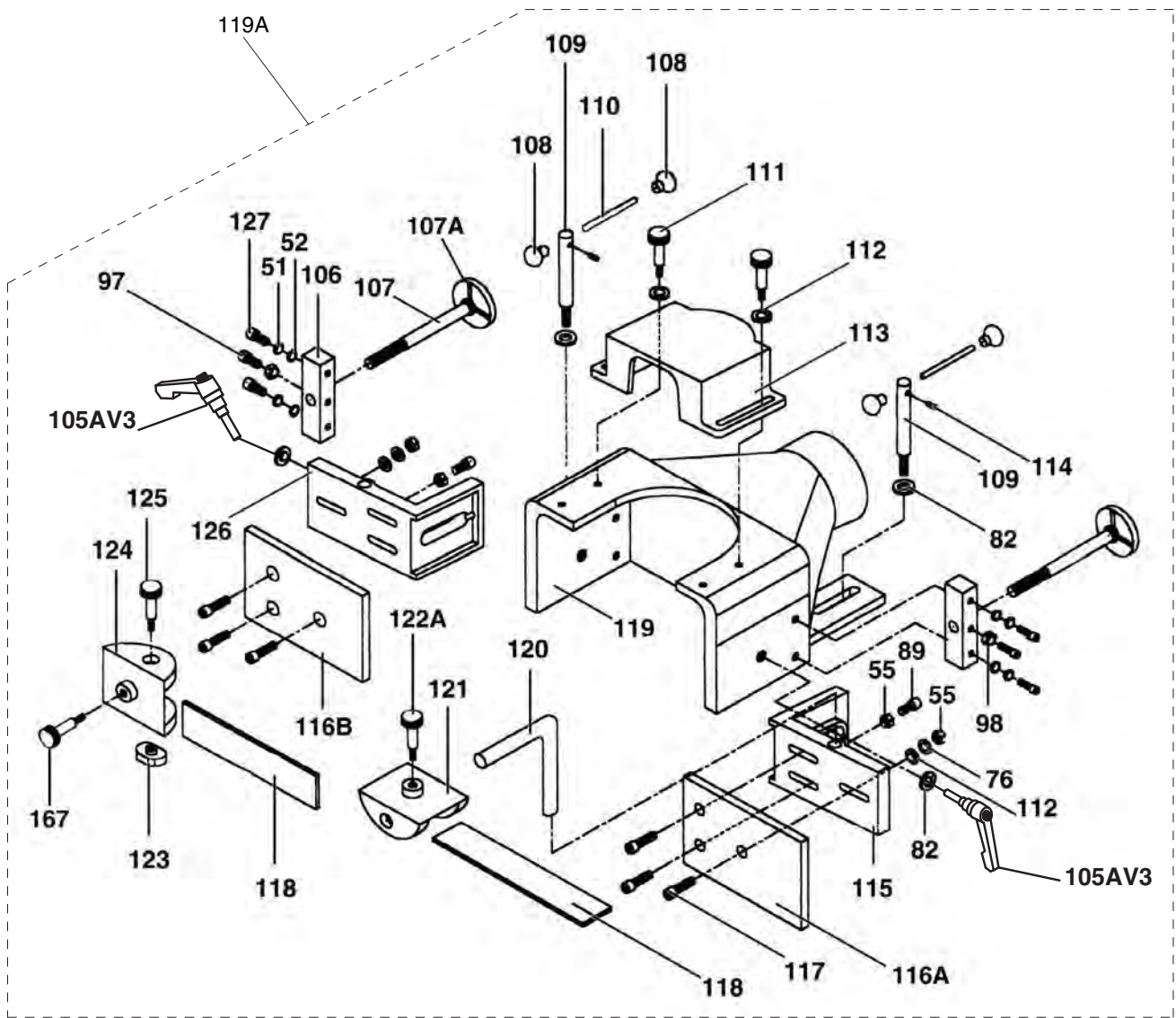

Fence Guard Parts List

REF	PART #	DESCRIPTION
119A	P5912Z119A	COMPLETE FENCE ASSEMBLY
51	P5912Z051	LOCK WASHER 1/4
52	P5912Z052	FLAT WASHER 1/4
55	P5912Z055	HEX NUT 5/16-18
76	P5912Z076	LOCK WASHER 5/16
82	P5912Z082	FLAT WASHER 1/2
89	P5912Z089	HEX BOLT 5/16-18 X 3/4
97	P5912Z097	HEX BOLT 1/4-20 X 1-1/4
98	P5912Z098	HEX NUT 1/4-20
105AV3	P5912Z105AV3	ADJ HANDLE 3"L 1/2-12 X 1-9/16 V3.03.13
106	P5912Z106	BRACKET SCREW GUIDE
107	P5912Z107	SCREW GUIDE ASSY
107A	P5912Z107A	HANDWHEEL
108	P5912Z108	BALL KNOB 3/8-16 (PLASTIC)
109	P5912Z109	SHAFT GUIDE
110	P5912Z110	BAR
111	P5912Z111	KNOB 5/16-18 V1
112	P5912Z112	FLAT WASHER 5/16

REF	PART #	DESCRIPTION
113	P5912Z113	CUTTER GUARD
114	P5912Z114	SET SCREW 1/4-20 X 1/4
115	P5912Z115	BRACKET ASSY FENCE RH
116A	P5912Z116A	WOOD FENCE (RIGHT)
116B	P5912Z116B	WOOD FENCE (LEFT)
117	P5912Z117	FLAT HD SCR 5/16-18 X 1-1/2
118	P5912Z118	HOLD DOWN PLATE
119	P5912Z119	GUARD/DUST HOOD
120	P5912Z120	BAR
121	P5912Z121	RETAINER (L) 5/8"
122A	P5912Z122A	KNOB BOLT 3/8-16 X 1 V2.10.02
123	P5912Z123	NUT 3/8
124	P5912Z124	RETAINER (S) 1/2"
125	P5912Z125	KNOB
126	P5912Z126	BRACKET ASSY FENCE LH
127	P5912Z127	HEX BOLT 1/4-20 X 1-1/2
167	P5912Z167	KNOB BOLT 3/8-16 X 1



Labels & Cosmetics

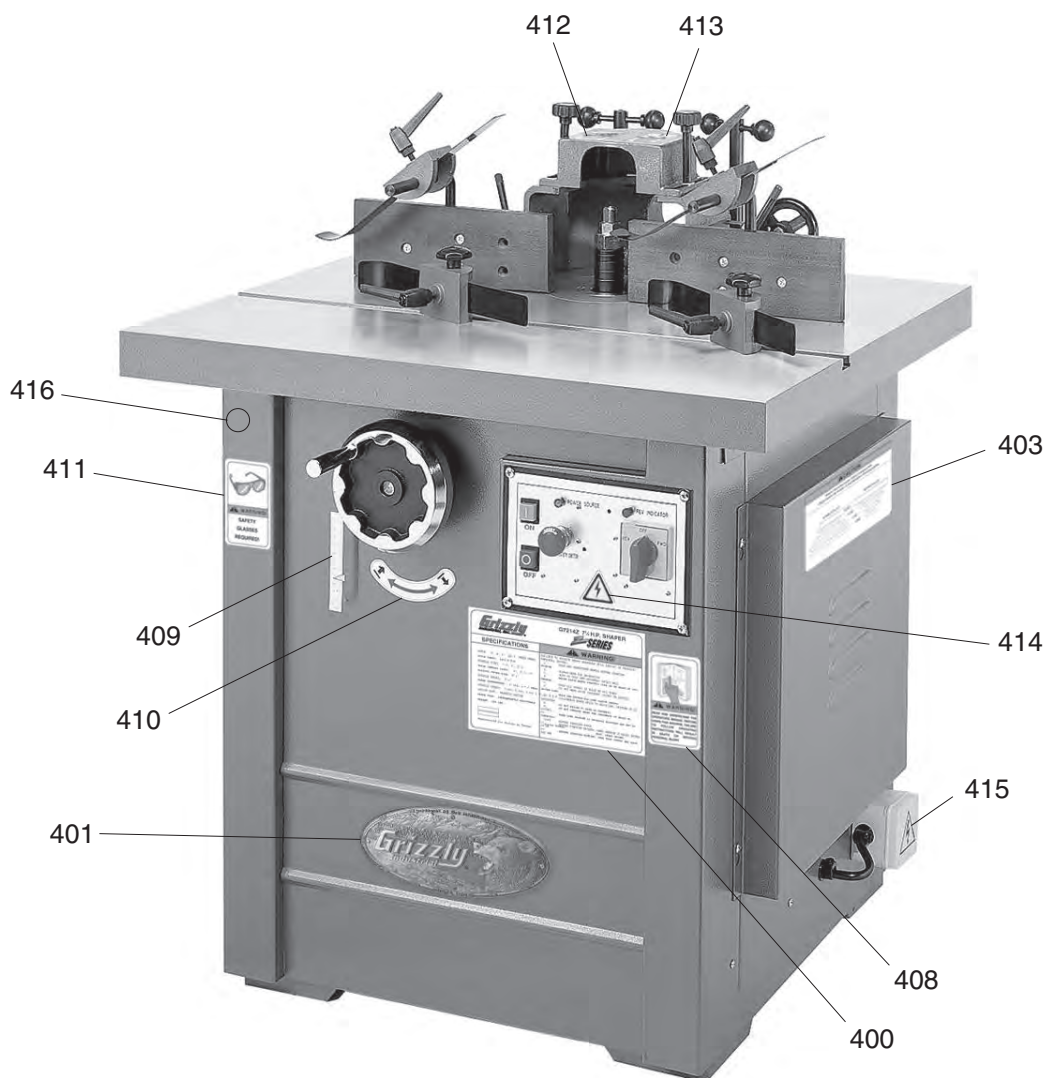

REF	PART #	DESCRIPTION
400	P5912Z400	G5912Z MACHINE ID LABEL
400	P7214Z400	G7214Z MACHINE ID LABEL
401	P5912Z401	GRIZZLY NAME PLATE
402	P5912Z402	PULLEY LABEL
403	P5912Z403	SPEED CHANGE LABEL
408	P5912Z408	READ MANUAL LABEL
409	P5912Z409	SCALE LABEL

REF	PART #	DESCRIPTION
410	P5912Z410	ROTATION DIRECTION LABEL
411	P5912Z411	SAFETY GLASSES LABEL
412	P5912Z412	HAND NEAR CUTTER LABEL
413	P5912Z413	UNPLUG LABEL
414	P5912Z414	ELECTRICITY LABEL
415	P5912Z415	LARGE ELECTRICITY LABEL
416	P5912Z416	"GRIZZLY GREEN" TOUCH-UP PAINT

WARNING

Safety labels help reduce the risk of serious injury caused by machine hazards. If any label comes off or becomes unreadable, the owner of this machine **MUST** replace it in the original location before resuming operations. For replacements, contact (800) 523-4777 or www.grizzly.com.

