

Replaces Page 72

Main Electrical Panel and Controls Diagram

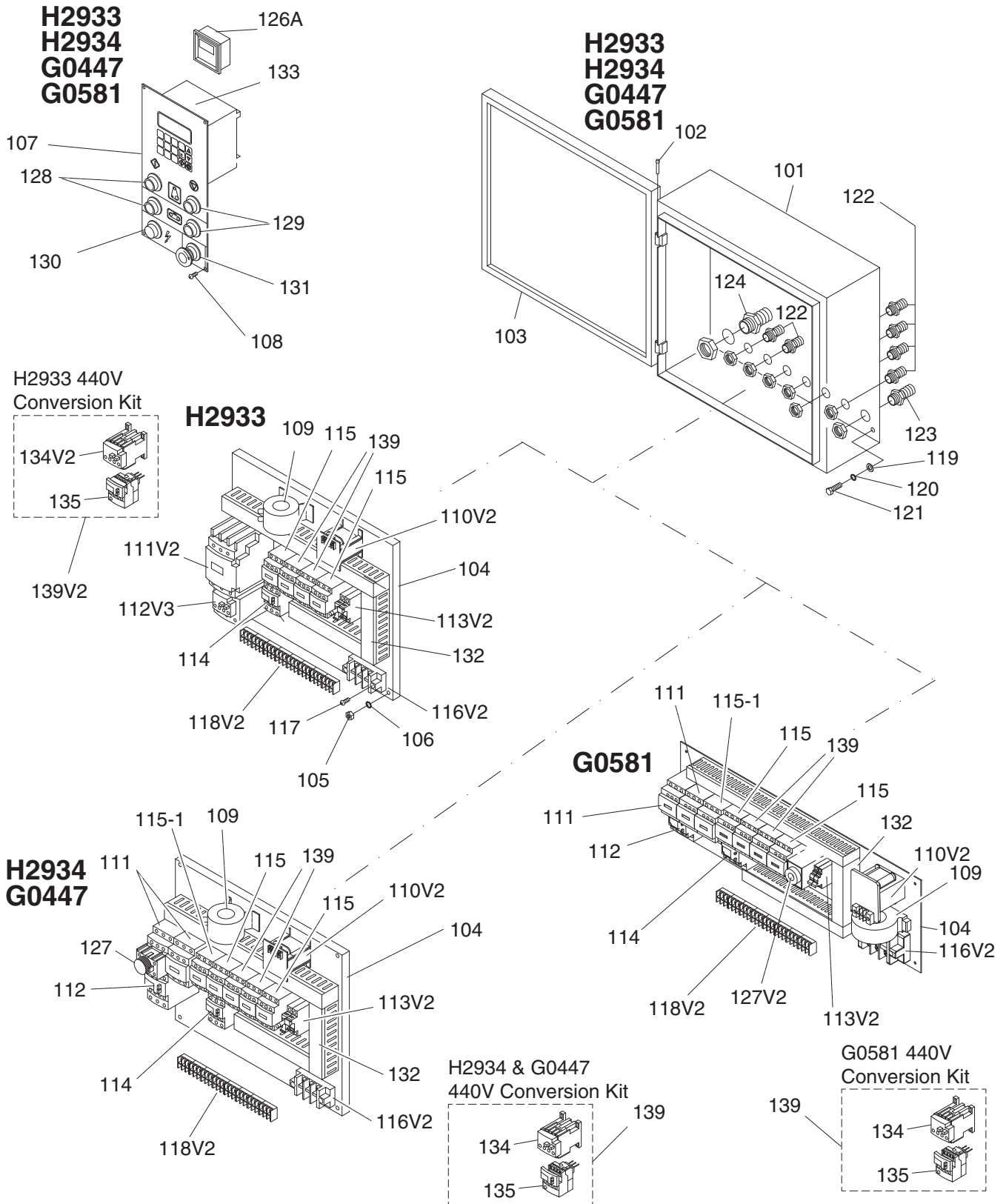

Replaces Page 73

Electrical Parts List

REF	PART #	DESCRIPTION
101	PH29338101	ELECTRICAL CONTROL BOX (H2933)
101	PH29348101	ELECTRICAL CONTROL BOX (G0447/H2934)
101	P05818101	ELECTRICAL CONTROL BOX (G0581)
102	PH29338102	HINGE
103	PH29348103	DOOR (G0447/H2934)
103	P05818103	DOOR (G0581)
103	PH29338103	DOOR (H2933)
104	PH29338104	BASE PLATE (H2933)
104	PH29348104	BASE PLATE (G0447/H2934)
104	P05818104	BASE PLATE (G0581)
105	PN05	HEX NUT 1/4-20
106	PLW02	LOCK WASHER 1/4
107	PH29338107	CONTROL PANEL
108	PS07M	PHLP HD SCR M4-.7 X 8
109	PH29338109	CURRENT SENSOR
110V2	PH29338110V2	TRANSFORMER V2.03.10
111	PH29348111	CONTACTOR SCHN LC1D38 220V (G0447/G0581/H2934)
111V2	PH29338111V2	CONTACTOR SCHN LC1D40A 220V V2.04.13 (H2933)
112	PH29348112	OL RELAY SCHN LR3D32 23-32A (G0447/H2934)
112	P05818112	OL RELAY SCHN LR3D35 30-38A (G0581)
112V3	P0539012V3	OL RELAY SCHN LRD340 30-40A V3.04.13 (H2933)
113V2	PH29338113V2	FUSE 4A V2.03.10
114	PH29338114	OL RELAY SCHN LR3D08 2.5-4A (G0447/H2933/H2934)
114	P05818114	OL RELAY SCHN LR3D12 5.5-8A (G0581)

REF	PART #	DESCRIPTION
115	PH29338115	CONTACTOR SCHN LC1D09 220V
115-1	PH29348115-1	CONTACTOR SCHN LC1D25 220V
116V2	PH29348116V2	GROUND TERMINAL V2.03.10 (G0447/H2934)
116V2	P05818116V2	GROUND TERMINAL V2.03.10 (G0581)
116V2	PH29338116V2	GROUND TERMINAL V2.03.10 (H2933)
117	PS51M	PHLP HD SCR M4-.7 X 30
118V2	PH29338118V2	TERMINAL PLATE V2.03.10
119	PW06	FLAT WASHER 1/4
120	PLW02	LOCK WASHER 1/4
121	PB19	HEX BOLT 1/4-20 X 1/2
122	PH29338122	PU CONNECTOR 1/2"
123	PH29338123	PU CONNECTOR 3/4"
124	PH29338124	CABLE CONNECTOR 1"
126A	PH29338126A	DIGITAL AMP METER N/S
127	PH29348127	START DELAY LADS2 (G0447/H2934)
127V2	P05818127V2	START DELAY LSD V2.03.10 (G0581)
128	PH29338128	START SWITCH
129	PH29338129	STOP SWITCH
130	PH29338130	POWER INDICATION LIGHT
131	PH29338131	EMERGENCY STOP SWITCH
132	PH29338132	WIRE COLUMN (G0447/H2933/H2934)
132	P05818132	WIRE COLUMN (G0581)
133	PH29338133	COMPUTER
139	PH29338139	CONTACTOR SCHN LC1D09 220V W/LOCK

H2933 440V Conversion Kit

139V2	PH29339139V2	440V CONVERSION KIT
134V2	PH29338134V2	OL RELAY SCHN LR3D325 17-25A V2.04.13
135	PH29338135	OL RELAY SCHN LR3D07 1.6-2.5A

H2934 440V Conversion Kit

139	PH29349139	440V CONVERSION KIT
134	PH29348134	OL RELAY SCHN LR3D21 12-18A
135	PH29338135	OL RELAY SCHN LR3D07 1.6-2.5A

G0447 440V Conversion Kit

139	PH29349139	440V CONVERSION KIT
134	PH29348134	OL RELAY SCHN LR3D21 12-18A
135	PH29338135	OL RELAY SCHN LR3D07 1.6-2.5A

G0581 440V Conversion Kit

139	P05819139	440V CONVERSION KIT
134	PH29348134	OL RELAY SCHN LR3D21 12-18A
135	PH29338114	OL RELAY SCHN LR3D08 2.5-4A



Replaces Page 68

Upper Roller System Diagram

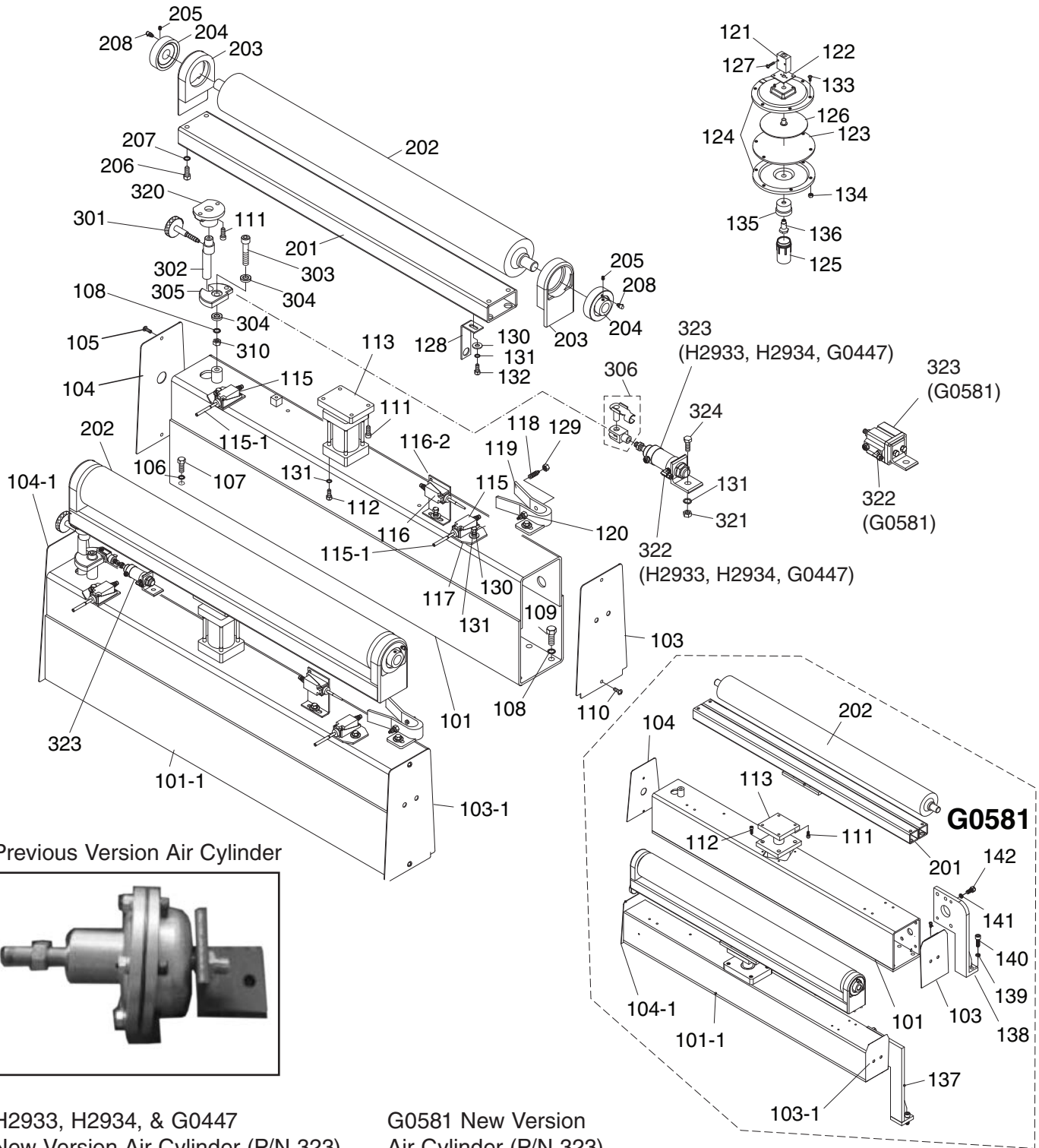

Previous Version Air Cylinder

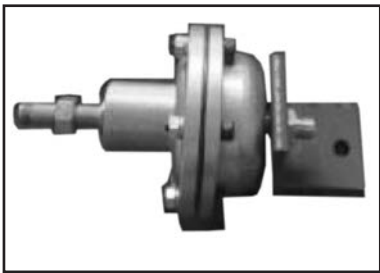

H2933, H2934, & G0447
New Version Air Cylinder (P/N 323)



G0581 New Version
Air Cylinder (P/N 323)

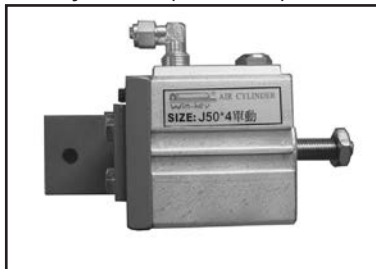

Replaces Page 69

Upper Roller System Parts List

REF	PART #	DESCRIPTION
101	PH29336101	SQUARE FRAME REAR (H2933)
101	PH29346101	SQUARE FRAME REAR (H2934)
101	P04476101	SQUARE FRAME REAR (G0447)
101	P05816101	SQUARE FRAME REAR (G0581)
101-1	PH29336101-1	SQUARE FRAME FRONT (H2933)
101-1	PH29346101-1	SQUARE FRAME FRONT (H2934)
101-1	P04476101-1	SQUARE FRAME FRONT (G0447)
101-1	P05816101-1	SQUARE FRAME FRONT (G0581)
103	PH29336103	FRAME SEAL RIGHT (H2933)
103	PH29346103	FRAME SEAL RIGHT (H2934)
103	P04476103	FRAME SEAL RIGHT (G0447)
103	P05816103	FRAME SEAL RIGHT (G0581)
103-1	PH29336103-1	FRAME SEAL FRONT (H2933)
103-1	PH29346103-1	FRAME SEAL FRNT RT (H2934)
103-1	P04476103-1	FRAME SEAL FRNT RT (G0447)
103-1	P05816103-1	FRAME SEAL FRNT RT (G0581)
104	PH29336104	FRAME SEAL LEFT (H2933)
104	PH29346104	FRAME SEAL LEFT (H2934)
104	P04476104	FRAME SEAL LEFT (G0447)
104	P05816104	FRAME SEAL LEFT (G0581)
104-1	PH29336104-1	FRAME SEAL FRNT LFT (H2933)
104-1	PH29346104-1	FRAME SEAL FRNT LFT (H2934)
104-1	P04476104-1	FRAME SEAL FRNT LFT (G0447)
104-1	P05816104-1	FRAME SEAL FRNT LFT (G0581)
105	PFH03	FLAT HD SCR 1/4-20 X 1/2
106	PLW04	LOCK WASHER 3/8
107	PB18	HEX BOLT 3/8-16 X 1
108	PLW07	LOCK WASHER 1/2
109	PB53	HEX BOLT 1/2-12 X 1
110	PS04	PHLP HD SCR 1/4-20 X 1/2
111	PSB07	CAP SCREW 5/16-18 X 3/4
112	PB03	HEX BOLT 5/16-18 X 1
113	PH29336113	AIR CYLINDER
115	PH29336115	LIMIT SWITCH W/CERAMIC TIP
115-1	PH29336115-1	CERAMIC TIP
116	PH29336116	LIMIT SWITCH W/PLASTIC TIP
116-2	PH29336116-2	LIMIT SWITCH HOLDER, L-TYPE
117	PH29336117	LIMIT SWITCH HOLDER
118	PH29336118	AIR SENSOR NOZZLE FEMALE
119	PH29336119	AIR FORK
120	PH29336120	AIR SENSOR NOZZLE MALE
121	PH29336121	THROTTLE VALVE
122	PH29336122	THROTTLE VALVE BASE
123	PH29336123	PLATE
124	PH29336124	HOUSING ASSEMBLY
125	PH29336125	OIL CAP

REF	PART #	DESCRIPTION
126	PH29336126	ALUMINUM PLATE
127	PS02M	PHLP HD SCR M4-.7 X 12
128	PH29336128	SHUTDOWN BRACKET
129	PN11	HEX NUT 3/8-24
130	PW07	FLAT WASHER 5/16
131	PLW01	LOCK WASHER 5/16
132	PB09	HEX BOLT 5/16-18 X 1/2
133	PS08	PHLP HD SCR 10-24 X 3/4
134	PN07	HEX NUT 10-24
135	PH29336135	CONNECTOR OF OIL CAP
136	PH29336136	SHAFT OF OIL CAP
137	P0581137	BRACKET (G0581)
138	P0581138	BRACKET (G0581)
139	PSB08	CAP SCREW 5/16-18 X 1-1/2
140	PSB76	CAP SCREW 1/2-12 X 1-1/2
141	PLW07	LOCK WASHER 1/2
142	PB53	HEX BOLT 1/2-12 X 1
201	PH29336201	BRACKET (H2933, H2934, G0447)
201	P05816201	BRACKET (G0581)
202	P05816202	UPPER ROLLER (G0581)
202	PH29336202	UPPER ROLLER (H2933)
202	PH29346202	UPPER ROLLER (H2934/G0447)
203	PH29336203	UPPER ROLLER BRACKET
204	P99625204	BEARING UCC205
205	PSS02M	SET SCREW M6-1 X 6
206	PSB33	CAP SCREW 10-24 x 3/4
207	PLW04	LOCK WASHER 3/8
208	PH29336208	GREASE FITTING W/DUST CAP
301	P05816301	KNOB
302	PH29336302	ECCENTRIC ROD
303	PSB79	CAP SCREW 1/2-12 X 3-1/2
304	PW01	FLAT WASHER 1/2
305	PH29336305	ECCENTRIC PIECE
306	PH29336306	CLEVIS ASSEMBLY
310	PN06	HEX NUT 1/2-12
320	PH29336320	ECCENTRIC SHAFT FRAME
321	PN02	HEX NUT 5/16-18
322	PH29339124	CONNECTOR 1/4N X 1/8T X 90DEG (H2933, H2934, G0447)
322	P05819124	CONNECTOR 1/4N X 1/4T X 90DEG (G0581)
323	P0539499V2	OSCILLATING AIR CYLINDER 30 X 4 (H2933, H2934, G0447)
323	P05816323	OSCILLATING AIR CYLINDER 50 X 4 (G0581)
324	PB11	HEX BOLT 5/16-18 X 1-1/2



Replaces Page 74 & 75

Belt Oscillation System

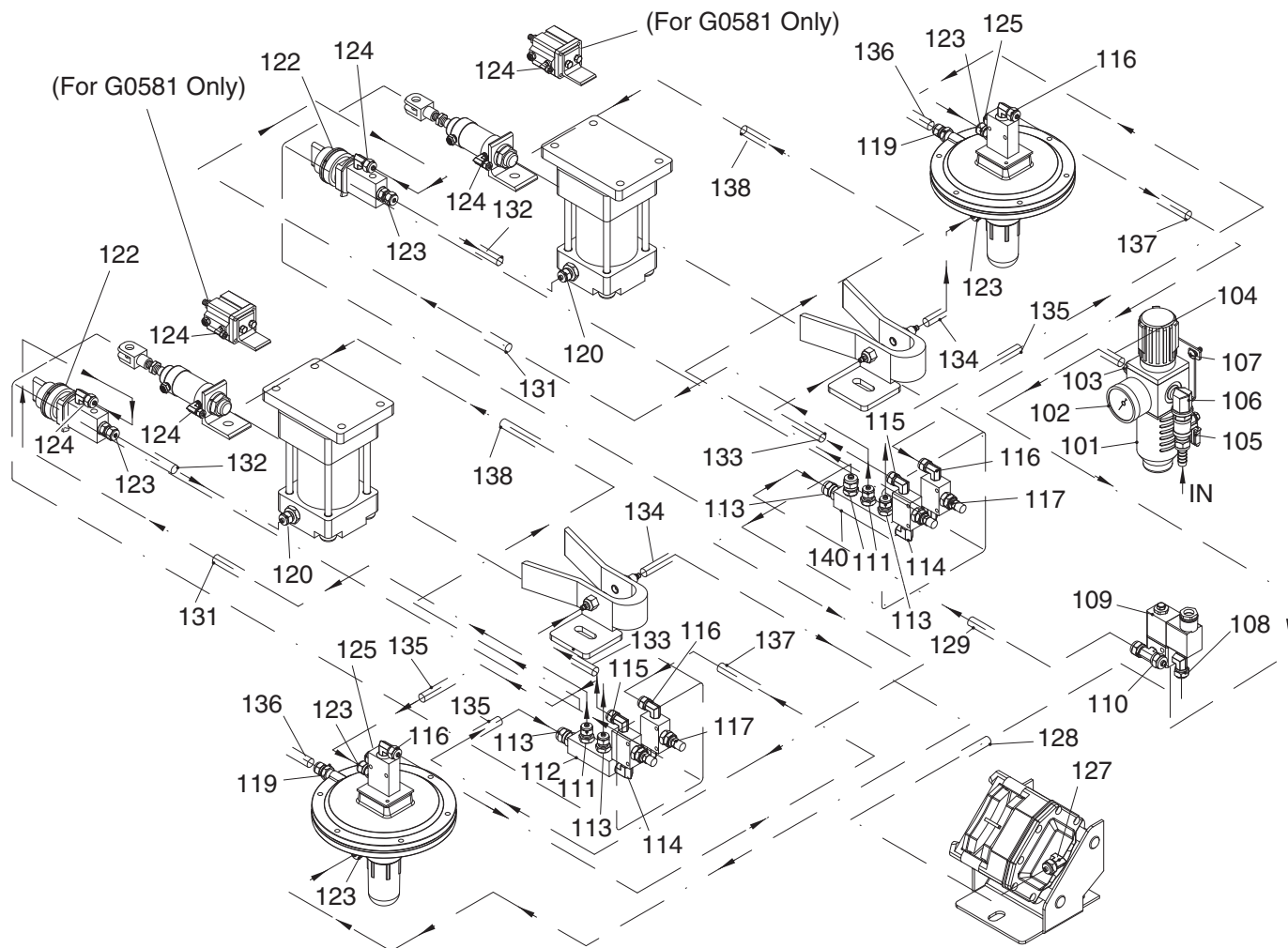

REF	PART #	DESCRIPTION
101	PH29339101	FILTER CUP
102	PH29339102	REGULATOR W/GAUGE
103	PH29339103	CONNECTOR, BRONZE
104	PH29339104	FLEXIBLE HOSE 6MM
105	PH29339105	AIR SWITCH
106	PH29339106	ELBOW
107	PH29339107	PHLP HD SCR 10-24 x 5/8
108	PH29339108	ELBOW 5/16N X 1/8T 90°
109	PH29339109	SOLENOID VALVE
110	PH29339110	T-FITTING 5/16N X 5/16N X 1/8T
111	PH29339111	CONNECTOR 5/16 X 1/4T BRONZE
112	PH29339112	MANIFOLD 1/4N 2-PORT
113	PH29339113	CONNECTOR 1/4N X 1/4T
114	PH29339114	ELBOW 1/4T X 1/8T 90°
115	PH29339115	CONNECTOR 1/4N X 1/8T 90°
116	PH29339116	CONNECTOR 1/4N X 1/8T 90°
117	PH29339117	THROTTLE VALVE
119	PH29339119	CONNECTOR 1/4N
120	PH29339120	CONNECTOR 1/4N X 3/8T

REF	PART #	DESCRIPTION
122	PH29339122	AIR SWITCH
123	PH29339123	CONNECTOR 1/4N X 1/8T
124	PH29339124	CONNECTOR 1/4N X 1/8T 90° (H2933,H2934, G0447)
124	P05819124	CONNECTOR 1/4N X 1/8T 90° (H2933,H2934, G0447)
125	PH29339125	BUFFER
127	PH29339127	CONNECTOR 5/16N X 1/8T 90°
128	PH29339128	8MM FLEXIBLE HOSE
129	PH29339129	8MM FLEXIBLE HOSE
131	PH29339131	6MM FLEXIBLE HOSE
132	PH29339132	6MM FLEXIBLE HOSE
133	PH29339133	6MM FLEXIBLE HOSE
134	PH29339134	6MM FLEXIBLE HOSE
135	PH29339135	6MM FLEXIBLE HOSE
136	PH29339136	6MM FLEXIBLE HOSE
137	PH29339137	6MM FLEXIBLE HOSE
138	PH29339138	6MM FLEXIBLE HOSE
140	PH29339140	MANIFOLD 1/4N 3-PORT



READ THIS FIRST

Grizzly
Industrial, Inc.®

Models H2933, H2934,
G0447, & G0581

*****IMPORTANT UPDATE*****

For Machines Mfd. Since January, 2014
and Owner's Manual Revised October, 2005

For questions or help with this product contact Tech Support at (570) 546-9663 or techsupport@grizzly.com

The following changes were made to this machine since the owner's manual was printed:

- Obtained CSA certification meeting CSA C22.2 #105-1953 and UL 987-7th standards.
- Changed transformer, contactors, overload relays, terminal blocks, and wiring.
- Changed circuit requirements.
- Replaced oscillation diaphragm assembly with an air cylinder.

Note: At the top of each page is a note that indicates which page it replaces in the original manual. On the parts list, the new parts are designated with a "V2".

Aside from this information, all other content in the owner's manual applies and **MUST** be read and understood for your own safety. **IMPORTANT: Keep this update with the owner's manual for future reference.** For questions or help, contact our Tech Support at (570) 546-9663 or techsupport@grizzly.com.



COPYRIGHT © JUNE, 2010 BY GRIZZLY INDUSTRIAL, INC., REVISED APRIL, 2015 (ST)
**WARNING: NO PORTION OF THIS MANUAL MAY BE REPRODUCED IN ANY SHAPE
OR FORM WITHOUT THE WRITTEN APPROVAL OF GRIZZLY INDUSTRIAL, INC.**
#TS12965 PRINTED IN TAIWAN

Replaces Page 72

Main Electrical Panel and Controls Diagram

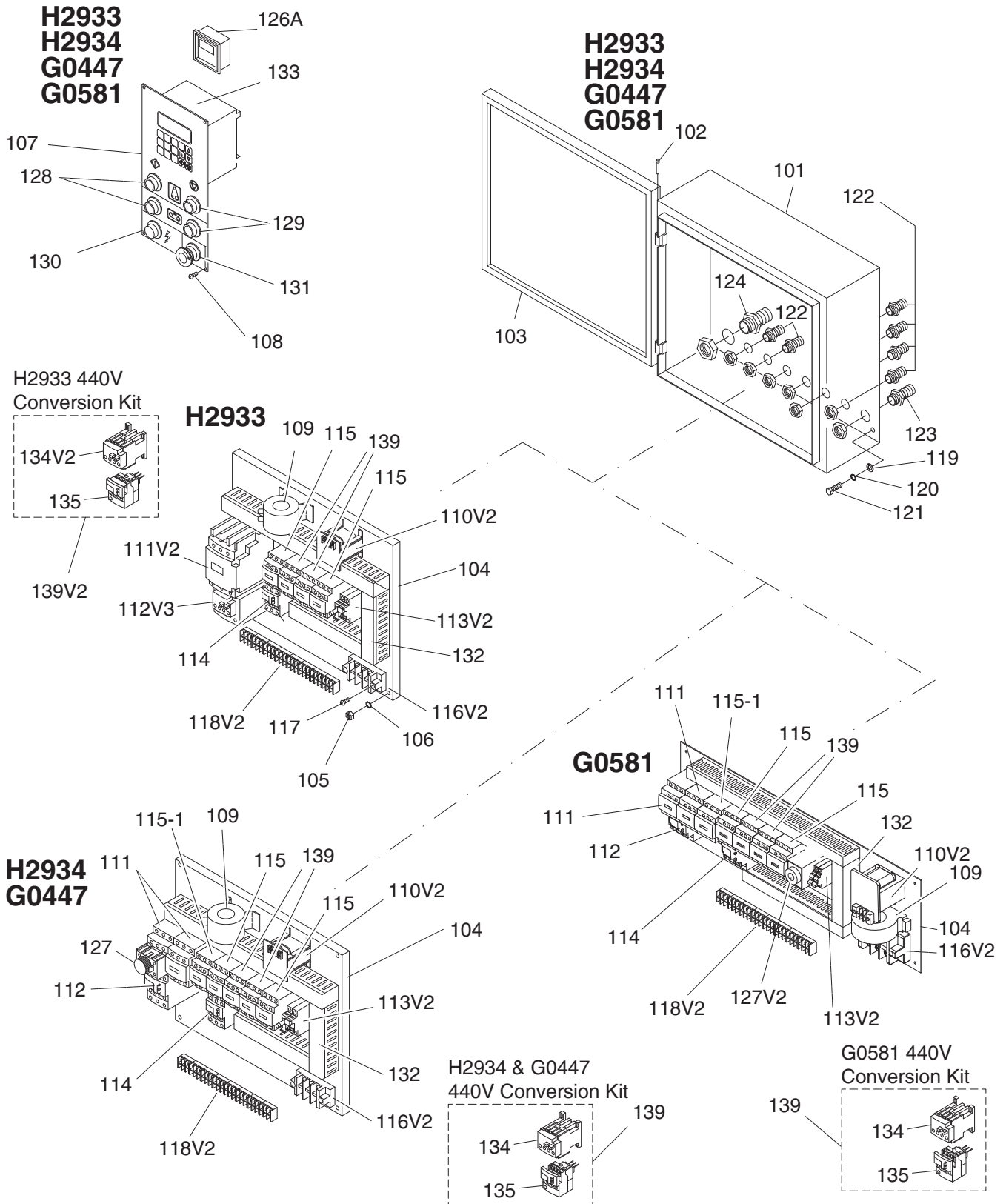

Replaces Page 73

Electrical Parts List

REF	PART #	DESCRIPTION
101	PH29338101	ELECTRICAL CONTROL BOX (H2933)
101	PH29348101	ELECTRICAL CONTROL BOX (G0447/H2934)
101	P05818101	ELECTRICAL CONTROL BOX (G0581)
102	PH29338102	HINGE
103	PH29348103	DOOR (G0447/H2934)
103	P05818103	DOOR (G0581)
103	PH29338103	DOOR (H2933)
104	PH29338104	BASE PLATE (H2933)
104	PH29348104	BASE PLATE (G0447/H2934)
104	P05818104	BASE PLATE (G0581)
105	PN05	HEX NUT 1/4-20
106	PLW02	LOCK WASHER 1/4
107	PH29338107	CONTROL PANEL
108	PS07M	PHLP HD SCR M4-.7 X 8
109	PH29338109	CURRENT SENSOR
110V2	PH29338110V2	TRANSFORMER V2.03.10
111	PH29348111	CONTACTOR SCHN LC1D38 220V (G0447/G0581/H2934)
111V2	PH29338111V2	CONTACTOR SCHN LC1D40A 220V V2.04.13 (H2933)
112	PH29348112	OL RELAY SCHN LR3D32 23-32A (G0447/H2934)
112	P05818112	OL RELAY SCHN LR3D35 30-38A (G0581)
112V3	P0539012V3	OL RELAY SCHN LRD340 30-40A V3.04.13 (H2933)
113V2	PH29338113V2	FUSE 4A V2.03.10
114	PH29338114	OL RELAY SCHN LR3D08 2.5-4A (G0447/H2933/H2934)
114	P05818114	OL RELAY SCHN LR3D12 5.5-8A (G0581)

REF	PART #	DESCRIPTION
115	PH29338115	CONTACTOR SCHN LC1D09 220V
115-1	PH29348115-1	CONTACTOR SCHN LC1D25 220V
116V2	PH29348116V2	GROUND TERMINAL V2.03.10 (G0447/H2934)
116V2	P05818116V2	GROUND TERMINAL V2.03.10 (G0581)
116V2	PH29338116V2	GROUND TERMINAL V2.03.10 (H2933)
117	PS51M	PHLP HD SCR M4-.7 X 30
118V2	PH29338118V2	TERMINAL PLATE V2.03.10
119	PW06	FLAT WASHER 1/4
120	PLW02	LOCK WASHER 1/4
121	PB19	HEX BOLT 1/4-20 X 1/2
122	PH29338122	PU CONNECTOR 1/2"
123	PH29338123	PU CONNECTOR 3/4"
124	PH29338124	CABLE CONNECTOR 1"
126A	PH29338126A	DIGITAL AMP METER N/S
127	PH29348127	START DELAY LADS2 (G0447/H2934)
127V2	P05818127V2	START DELAY LSD V2.03.10 (G0581)
128	PH29338128	START SWITCH
129	PH29338129	STOP SWITCH
130	PH29338130	POWER INDICATION LIGHT
131	PH29338131	EMERGENCY STOP SWITCH
132	PH29338132	WIRE COLUMN (G0447/H2933/H2934)
132	P05818132	WIRE COLUMN (G0581)
133	PH29338133	COMPUTER
139	PH29338139	CONTACTOR SCHN LC1D09 220V W/LOCK

H2933 440V Conversion Kit

139V2	PH29339139V2	440V CONVERSION KIT
134V2	PH29338134V2	OL RELAY SCHN LR3D325 17-25A V2.04.13
135	PH29338135	OL RELAY SCHN LR3D07 1.6-2.5A

H2934 440V Conversion Kit

139	PH29349139	440V CONVERSION KIT
134	PH29348134	OL RELAY SCHN LR3D21 12-18A
135	PH29338135	OL RELAY SCHN LR3D07 1.6-2.5A

G0447 440V Conversion Kit

139	PH29349139	440V CONVERSION KIT
134	PH29348134	OL RELAY SCHN LR3D21 12-18A
135	PH29338135	OL RELAY SCHN LR3D07 1.6-2.5A

G0581 440V Conversion Kit

139	P05819139	440V CONVERSION KIT
134	PH29348134	OL RELAY SCHN LR3D21 12-18A
135	PH29338114	OL RELAY SCHN LR3D08 2.5-4A



Replaces Page 68

Upper Roller System Diagram

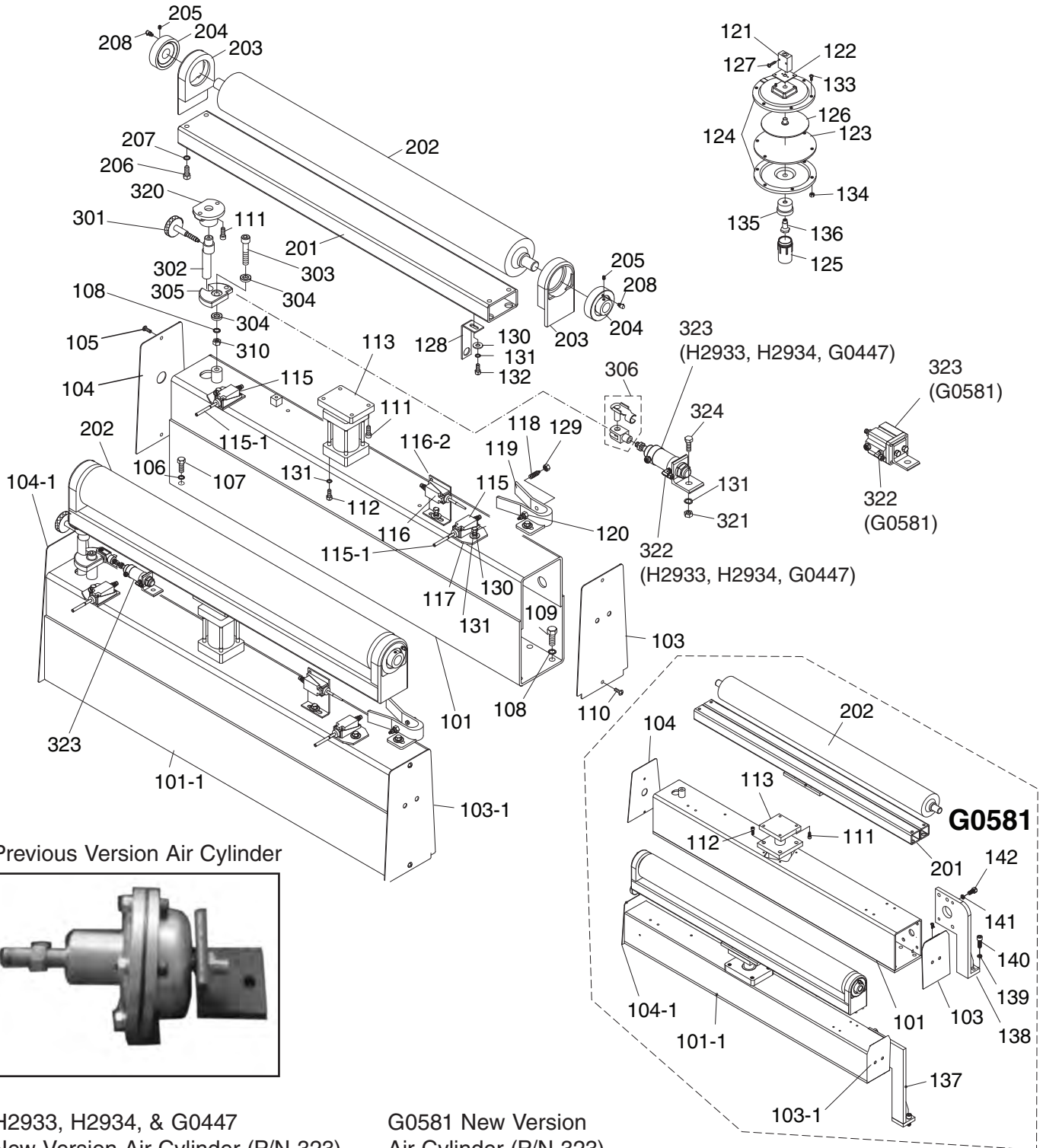

Previous Version Air Cylinder

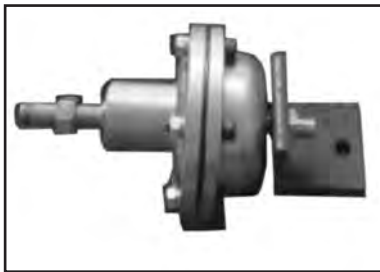

H2933, H2934, & G0447
New Version Air Cylinder (P/N 323)



G0581 New Version
Air Cylinder (P/N 323)



Replaces Page 69

Upper Roller System Parts List

REF	PART #	DESCRIPTION
101	PH29336101	SQUARE FRAME REAR (H2933)
101	PH29346101	SQUARE FRAME REAR (H2934)
101	P04476101	SQUARE FRAME REAR (G0447)
101	P05816101	SQUARE FRAME REAR (G0581)
101-1	PH29336101-1	SQUARE FRAME FRONT (H2933)
101-1	PH29346101-1	SQUARE FRAME FRONT (H2934)
101-1	P04476101-1	SQUARE FRAME FRONT (G0447)
101-1	P05816101-1	SQUARE FRAME FRONT (G0581)
103	PH29336103	FRAME SEAL RIGHT (H2933)
103	PH29346103	FRAME SEAL RIGHT (H2934)
103	P04476103	FRAME SEAL RIGHT (G0447)
103	P05816103	FRAME SEAL RIGHT (G0581)
103-1	PH29336103-1	FRAME SEAL FRONT (H2933)
103-1	PH29346103-1	FRAME SEAL FRNT RT (H2934)
103-1	P04476103-1	FRAME SEAL FRNT RT (G0447)
103-1	P05816103-1	FRAME SEAL FRNT RT (G0581)
104	PH29336104	FRAME SEAL LEFT (H2933)
104	PH29346104	FRAME SEAL LEFT (H2934)
104	P04476104	FRAME SEAL LEFT (G0447)
104	P05816104	FRAME SEAL LEFT (G0581)
104-1	PH29336104-1	FRAME SEAL FRNT LFT (H2933)
104-1	PH29346104-1	FRAME SEAL FRNT LFT (H2934)
104-1	P04476104-1	FRAME SEAL FRNT LFT (G0447)
104-1	P05816104-1	FRAME SEAL FRNT LFT (G0581)
105	PFH03	FLAT HD SCR 1/4-20 X 1/2
106	PLW04	LOCK WASHER 3/8
107	PB18	HEX BOLT 3/8-16 X 1
108	PLW07	LOCK WASHER 1/2
109	PB53	HEX BOLT 1/2-12 X 1
110	PS04	PHLP HD SCR 1/4-20 X 1/2
111	PSB07	CAP SCREW 5/16-18 X 3/4
112	PB03	HEX BOLT 5/16-18 X 1
113	PH29336113	AIR CYLINDER
115	PH29336115	LIMIT SWITCH W/CERAMIC TIP
115-1	PH29336115-1	CERAMIC TIP
116	PH29336116	LIMIT SWITCH W/PLASTIC TIP
116-2	PH29336116-2	LIMIT SWITCH HOLDER, L-TYPE
117	PH29336117	LIMIT SWITCH HOLDER
118	PH29336118	AIR SENSOR NOZZLE FEMALE
119	PH29336119	AIR FORK
120	PH29336120	AIR SENSOR NOZZLE MALE
121	PH29336121	THROTTLE VALVE
122	PH29336122	THROTTLE VALVE BASE
123	PH29336123	PLATE
124	PH29336124	HOUSING ASSEMBLY
125	PH29336125	OIL CAP

REF	PART #	DESCRIPTION
126	PH29336126	ALUMINUM PLATE
127	PS02M	PHLP HD SCR M4-.7 X 12
128	PH29336128	SHUTDOWN BRACKET
129	PN11	HEX NUT 3/8-24
130	PW07	FLAT WASHER 5/16
131	PLW01	LOCK WASHER 5/16
132	PB09	HEX BOLT 5/16-18 X 1/2
133	PS08	PHLP HD SCR 10-24 X 3/4
134	PN07	HEX NUT 10-24
135	PH29336135	CONNECTOR OF OIL CAP
136	PH29336136	SHAFT OF OIL CAP
137	P0581137	BRACKET (G0581)
138	P0581138	BRACKET (G0581)
139	PSB08	CAP SCREW 5/16-18 X 1-1/2
140	PSB76	CAP SCREW 1/2-12 X 1-1/2
141	PLW07	LOCK WASHER 1/2
142	PB53	HEX BOLT 1/2-12 X 1
201	PH29336201	BRACKET (H2933, H2934, G0447)
201	P05816201	BRACKET (G0581)
202	P05816202	UPPER ROLLER (G0581)
202	PH29336202	UPPER ROLLER (H2933)
202	PH29346202	UPPER ROLLER (H2934/G0447)
203	PH29336203	UPPER ROLLER BRACKET
204	P99625204	BEARING UCC205
205	PSS02M	SET SCREW M6-1 X 6
206	PSB33	CAP SCREW 10-24 x 3/4
207	PLW04	LOCK WASHER 3/8
208	PH29336208	GREASE FITTING W/DUST CAP
301	P05816301	KNOB
302	PH29336302	ECCENTRIC ROD
303	PSB79	CAP SCREW 1/2-12 X 3-1/2
304	PW01	FLAT WASHER 1/2
305	PH29336305	ECCENTRIC PIECE
306	PH29336306	CLEVIS ASSEMBLY
310	PN06	HEX NUT 1/2-12
320	PH29336320	ECCENTRIC SHAFT FRAME
321	PN02	HEX NUT 5/16-18
322	PH29339124	CONNECTOR 1/4N X 1/8T X 90DEG (H2933, H2934, G0447)
322	P05819124	CONNECTOR 1/4N X 1/4T X 90DEG (G0581)
323	P0539499V2	OSCILLATING AIR CYLINDER 30 X 4 (H2933, H2934, G0447)
323	P05816323	OSCILLATING AIR CYLINDER 50 X 4 (G0581)
324	PB11	HEX BOLT 5/16-18 X 1-1/2



Replaces Page 74 & 75

Belt Oscillation System

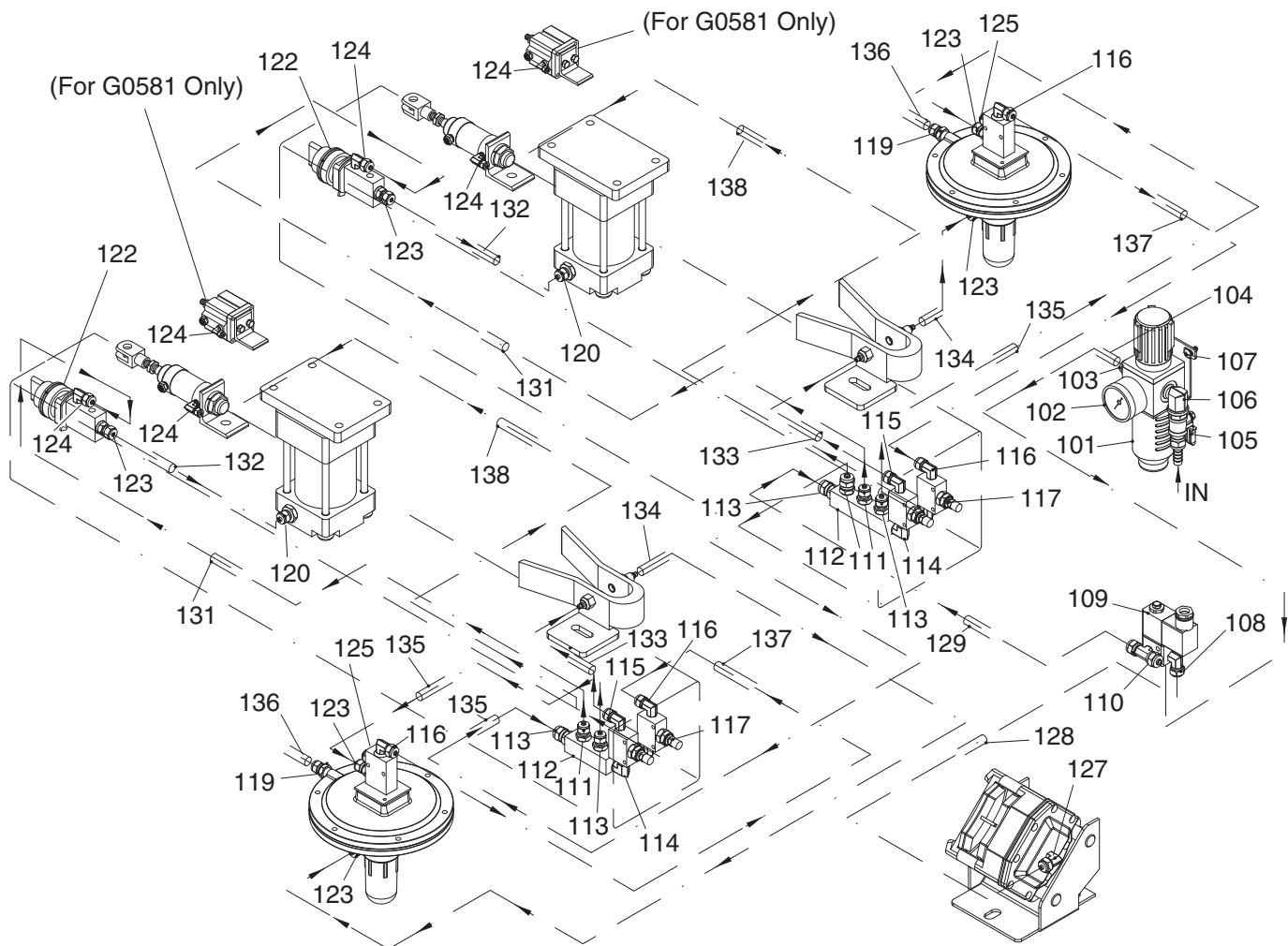

REF	PART #	DESCRIPTION
101	PH29339101	FILTER CUP
102	PH29339102	REGULATOR W/GAUGE
103	PH29339103	CONNECTOR, BRONZE
104	PH29339104	FLEXIBLE HOSE 6MM
105	PH29339105	AIR SWITCH
106	PH29339106	ELBOW
107	PS22	PHLP HD SCR 10-24 x 5/8
108	PH29339108	ELBOW 5/16N X 1/8T 90°
109	PH29339109	SOLENOID VALVE
110	PH29339110	T-FITTING 5/16N X 5/16N X 1/8T
111	PH29339111	BRONZE CONNECTOR 5/16 X 1/4T
112	PH29339112	MANIFOLD 1/4N
113	PH29339113	CONNECTOR 1/4N X1/4T
114	PH29339114	ELBOW 1/4T X 1/8T 90°
115	PH29339115	CONNECTOR 1/4N X 1/8T 90°
116	PH29339116	CONNECTOR 1/4N X 1/8T 90°
117	PH29339117	THROTTLE VALVE
119	PH29339119	CONNECTOR 1/4N
120	PH29339120	CONNECTOR 1/4N X 3/8T

REF	PART #	DESCRIPTION
122	PH29339122	AIR SWITCH
123	PH29339123	CONNECTOR 1/4N X 1/8T
124	PH29339124	CONNECTOR 1/4N X 1/8T 90° (H2933, H2934, G0447)
124	P05819124	CONNECTOR 1/4N X 1/4T 90° (G0581)
125	PH29339125	BUFFER
127	PH29339127	CONNECTOR 5/16N X 1/8T 90°
128	PH29339128	8MM FLEXIBLE HOSE
129	PH29339129	8MM FLEXIBLE HOSE
131	PH29339131	6MM FLEXIBLE HOSE
132	PH29339132	6MM FLEXIBLE HOSE
133	PH29339133	6MM FLEXIBLE HOSE
134	PH29339134	6MM FLEXIBLE HOSE
135	PH29339135	6MM FLEXIBLE HOSE
136	PH29339136	6MM FLEXIBLE HOSE
137	PH29339137	6MM FLEXIBLE HOSE
138	PH29339138	6MM FLEXIBLE HOSE



Tool Box and Accessories Diagram

0000 Series Parts

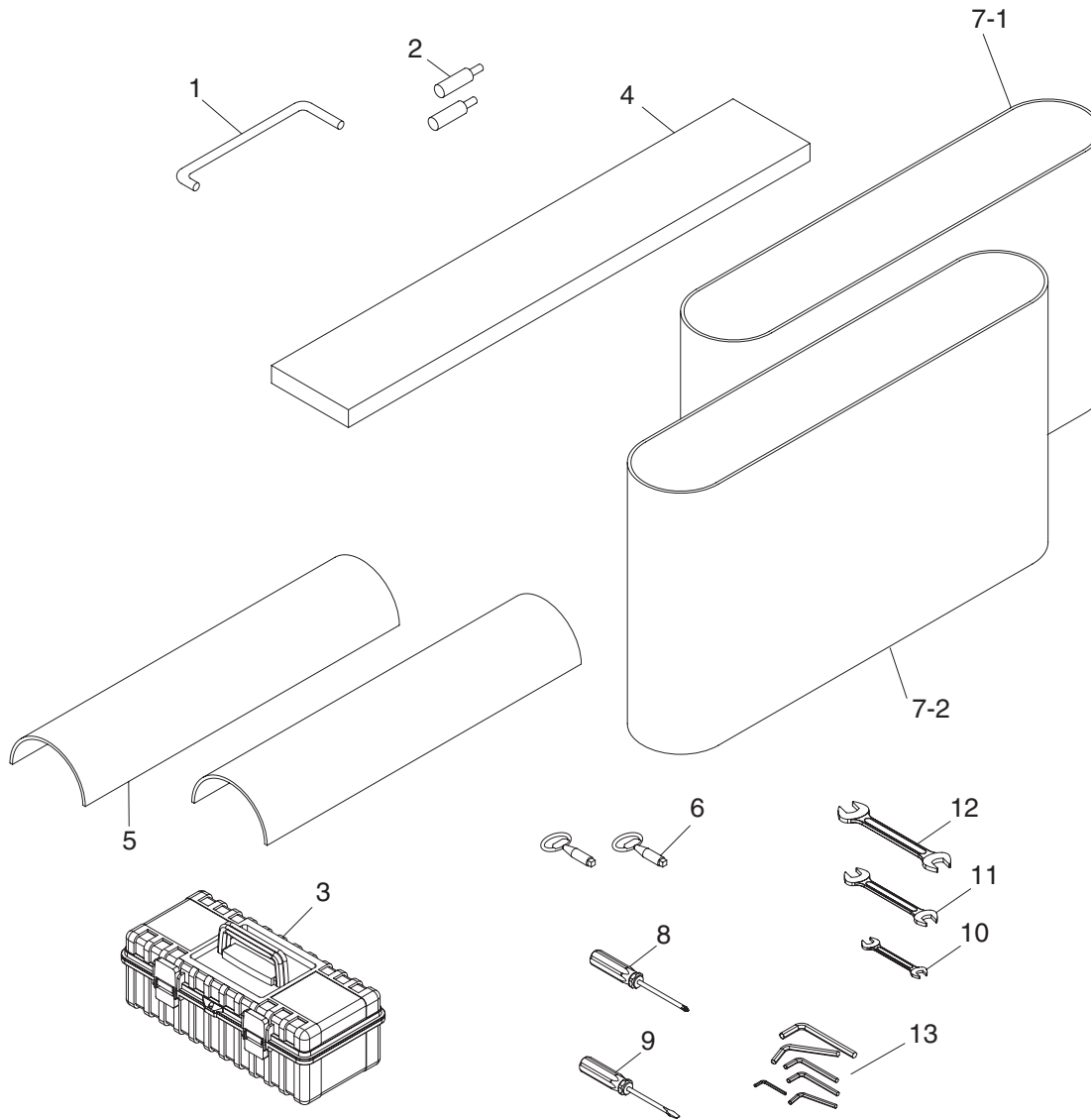

Tool Box and Accessories Parts List

REF	PART #	DESCRIPTION
1	PH29330001	PLATEN REMOVAL TOOL
2	PH29330002	CERAMIC LIMIT SWITCH TIP
3	PH29330003	TOOL BOX
4	PH29330004	25" FELT PLATEN PAD (H2933)
4	PH2934004	37-3/4" PLATEN FELT (H2934/G0447)
4	P058100004	44" PLATEN FELT (G0581)
5	PH29330005	GRAPHITE 25" X 3.54" (H2933)
5	PH29340005	GRAPHITE 37-3/4" X 3.54" (H2934/G0447)
5	P05810005	GRAPHITE 44" X 3.54" (G0581)
6	PH29330006	DOOR KEY
7-1	PH29330007-1	SANDPAPER #100 (25" X 60") (H2933)
7-1	PH29340007-1	SANDPAPER #100 (37" X 60") (H2934)

REF	PART #	DESCRIPTION
7-1	P04470007-1	SANDPAPER #100 (37" X 75") (G0447)
7-1	P05810007-1	SANDPAPER #100 (43" X 60") (G0581)
7-2	PH29330007-2	SANDPAPER #180 (25" X 60") (H2933)
7-2	PH29340007-2	SANDPAPER #180 (37" X 60") (H2934)
7-2	P04470007-2	SANDPAPER #180 (37" X 75") (G0447)
7-2	P05810007-2	SANDPAPER #180 (43" X 60") (G0581)
8	PH29330008	#2 PHILLIPS SCREWDRIVER
9	PH29330009	SCREWDRIVER FLAT #2
10	PH29330010	WRENCH 8 X 10
11	PH29330011	WRENCH 12 X 14
12	PH29330012	WRENCH 17 X 19
13	PH29330013	HEX WRENCH SET



Sanding Motor System Diagram

1000 Series Parts

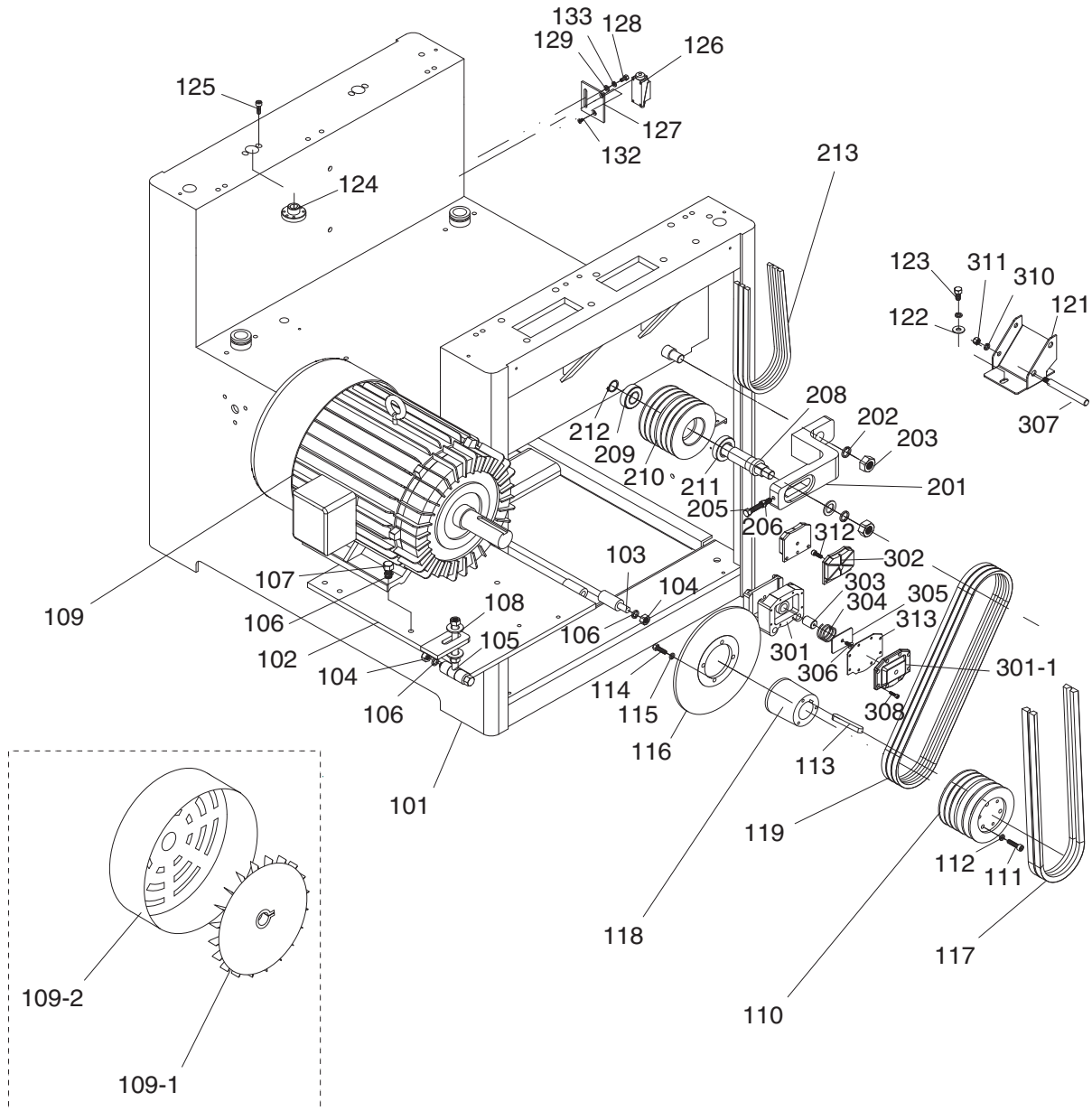

Sanding Motor System Parts List

REF	PART #	DESCRIPTION
101	PH29331101	MACHINE FRAME (H2933)
101	PH29341101	MACHINE FRAME (H2934/G0447)
101	P05811101	MACHINE FRAME (G0581)
102	PH29331102	MOTOR BASE (H2933)
102	PH29341102	MOTOR BASE (H2934/G0447)
102	P05811102	MOTOR BASE (G0581)
103	PH29331103	MOTOR BASE HINGE (H2933)
103	PH29341103	MOTOR BASE HINGE (H2934/G0447)
103	P05811103	MOTOR BASE HINGE (G0581)
104	PH29331104	HEX NUT 1/2-12
105	PH29331105	MOTOR BASE ADJUSTMENT ROD
106	PH29331106	LOCK WASHER 1/2
107	PH29331107	HEX BOLT 1/2-12 X 1-1/2
108	PH29331108	FLAT WASHER 1/2
109	PH29331109	MOTOR 15HP 220V/440V 3PH (H2933)
109	PH29341109	MOTOR 20HP 220V/440V 3PH (H2934/G0447)
109	P05811109	MOTOR 25HP 220V/440V 3PH (G0581)
109-1	PH29331109-1	MOTOR FAN (H2933)
109-1	PH29341109-1	MOTOR FAN (H2934/G0447)
109-1	P05811109-1	MOTOR FAN (G0581)
109-2	PH29331109-2	MOTOR FAN COVER (H2933)
109-2	PH29341109-2	MOTOR FAN COVER (H2934/G0447)
109-2	P05811109-2	MOTOR FAN COVER (G0581)
110	PH29331110	PULLEY (H2933)
110	PH29341110	PULLEY (H2934/G0447)
110	P05811110	PULLEY (G0581)
111	PH29331111	CAP SCREW 5/16-18 X 1-1/4
112	PH29331112	LOCK WASHER 5/16
113	PH29331113	KEY 12 X 8 X105
114	PH29331114	HEX BOLT 5/16-18 X 1
115	PH29331115	LOCK WASHER 5/16
116	PH29331116	ROTOR
117	PH29331117	V-BELT B-76 5L760
118	PH29331118	PULLEY BUSHING (H2933)

REF	PART #	DESCRIPTION
118	PH29341118	PULLEY BUSHING (H2934/G0447)
118	P05811118	PULLEY BUSHING (G0581)
119	PH29331119	V-BELT A-50 4L500
121	PH29331121	BRAKE BRACKET
122	PH29331122	FLAT WASHER 3/8
123	PH29331123	HEX BOLT 3/8-16 X 3/4
124	PH29331124	FLAT HEAD NUT
125	PH29331125	CAP SCREW 1/4-20 X 3/4
126	PH29331126	LIMIT SWITCH
127	PH29331127	LIMIT SWITCH PLATE
128	PH29331128	HEX BOLT 1/4-20 X 1/2
129	PH29331129	FLAT WASHER 1/4
132	PH29331132	FLAT HD SCR M6-1 X 25
133	PH29331133	LOCK WASHER 1/4
201	PH29331201	IDLE WHEEL ADJ BRACKET
202	PH29331202	LOCK WASHER 3/4
203	PH29331203	HEX NUT 1/2-12
205	PH29331205	HEX BOLT 3/8-16 X 3-1/2
206	PH29331206	HEX NUT 3/8-16
208	PH29331208	IDLE WHEEL SHAFT
209	PH29331209	BALL BEARING 6305ZZ
210	PH29331210	PULLEY
211	PH29331211	BALL BEARING 6206ZZ
212	PH29331212	EXT RETAINING RING 25MM
213	PH29331213	V-BELT A-40 4L400
301	PH29331301	BRAKE BRACKET
301-1	PH29331301-1	BREAK BRACKET FRONT GUARD
302	PH29331302	BRAKE LINING SET
303	PH29331303	BRAKE ARBOR
304	PH29331304	BRAKE COMPRESSION SPRING
305	PH29331305	BRAKE INSIDE PIECE
306	PH29331306	FLAT HD SCR 1/4-20 X 5/8
307	PH29331307	BRAKE PIN
308	PH29331308	CAP SCREW 10-24 X 5/8
310	PH29331310	LOCK WASHER 3/8
311	PH29331311	HEX NUT 3/8-16
312	PH29331312	CAP SCREW 1/4-20 X 1/2
313	PH29331313	BRAKE GASKET



Table Lift System Diagram

2000 Series Parts

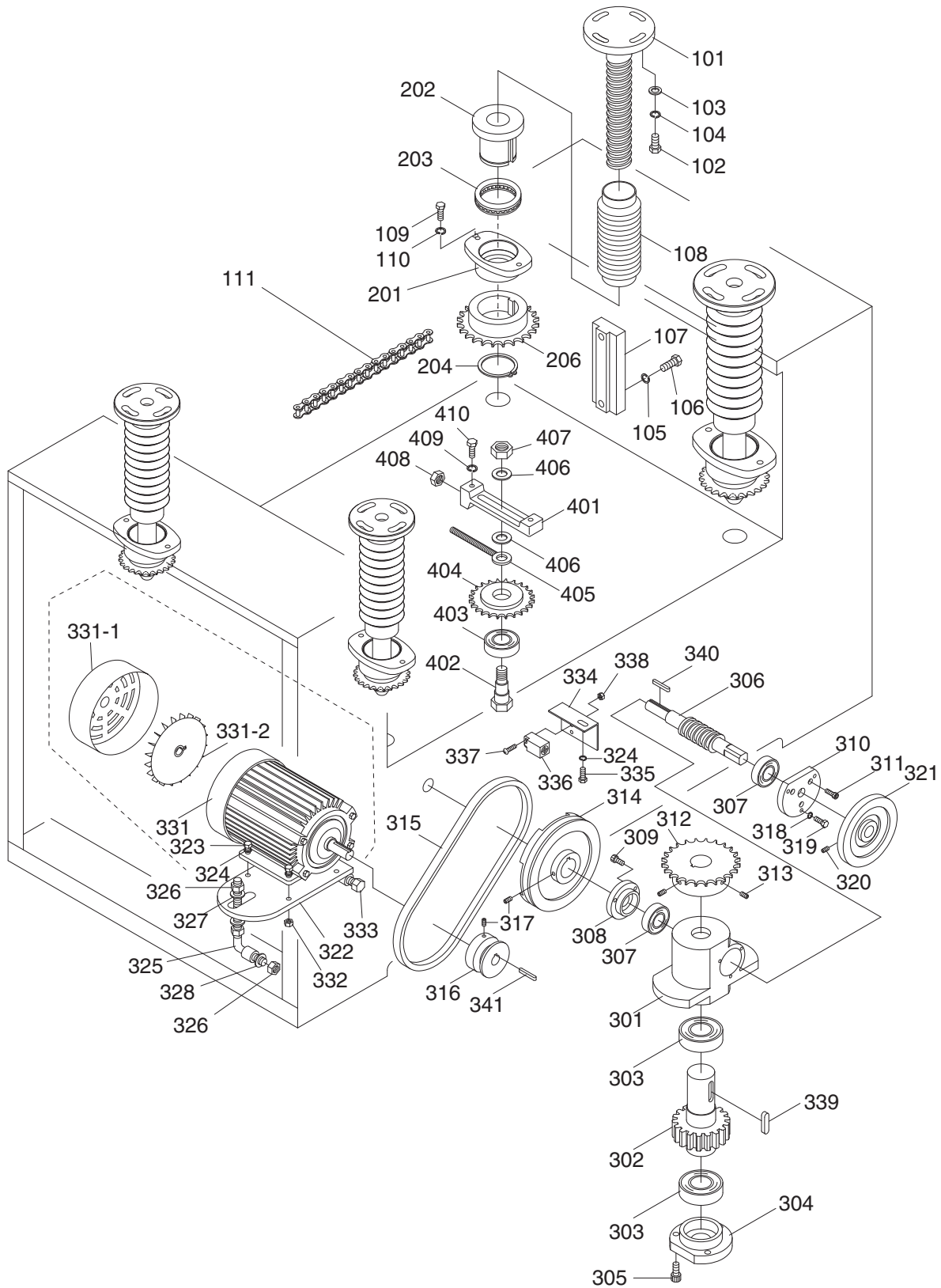

Table Lift System Parts List

REF	PART #	DESCRIPTION
101	PH29332101	ELEVATION SCREW
102	PH29332102	HEX BOLT 5/16-18 X 1
103	PH29332103	FLAT WASHER 5/16
104	PH29332104	LOCK WASHER 5/16
105	PH29332105	LOCK WASHER 3/8
106	PH29332106	HEX BOLT 3/8-16 X 1
107	PH29332107	ELEVATION SLIDE
108	PH29332108	DUST BOOT
109	PH29332109	HEX BOLT 5/16-18 X 3/4
110	PH29332110	LOCK WASHER 5/16
111	PH29332111	CHAIN (H2933)
111	PH29342111	CHAIN (H2934/G0447)
111	P05812111	CHAIN (G0581)
201	PH29332201	NUT HOUSING
202	PH29332202	NUT
203	PH29332203	THRUST BEARING 51107
204	PH29332204	EXT RETAINING RING 35MM
206	PH29332206	SPROCKET WHEEL
301	PH29332301	ELEVATION GEAR BOX
302	PH29332302	WORM GEAR
303	PH29332303	BALL BEARING 6005ZZ
304	PH29332304	BEARING CAP
305	PH29332305	CAP SCREW 1/4-20 X 3/4
306	PH29332306	WORM SHAFT
307	PH29332307	BALL BEARING 6002ZZ
308	PH29332308	BEARING CAP
309	PH29332309	CAP SCREW 10-24 x 3/4
310	PH29332310	BEARING CAP
311	PH29332311	CAP SCREW 1/4-20 X 5/8
312	PH29332312	SPROCKET WHEEL
313	PH29332313	SET SCREW 1/4-20 X 1/2
314	PH29332314	PULLEY
315	PH29332315	V-BELT A-36 4L360
316	PH29332316	PULLEY
317	PH29332317	SET SCREW 1/4-20 X 1/2

REF	PART #	DESCRIPTION
318	PH29332318	LOCK WASHER 5/16
319	PH29332319	HEX BOLT 5/16-18 X 3/4
320	PH29332320	SET SCREW 1/4-20 X 1/2
321	PH29332321	HAND WHEEL
322	PH29332322	MOTOR BASE
323	PH29332323	HEX BOLT 1/4-20 X 1
324	PH29332324	LOCK WASHER 1/4
325	PH29332325	ADJUSTMENT ROD
326	PH29332326	FLAT WASHER 1/2
327	PH29332327	HEX NUT 1/2-12
328	PH29332328	LOCK WASHER 1/2
331	PH29332331	MOTOR 1/4HP 220V/440V 3PH (ALL MODELS)
331-1	PH29332331-1	FAN COVER (ALL MODELS)
331-2	PH29332331-2	FAN (ALL MODELS)
332	PH29332332	HEX NUT 1/4-20
333	PH29332333	HEX BOLT 1/2-12 X 4-1/2
334	PH29332334	PROXIMITY SWITCH PLATE
335	PH29332335	HEX BOLT 1/4-20 X 1/2
336	PH29332336	PROXIMITY SWITCH
337	PH29332337	SPECIAL SCREW M3-.5 X 40
338	PH29332338	HEX NUT M3-.5
339	PH29332339	KEY 5/16 X 5/16 X 3/4
340	PH29332340	KEY 4 X 4 X 20
341	PH29332341	KEY 4 X 4 X 16
401	PH29332401	SPROCKET WHEEL ADJUSTOR
402	PH29332402	SPROCKET WHEEL SHAFT
403	PH29332403	BALL BEARING 6003ZZ
404	PH29332404	ADJUSTMENT SPROCKET
405	PH29332405	ADJUSTMENT ROD
406	PH29332406	FLAT WASHER 3/8
407	PH29332407	HEX NUT 3/8-16
408	PH29332408	HEX NUT 5/16-18
409	PH29332409	LOCK WASHER 5/16
410	PH29332410	HEX BOLT 5/16-18 X 3/4



Conveyor System Diagram

3000 Series Parts

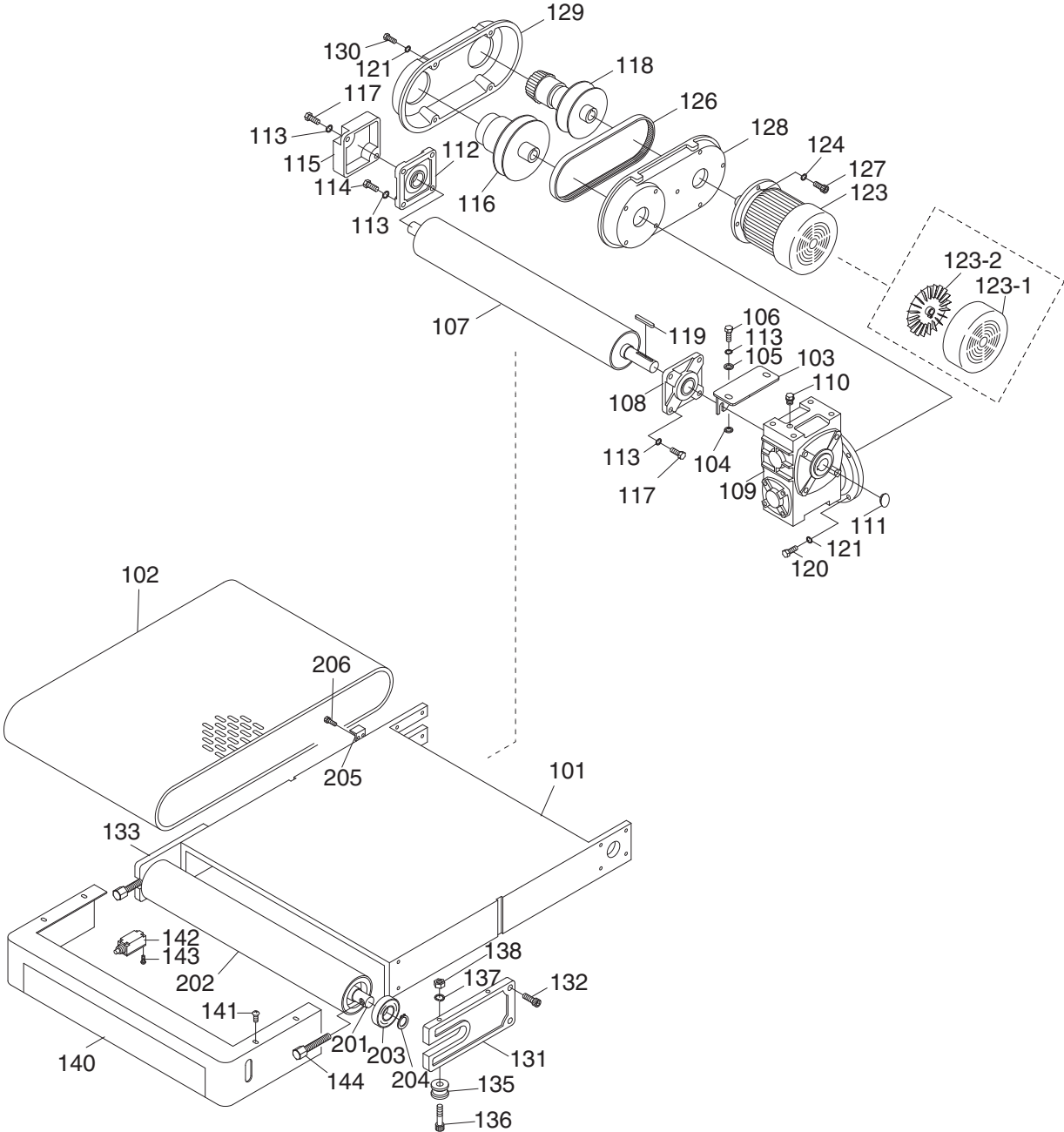

Conveyor System Parts List

REF	PART #	DESCRIPTION
101	PH29333101	CONVEYOR TABLE (H2933)
101	PH29343101	CONVEYOR TABLE (H2934/G0447)
101	P05813101	CONVEYOR TABLE (G0581)
102	PH29333102	CONVEYOR BELT (H2933)
102	PH29343102	CONVEYOR BELT (H2934/G0447)
102	P05813102	CONVEYOR BELT (G0581)
103	PH29333103	REDUCER FIX PLATE
104	PH29333104	CUSHION
105	PH29333105	LOCK WASHER 3/8
106	PH29333106	HEX BOLT 3/8-16 X 1
107	PH29333107	OUTFEED ROLLER (H2933)
107	PH29343107	OUTFEED ROLLER (H2934/G0447)
107	P05813107	OUTFEED ROLLER (G0581)
108	PH29333108	BEARING UCF206
109	PH29333109	GEARBOX
110	PH29333110	BREATHER
111	PH29333111	PLUG
112	PH29333112	BALL BEARING UCF205
113	PH29333113	LOCK WASHER 3/8
114	PH29333114	HEX BOLT 3/8-16 X 1-1/4
115	PH29333115	BEARING CAP
116	PH29333116	DRIVEN PULLEY
117	PH29333117	HEX BOLT 3/8-16 X 1-1/2
118	PH29333118	DRIVING PULLEY
119	PH29333119	KEY 7 X 7 X 55
120	PH29333120	HEX BOLT M8-1.25 X 25
121	PH29333121	LOCK WASHER 8MM
123	PH29333123	MOTOR 1HP 220V/440V 3PH (H2933, H2934, G0447)
123	P05813123	MOTOR 2HP 220V/440V 3PH (G0581)
123-1	PH29333123-1	MOTOR FAN COVER (H2933, H2934, G0447)

REF	PART #	DESCRIPTION
123-1	P05813123-1	MOTOR FAN COVER (G0581)
123-2	PH29333123-2	MOTOR FAN (H2933, H2934, G0447)
123-2	P05813123-2	MOTOR FAN (G0581)
124	PH29333124	LOCK WASHER 5/8
126	PH29333126	TIMING BELT 1422V-290
127	PH29333127	CAP SCREW M10-1.5 X 25
128	PH29333128	BASE PLATE
129	PH29333129	VARIABLE SPEED UNIT COVER
130	PH29333130	HEX BOLT M8-1.25 X 20
131	PH29333131	INFEED ROLLER BRACKET
132	PH29333132	CAP SCREW 10-24 x 3/4
133	PH29333133	INFEED ROLLER BRACKET
135	PH29333135	CONVEYOR POSITION WHEEL
136	PH29333136	CAP SCREW 5/16-18 X 2
137	PH29333137	LOCK WASHER 5/16
138	PH29333138	HEX NUT 5/16-18
140	PH29333140	EMGNKY BRAKE PUSH-PLATE (H2933)
140	PH29343140	EMGNKY BRAKE PUSH-PLATE (H2934/G0447)
140	P05813140	EMGNKY BRAKE PUSH-PLATE (G0581)
141	PH29333141	PHLP HD SCR 1/4-20 X 1/2
142	PH29333142	LIMIT SWITCH
143	PH29333143	PHLP HD SCR 10-24 x 1 1/2
144	PH29333144	HEX BOLT 1/2-12 X 3
201	PH29333201	INFEED ROLLER SHAFT
202	PH29333202	INFEED ROLLER (H2933)
202	PH29343202	INFEED ROLLER (H2934/G0447)
202	P05813202	INFEED ROLLER (G0581)
203	PH29333203	BALL BEARING 6206ZZ
204	PH29333204	EXT RETAINING RING 30MM
205	PH29333205	ELEVATION LIMITER
206	PH29333206	CAP SCREW 1/4-20 X 1-1/2



Feed, Drum, and Pressure Roller Diagram

4000 Series Parts

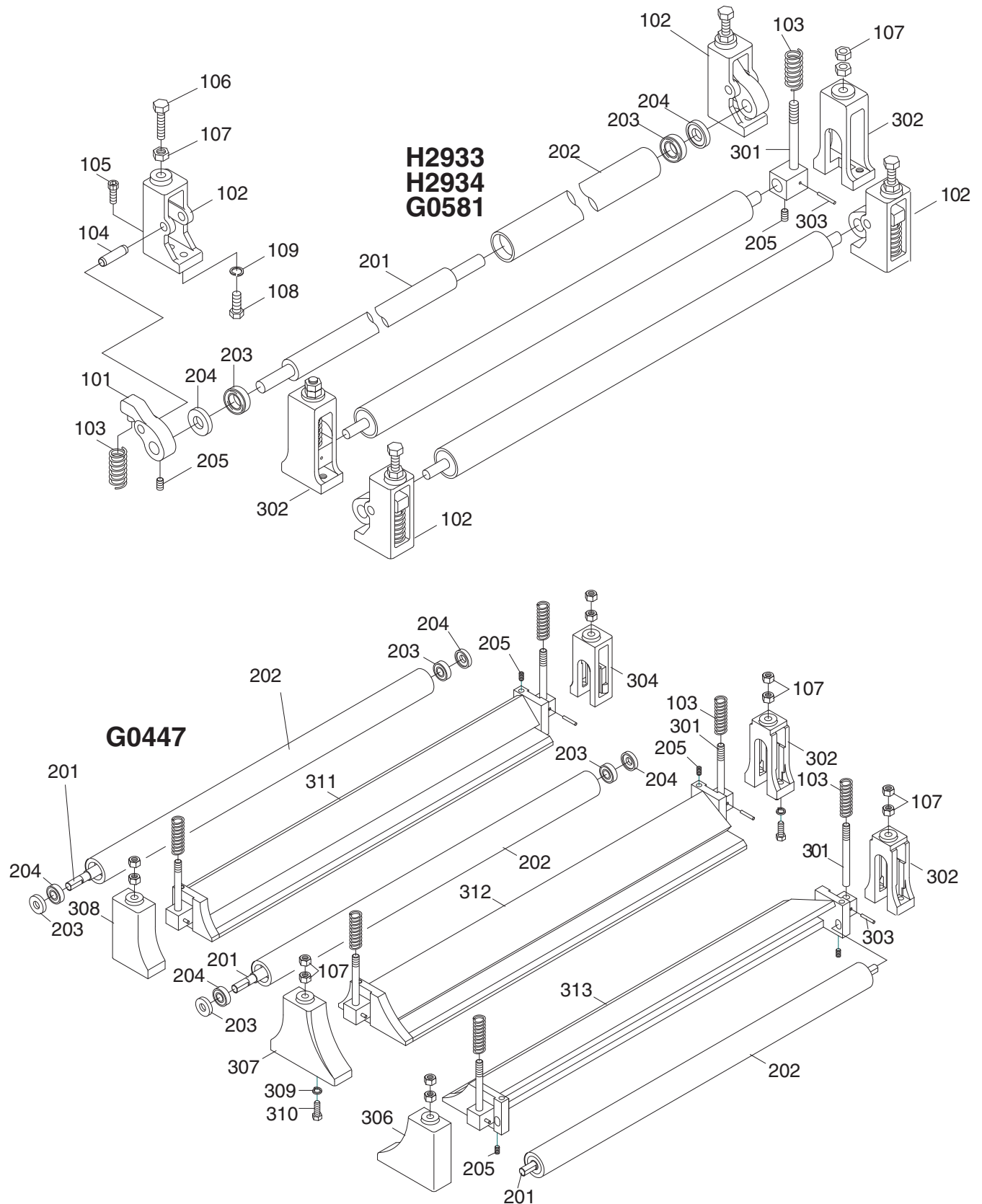

Feed, Drum, and Pressure Roller Parts List

REF	PART #	DESCRIPTION
101	PH29334101	PISTON SLIDERAIL
102	PH29334102	PISTON BRACKET OUTER (H2933/H2934/G0581)
103	PH29334103	COMPRESSION SPRING
104	PH29334104	ROD 10 X 35
105	PH29334105	SET SCREW 1/4-20 X 1/2
106	PH29334106	HEX BOLT 5/16-18 X 1-1/2
107	PH29334107	HEX NUT 5/16-18
108	PH29334108	HEX BOLT 5/16-18 X 1-1/4
109	PH29334109	LOCK WASHER 5/16
201	PH29334201	PISTON ROLLER SHAFT (H2933)
201	PH29344201	PISTON ROLLER SHAFT (H2934/G0447)
201	P05814201	PISTON ROLLER SHAFT (G0581)
202	PH29334202	PISTON ROLLER (H2933)
202	PH29344202	PISTON ROLLER (H2934/G0447)
202	P05814202	PISTON ROLLER (G0581)
203	PH29334203	BALL BEARING 6003ZZ

REF	PART #	DESCRIPTION
204	PH29334204	SHAFT BEARING COLLAR
205	PH29334205	SET SCREW 1/4-20 X 1/2
301	PH29334301	GUIDE STUD (H2933/H2934/G0581)
301	P04474301	GUIDE STUD (G0447)
302	PH29334302	PISTON BRACKET MIDDLE
303	PH29334303	ROLL PIN 3 X 27
304	P04474304	RR PISTON BRACKET (G0447)
306	P04474306	LF PISTON BRACKET (G0447)
307	P04474307	L MIDDLE PISTON BRACKET (G0447)
308	P04474308	LR PISTON BRACKET (G0447)
309	PH29334309	LOCK WASHER 5/16
310	PH29334310	HEX BOLT 5/16-18 X 1-1/4
311	P04474311	REAR DEFLECTOR (G0447)
312	P04474312	MIDDLE DEFLECTOR (G0447)
313	P04474313	FRONT DEFLECTOR (G0447)



Sanding Drum and Platen Diagram

5000 Series Parts

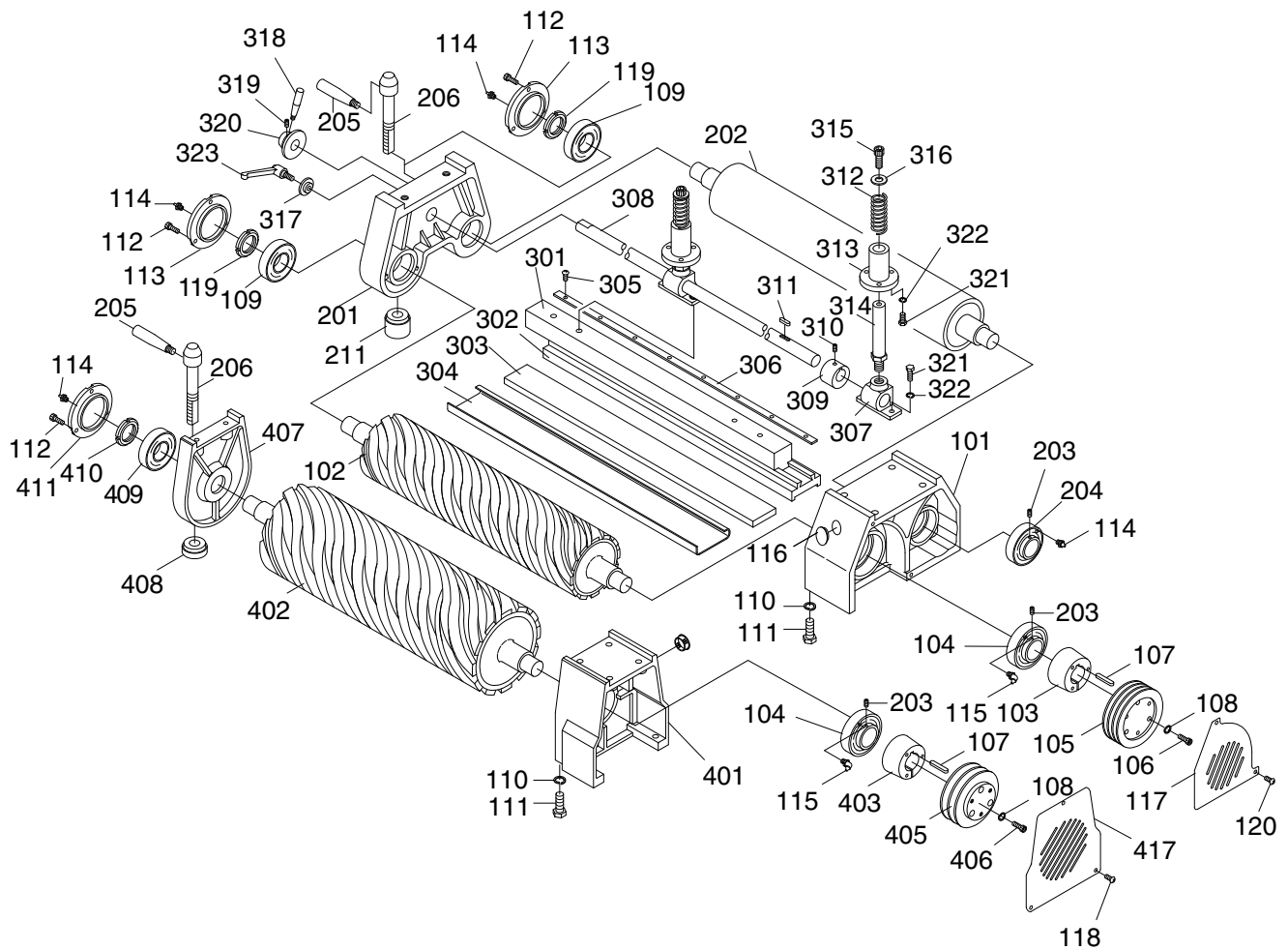

Sanding Drum and Platen Parts List

REF	PART #	DESCRIPTION
101	PH29335101	BEARING HOUSING
102	PH29335102	RUBBER ROLLER (H2933)
102	PH29345102	RUBBER ROLLER (H2934/G0447)
102	P05815102	RUBBER ROLLER (G0581)
103	PH29335103	FASTENING TUBE
104	PH29335104	BEARING UCC206
105	PH29335105	PULLEY
106	PH29335106	CAP SCREW 5/16-18 X 1-1/4
107	PH29335107	KEY 5/16 X 5/16 X 1 3/16
108	PH29335108	LOCK WASHER 5/16
109	PH29335109	BALL BEARING 6205ZZ
110	PH29335110	LOCK WASHER 1/2
111	PH29335111	CAP SCREW 1/2-12 X 1-1/2
112	PH29335112	CAP SCREW 1/4-20 X 1/2
113	PH29335113	BEARING CAP
114	PH29335114	GREASE FITTING W/CAP
115	PH29335115	GREASE FITTING W/CAP
116	PH29335116	PLUG
117	PH29335117	PULLEY COVER
118	PH29335118	PHLP HD SCR 1/4-20 X 1/2
119	PH29335119	SPANNER NUT
120	PH29335120	PHLP HD SCR 1/4-20 X 3/8
201	PH29335201	BEARING HOUSING
202	PH29335202	STEEL ROLLER (H2933)
202	PH29345202	STEEL ROLLER (H2934/G0447)
202	P05815202	STEEL ROLLER (G0581)
203	PH29335203	SPECIAL SET SCREW M6-.75 X 6
204	PH29335204	BEARING UCC205
205	PH29335205	HANDLE
206	PH29335206	SPECIAL SCREW
211	PH29335211	BEARING BRACKET PAD (H2933)
301	PH29335301	25" GRAPHITE BRACKET MALE (H2933)
301	PH29345301	37-1/2" GRAPHITE BRACKET MALE (H2934/G0447)
301	P05815301	44" GRAPHITE BRACKET MALE (G0581)
302	PH29335302	25" GRAPHITE BRACKET FEMALE (H2933)
302	PH29345302	37-1/2" GRAPHITE BRACKET FEMALE (H2934/G0447)
302	P05815302	44" GRAPHITE BRACKET FEMALE (G0581)
303	PH29335303	25" FELT PLATEN PAD (H2933)
303	PH29345303	37-1/2" FELT PLATEN PAD (H2934/G0447)
303	P05815303	44" FELT PLATEN PAD (G0581)

REF	PART #	DESCRIPTION
304	PH29335304	GRAPHITE 25" x 3.54" (H2933)
304	PH29345304	GRAPHITE 37-3/4" x 3.54" (H2934/G0447)
304	P05815304	GRAPHITE 44" x 3.54" (G0581)
305	PH29335305	PHLP HD SCR 10-24 X 1/2
306	PH29335306	25" GRAPHITE PRESSURE PLATE (H2933)
306	PH29345306	37-1/2" GRAPHITE PRESSURE PLATE (H2934/G0447)
306	P05815306	44" GRAPHITE PRESSURE PLATE (G0581)
307	PH29335307	GRAPHITE BRACKET BASE
308	PH29335308	GRAPHITE BRACKET SHAFT (H2933)
308	PH29345308	GRAPHITE BRACKET SHAFT (H2934/G0447)
308	P05815308	GRAPHITE BRACKET SHAFT (G0581)
309	PH29335309	LOCK COLLAR
310	PH29335310	SET SCREW 1/4-20 X 3/8
311	PH29335311	KEY 1/4-20 X 25
312	PH29335312	COMPRESSION SPRING
313	PH29335313	HOUSING
314	PH29335314	GRAPHITE BRACKET SHAFT
315	PH29335315	CAP SCREW 3/8-16 X 3/4
316	PH29335316	FLAT WASHER 3/8
317	PH29335317	FLAT WASHER 3/8
318	PH29335318	HANDLE
319	PH29335319	SET SCREW 5/16-18 X 1/2
320	PH29335320	ADJUSTMENT RING
321	PH29335321	HEX BOLT 5/16-18 X 1
322	PH29335322	FLAT WASHER 5/16
323	PH29335323	HANDLE
401	PH29335401	BEARING HOUSING
402	PH29335402	RUBBER ROLLER (H2933)
402	PH29345402	RUBBER ROLLER (H2934/G0447)
402	P05815402	RUBBER ROLLER (G0581)
403	PH29335403	FASTENING TUBE
405	PH29335405	PULLEY
406	PH29335406	CAP SCREW 5/16-18 X 1-1/4
407	PH29335407	BEARING HOUSING
408	PH29335408	BEARING BRACKET PAD
409	PH29335409	BALL BEARING 6206ZZ
410	PH29335410	SPANNER CAP
411	PH29335411	BEARING CAP
417	PH29335417	PULLEY COVER



Upper Roller System Parts List

REF	PART #	DESCRIPTION
101	PH29336101	SQUARE FRAME REAR (H2933)
101	PH29346101	SQUARE FRAME REAR (H2934)
101	P04476101	SQUARE FRAME REAR (G0447)
101	P05816101	SQUARE FRAME REAR (G0581)
101-1	PH29336101-1	SQUARE FRAME FRONT (H2933)
101-1	PH29346101-1	SQUARE FRAME FRONT (H2934)
101-1	P04476101-1	SQUARE FRAME FRONT (G0447)
101-1	P05816101-1	SQUARE FRAME FRONT (G0581)
103	PH29336103	FRAME SEAL RIGHT (H2933)
103	PH29346103	FRAME SEAL RIGHT (H2934)
103	P04476103	FRAME SEAL RIGHT (G0447)
103	P05816103	FRAME SEAL RIGHT (G0581)
103-1	PH29336103-1	FRAME SEAL FRONT (H2933)
103-1	PH29346103-1	FRAME SEAL FRONT (H2934)
103-1	P04476103-1	FRAME SEAL FRONT (G0447)
103-1	P05816103-1	FRAME SEAL FRONT (G0581)
104	PH29336104	FRAME SEAL LEFT (H2933)
104	PH29346104	FRAME SEAL LEFT (H2934)
104	P04476104	FRAME SEAL LEFT (G0447)
104	P05816104	FRAME SEAL LEFT (G0581)
104-1	PH29336104-1	FRAME SEAL FRNT LFT (H2933)
104-1	PH29346104-1	FRAME SEAL FRNT LFT (H2934)
104-1	P04476104-1	FRAME SEAL FRNT LFT (G0447)
104-1	P05816104-1	FRAME SEAL FRNT LFT (G0581)
105	PH29336105	FLAT HD SCR 1/4-20 X 1/2
106	PH29336106	LOCK WASHER 3/8
107	PH29336107	HEX BOLT 3/8-16 X 1
108	PH29336108	LOCK WASHER 1/2
109	PH29336109	HEX BOLT 1/2-12 X 1
110	PH29336110	PHLP HD SCR 1/4-20 X 1/2
111	PH29336111	CAP SCREW 5/16-18 X 3/4
112	PH29336112	HEX BOLT 5/16-18 X 1
113	PH29336113	AIR CYLINDER
115	PH29336115	LIMIT SWITCH W/CERAMIC TIP
115-1	PH29336115-1	CERAMIC TIP
116	PH29336116	LIMIT SWITCH W/PLASTIC TIP
116-1	PH29336116-1	PLASTIC TIP
116-2	PH29336116-2	LIMIT SWITCH POST
117	PH29336117	LIMIT SWITCH HOLDER
118	PH29336118	AIR SENSOR NOZZLE FEMALE
119	PH29336119	AIR FORK
120	PH29336120	AIR SENSOR NOZZLE MALE
121	PH29336121	THROTTLE VALVE
122	PH29336122	THROTTLE VALVE BASE
123	PH29336123	PLATE
124	PH29336124	HOUSING ASSEMBLY
125	PH29336125	OIL CAP
126	PH29336126	ALUMINUM PLATE

REF	PART #	DESCRIPTION
127	PH29336127	PHLP HD SCR M4-.7 X 12
128	PH29336128	SHUTDOWN BRACKET
129	PH29336129	HEX NUT 3/8-24
130	PH29336130	FLAT WASHER 5/16
131	PH29336131	LOCK WASHER 5/16
132	PH29336132	HEX BOLT 5/16-18 X 1/2
133	PH29336133	PHLP HD SCR 10-24 X 3/4
134	PH29336134	HEX NUT 10-24
135	PH29336135	CONNECTOR OF OIL CAP
136	PH29336136	SHAFT OF OIL CAP
137	P05816137	BRACKET (G0581)
138	P05816138	BRACKET (G0581)
139	PH29336139	CAP SCREW 5/16-18 X 1-1/2
140	PH29336140	CAP SCREW 1/2-12 X 1-1/2
141	PH29336141	LOCK WASHER 1/2
142	PH29336142	HEX BOLT 1/2-12 X 1
201	PH29336201	BRACKET (H2933, H2934, G0447)
201	P05816201	BRACKET (G0581)
202	PH29336202	UPPER ROLLER (H2933)
202	PH29346202	UPPER ROLLER (H2934/G0447)
202	P05816202	UPPER ROLLER (G0581)
203	PH29336203	UPPER ROLLER BRACKET
204	PH29336204	BEARING UCC205
205	PH29336205	SET SCREW M6-1 X 6
206	PH29336206	CAP SCREW 10-24 X 3/4
207	PH29336207	LOCK WASHER 3/8
208	PH29336208	GREASE FITTING W/DUST CAP
301	PH29336301	KNOB (H2933, H2934, G0447)
301	P05816301	KNOB (G0581)
302	PH29336302	ECCENTRIC ROD
303	PH29336303	CAP SCREW 1/2-12 X 3-1/2
304	PH29336304	FLAT WASHER 1/2
305	PH29336305	ECCENTRIC
306	PH29336306	CLEVIS ASSEMBLY
307	PH29336307	EXT RETAINING RING 15MM
308	PH29336308	HEX NUT M10-1.5 (LH)
309	PH29336309	SHAFT OF AIR CYLINDER
310	PH29336310	HEX NUT 1/2-12
311	PH29336311	BOTTOM COVER
312	PH29336312	COMPRESSION SPRING
313	PH29336313	ALUMINUM PLATE
314	PH29336314	FLAT HD SCR M6-1 X 12
315	PH29336315	PLATE
316	PH29336316	TOP COVER
317	PH29336317	HEX NUT 10-24
318	PH29336318	PHLP HD SCR 10-24 X 3/4
319	PH29336319	AIR CYLINDER BASE
320	PH29336320	ECCENTRIC SHAFT FRAME



Cabinet Assembly Diagram

7000 Series Parts

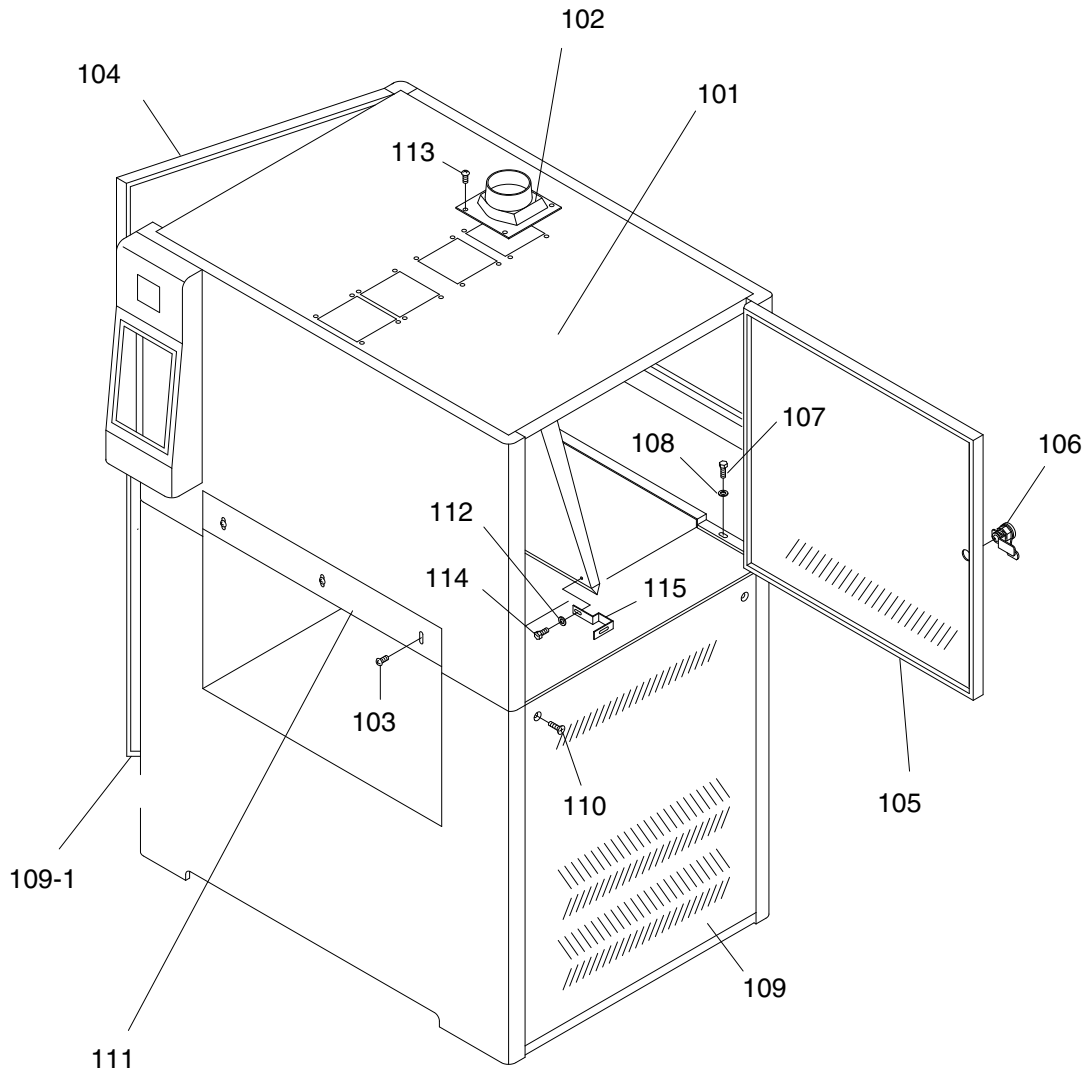

Cabinet Assembly Parts List

REF	PART #	DESCRIPTION
101	PH29337101	UPPER FRAME COVER (H2933)
101	PH29347101	UPPER FRAME COVER (H2934)
101	P04477101	UPPER FRAME COVER (G0447)
101	P05817101	UPPER FRAME COVER (G0581)
102	PH29337102	DUST PORT 4"
103	PH29337103	PHLP HD SCR M6-1 X 12
104	PH29337104	LEFT ACCESS PANEL (H2933)
104	PH29347104	LEFT ACCESS PANEL (H2934)
104	P04477104	LEFT ACCESS PANEL (G0447)
104	P05817104	LEFT ACCESS PANEL (G0581)
105	PH29337105	RIGHT ACCESS PANEL (H2933)
105	PH29347105	RIGHT ACCESS PANEL (H2934)
105	P04477105	RIGHT ACCESS PANEL (G0447)
105	P05817105	RIGHT ACCESS PANEL (G0581)
106	PH29337106	DOOR LOCK
107	PH29337107	HEX BOLT 5/16-18 X 3/4
108	PH29337108	FLAT WASHER 5/16
109	PH29337109	RIGHT DOOR, LOWER FRAME (H2933)
109	PH29347109	RIGHT DOOR, LOWER FRAME (H2934)
109	P04477109	RIGHT DOOR, LOWER FRAME (G0447)

REF	PART #	DESCRIPTION
109	P05817109	RIGHT DOOR, LOWER FRAME (G0581)
109-1	PH29337109-1	LEFT DOOR, LOWER FRAME (H2933)
109-1	PH29347109-1	LEFT DOOR, LOWER FRAME (H2934)
109-1	P04477109-1	LEFT DOOR, LOWER FRAME (G0447)
109-1	P05817109-1	LEFT DOOR, LOWER FRAME (G0581)
110	PH29337110	FLAT HD SCR 1/4-20 X 1/2
111	PH29337111	FRONT PROTECTION PLATE (H2933)
111	PH29347111	FRONT PROTECTION PLATE (H2934)
111	P04477111	FRONT PROTECTION PLATE (G0447)
111	P05817111	FRONT PROTECTION PLATE (G0581)
112	PH29337112	FLAT WASHER 1/4
113	PH29337113	PHLP HD SCR M6-1 X 12
114	PH29337114	HEX BOLT 1/4-20 X 3/4
115	PH29337115	STANDOFF BRACKET



Main Electrical Panel and Controls Diagram

8000 Series Parts

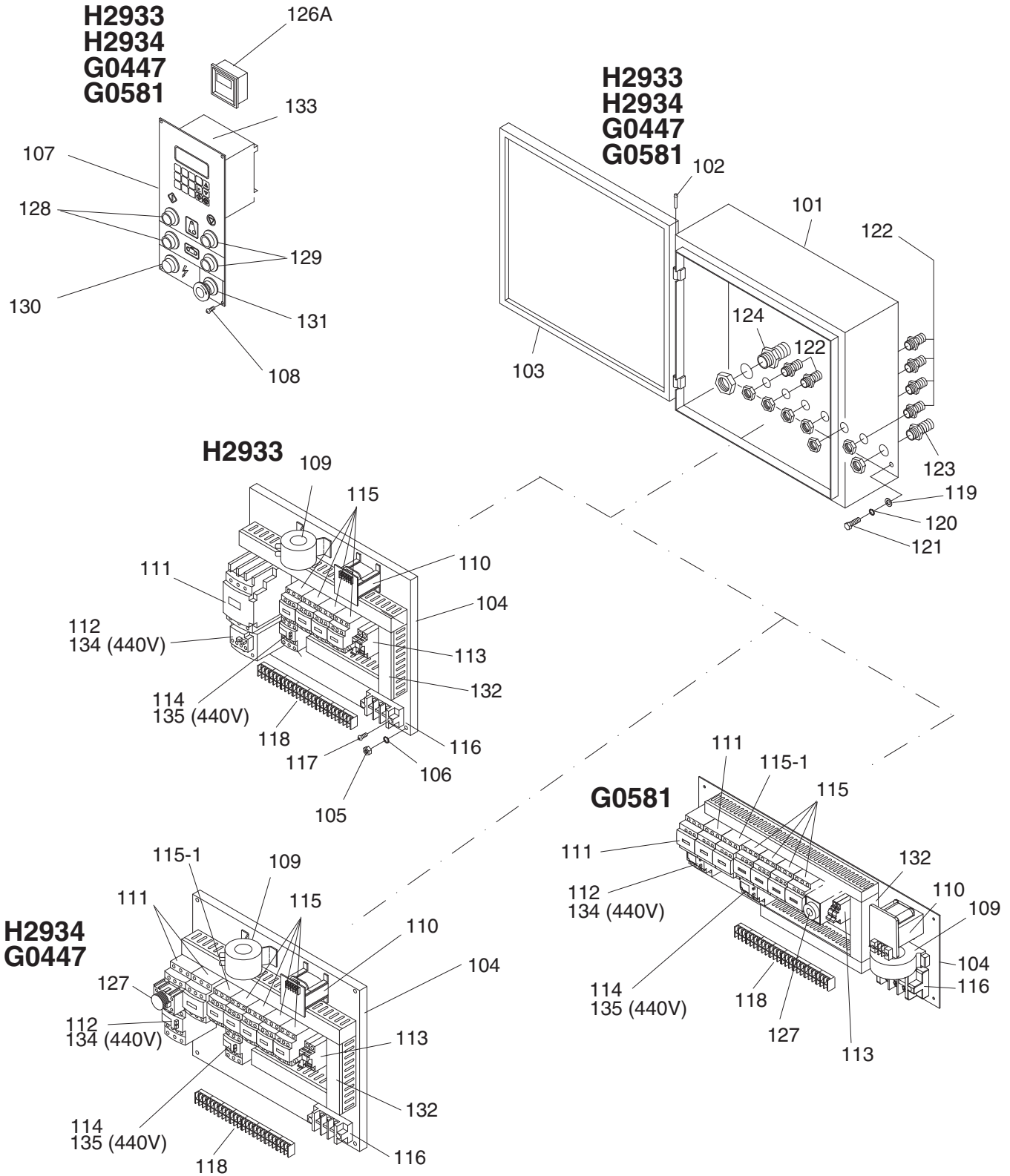

Main Electrical Panel and Controls Parts List

REF	PART #	DESCRIPTION
101	PH29338101	ELECTRICAL CONTROL BOX (H2933)
101	PH29348101	ELECTRICAL CONTROL BOX (H2934/G0447)
101	P05818101	ELECTRICAL CONTROL BOX (G0581)
102	PH29338102	HINGE
103	PH29338103	DOOR (H2933)
103	PH29348103	DOOR (H2934/G0447)
103	P05818103	DOOR (G0581)
104	PH29338104	BASE PLATE (H2933)
104	PH29348104	BASE PLATE (H2934/G0447)
104	P05818104	BASE PLATE (G0581)
105	PH29338105	HEX NUT 1/4-20
106	PH29338106	LOCK WASHER 1/4
107	PH29338107	CONTROL PANEL
108	PH29338108	PHLP HD SCR M4-.7 X 8
109	PH29338109	CURRENT SENSOR
110	PH29338110	TRANSFORMER
111	PH29338111	CONTACTOR LC1-D40 (H2933)
111	PH29348111	CONTACTOR LC1-D368 (H2934/G0447/G0581)
112	PH29338112	RELAY LR3-D3355 220V (30-40A)(H2933)
112	PH29348112	RELAY LR3-D326 220V (23-32A) (H2934/G0447)
112	P05818112	RELAY LR3D-D356 220V (30-38A) (G0581)
113	PH29338113	FUSE TE10.3 X 38 & 500V/4Ax2
114	PH29338114	RELAY LR3-086 220V (2.5-4A) (H2933/H2934/G0447)

REF	PART #	DESCRIPTION
114	P05818114	RELAY LR3D-126 220V (2.5-4A) (G0581)
115	PH29338115	CONTACTOR LC1-D096 (H2933)
115-1	PH29348115-1	CONTACTOR LC1-D256 (H2934/G0447)
115-1	P05818115-1	CONTACTOR LC1-D098 (G0581)
116	PH29338116	POWER WIRE TERMINAL (H2933)
116	PH29348116	POWER WIRE TERMINAL (H2934/G0447)
116	P05818116	POWER WIRE TERMINAL (G0581)
118	PH29338118	TERMINAL PLATE
119	PH29338119	FLAT WASHER 1/4
120	PH29338120	LOCK WASHER 1/4
121	PH29338121	HEX BOLT 1/4-20 X 1/2
122	PH29338122	PU CONNECTOR 1/2"
123	PH29338123	PU CONNECTOR 3/4"
124	PH29338124	CABLE CONNECTOR 1"
126A	PH29338126A	DIGITAL AMP METER N/S
127	PH29348127	START DELAY LADS2 (H2934/G0447)
127	P05818127	START DELAY TRD-N (STON BRAND) (G0581)
128	PH29338128	START SWITCH
129	PH29338129	STOP SWITCH
130	PH29338130	POWER INDICATION LIGHT
131	PH29338131	EMERGENCY STOP SWITCH
132	PH29338132	WIRE COLUMN (G0581)
132	P05818132	WIRE COLUMN (H2933/H2934/G0447)
133	PH29338133	COMPUTER

G0447 440V Conversion Kit

139	PH29349139	440V CONVERSION KIT
134	PH29348134	OL RELAY SCHN LR3D21 12-18A
135	PH29338135	OL RELAY SCHN LR3D07 1.6-2.5A

H2933 440V Conversion Kit

139V2	PH29339139V	440V CONVERSION KIT
134V2	PH29338134V	OL RELAY SCHN LR3D325 17-25A V2.04.13
135	PH29338135	OL RELAY SCHN LR3D07 1.6-2.5A

G0581 440V Conversion Kit

139	P05819139	440V CONVERSION KIT
134	PH29348134	OL RELAY SCHN LR3D21 12-18A
135	PH29338114	OL RELAY SCHN LR3D08 2.5-4A

H2934 440V Conversion Kit

139	PH29349139	440V CONVERSION KIT
134	PH29348134	OL RELAY SCHN LR3D21 12-18A
135	PH29338135	OL RELAY SCHN LR3D07 1.6-2.5A



Belt Oscillation System Diagram

9000 Series Parts

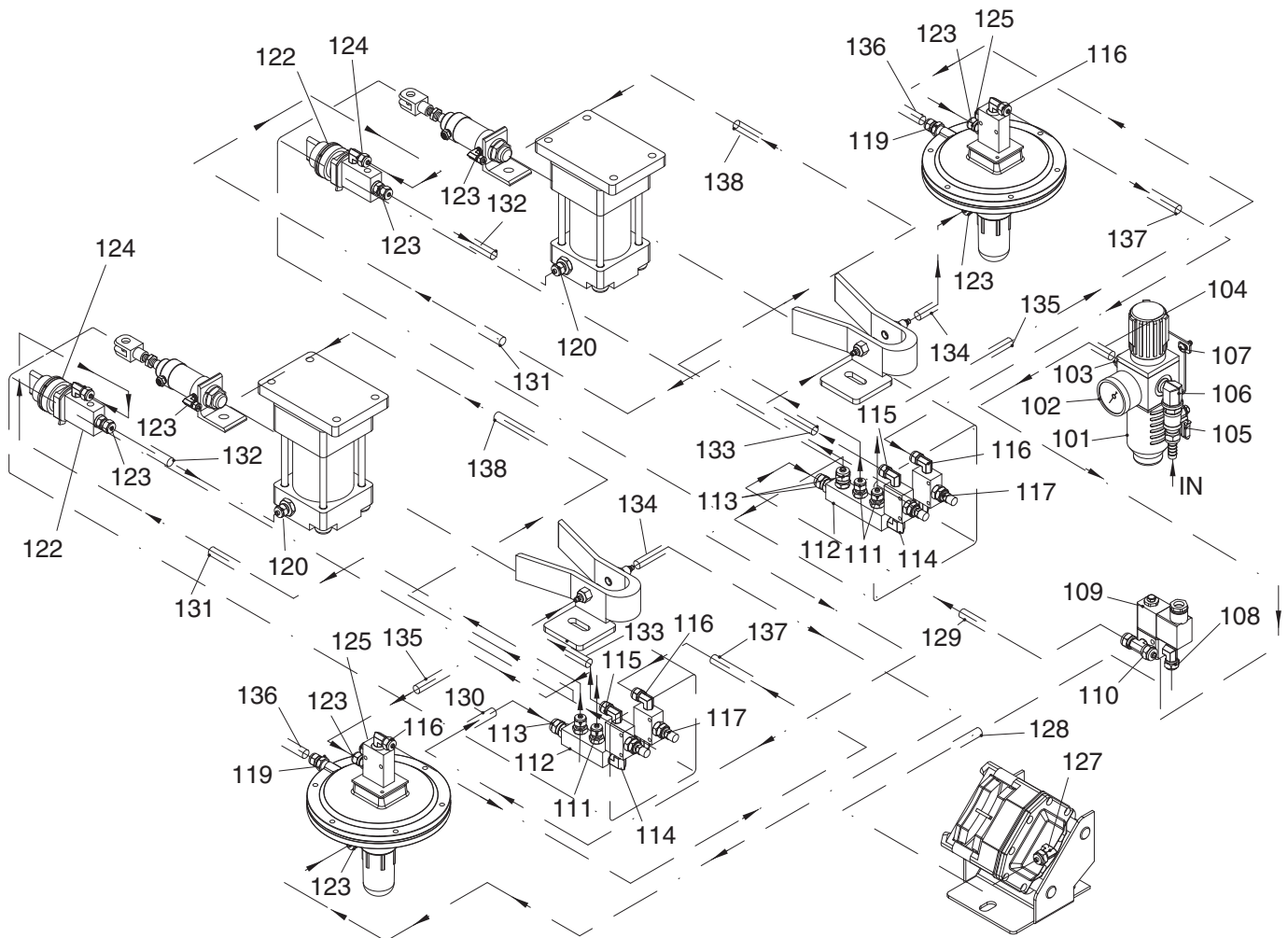

Belt Oscillation System Parts List

REF	PART #	DESCRIPTION
101	PH29339101	FILTER CUP
102	PH29339102	REGULATOR W/GAUGE
103	PH29339103	BRONZE CONNECTOR
104	PH29339104	FLEXIBLE HOSE
105	PH29339105	AIR SWITCH
106	PH29339106	ELBOW
107	PH29339107	PHLP HD SCR 10-24 x 5/8
108	PH29339108	ELBOW 5/16N X 1/8T 90°
109	PH29339109	SOLENOID VALVE
110	PH29339110	T-FITTING 5/16N X 5/16N X 1/8T
111	PH29339111	CONNECTOR
112	PH29339112	MANIFOLD 1/4N 2-PORT
113	PH29339113	CONNECTOR 5/16N X 1/8T
114	PH29339114	ELBOW 1/4N X 1/4N 90°
115	PH29339115	CONNECTOR 1/4N X 1/8T 90°
116	PH29339116	CONNECTOR 1/4N X 1/8T 90°
117	PH29339117	THROTTLE VALVE
119	PH29339119	CONNECTOR 1/4N X 1/8T

REF	PART #	DESCRIPTION
120	PH29339120	CONNECTOR 3/8N X 1/8T
121	PH29339121	CONNECTOR 1/4N X 1/8T
122	PH29339122	AIR SWITCH
123	PH29339123	CONNECTOR 1/4N X 1/8T
124	PH29339124	CONNECTOR 1/4N X 1/8T 90°
125	PH29339125	BUFFER
127	PH29339127	CONNECTOR 5/16N X 1/8T 90°
128	PH29339128	8MM FLEXIBLE HOSE
129	PH29339129	6MM FLEXIBLE HOSE
131	PH29339131	6MM FLEXIBLE HOSE
132	PH29339132	6MM FLEXIBLE HOSE
133	PH29339133	6MM FLEXIBLE HOSE
134	PH29339134	6MM FLEXIBLE HOSE
135	PH29339135	6MM FLEXIBLE HOSE
136	PH29339136	6MM FLEXIBLE HOSE
137	PH29339137	6MM FLEXIBLE HOSE
138	PH29339138	6MM FLEXIBLE HOSE



Machine Label Diagram

9000 Series Parts

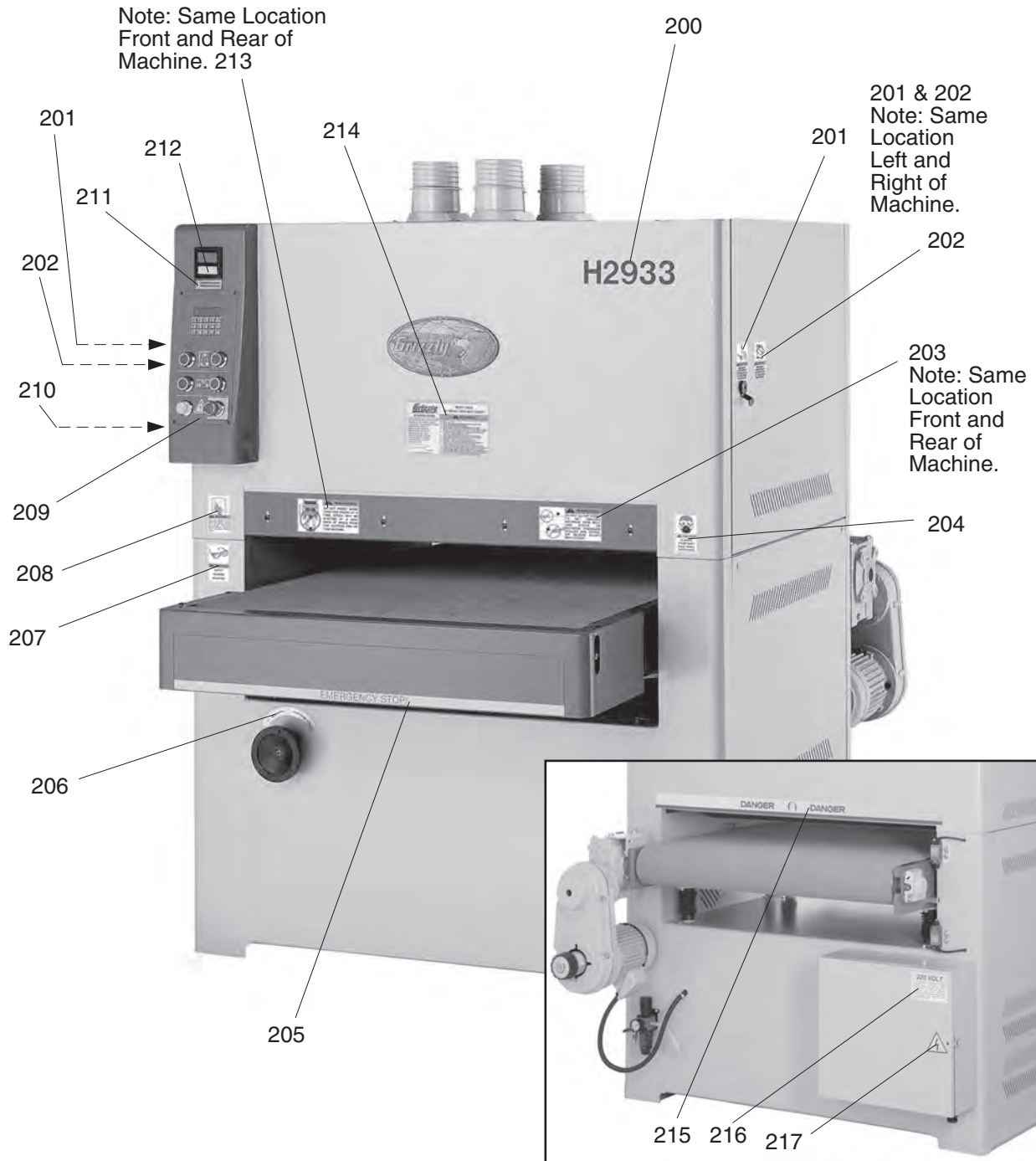

! WARNING

Safety labels warn about machine hazards and ways to prevent injury. The owner of this machine **MUST** maintain the original location and readability of the labels on the machine. If any label is removed or becomes unreadable, **REPLACE** that label before using the machine again. Contact Grizzly at (800) 523-4777 or www.grizzly.com to order new labels.



Machine Label List

REF	PART #	DESCRIPTION
200	PH29339200	LABEL, MODEL H2933
200	PH29349200	LABEL, MODEL H2934
200	P04479200	LABEL, MODEL G0447
200	P05819200	LABEL, MODEL G0581
201	PH29339201	LABEL, UNPLUG SANDER
202	PH29339202	LABEL, DOOR CLOSED
203	PH29339203	LABEL, HAND PINCH IN BELT
204	PH29339204	LABEL, DUST MASK
205	PH29339205	LABEL, EMERGENCY STRIPE
206	PH29339206	LABEL, ROTATION LABEL
207	PH29339207	LABEL, SAFETY GLASSES
208	PH29339208	LABEL, READ MANUAL
209	PH29339209	LABEL, CONTROL PANEL FACE
210	PH29339210	LABEL, CONVERSION CHART

REF	PART #	DESCRIPTION
211	PH29339211	LABEL, H2933 AMP SCALE
211	PH29349211	LABEL, H2934 AMP SCALE
211	P04479211	LABEL, G0447 AMP SCALE
211	P05819211	LABEL, G0581 AMP SCALE
212	P02933212	LABEL, G0581 AMP SCALE
213	P02933213	LABEL, G0581 AMP SCALE
214	PH2933214	LABEL, G0581 AMP SCALE
214	PH29349214	LABEL, G0581 AMP SCALE
214	P04479214	LABEL, G0581 AMP SCALE
214	P05819214	LABEL, G0581 AMP SCALE
215	PH29339215	LABEL, G0581 AMP SCALE
216	PH29339216	LABEL, G0581 AMP SCALE
217	PH29339217	LABEL, G0581 AMP SCALE

