

# ***Grizzly*** ***Industrial, Inc.***®

## **MODEL T21318** **36" SLIP ROLL 22 GAUGE** **OWNER'S MANUAL** *(FOR MACHINES MANUFACTURED AFTER 1/09)*



COPYRIGHT © MARCH, 2009 BY GRIZZLY INDUSTRIAL, INC.  
**WARNING: NO PORTION OF THIS MANUAL MAY BE REPRODUCED IN ANY SHAPE  
OR FORM WITHOUT THE WRITTEN APPROVAL OF GRIZZLY INDUSTRIAL, INC.**  
#JB11594 PRINTED IN CHINA

 **WARNING!**

**This manual provides critical safety instructions on the proper setup, operation, maintenance and service of this machine/equipment.**

**Failure to read, understand and follow the instructions given in this manual may result in serious personal injury, including amputation, electrocution or death.**

**The owner of this machine/equipment is solely responsible for its safe use. This responsibility includes but is not limited to proper installation in a safe environment, personnel training and usage authorization, proper inspection and maintenance, manual availability and comprehension, application of safety devices, blade/cutter integrity, and the usage of personal protective equipment.**

**The manufacturer will not be held liable for injury or property damage from negligence, improper training, machine modifications or misuse.**

 **WARNING!**

**Some dust created by power sanding, sawing, grinding, drilling, and other construction activities contains chemicals known to the State of California to cause cancer, birth defects or other reproductive harm. Some examples of these chemicals are:**

- **Lead from lead-based paints.**
- **Crystalline silica from bricks, cement and other masonry products.**
- **Arsenic and chromium from chemically-treated lumber.**

**Your risk from these exposures varies, depending on how often you do this type of work. To reduce your exposure to these chemicals: Work in a well ventilated area, and work with approved safety equipment, such as those dust masks that are specially designed to filter out microscopic particles.**

# Table of Contents

- INTRODUCTION..... 2**
  - Manual Accuracy..... 2
  - Contact Info..... 2
  - Functional Overview..... 2
  - Identification..... 3
  - Machine Data Sheet..... 4
  
- SECTION 1: SAFETY..... 5**
  - Safety Instructions for Machinery..... 5
  - Additional Safety for Slip Rolls..... 7
  
- SECTION 2: SETUP..... 8**
  - Items Needed for Setup..... 8
  - Unpacking..... 8
  - Inventory..... 9
  - Hardware Recognition Chart..... 10
  - Clean Up..... 11
  - Site Considerations..... 11
  - Assembly..... 12
  - Mounting..... 12
  
- SECTION 3: OPERATIONS..... 13**
  - Basic Controls..... 13
  - Preparation..... 14
  - Flat Rolling..... 14
  - Creating Bends..... 15
  - Creating Cylinders..... 17
  - Bending Wire..... 19
  - Removing Workpiece..... 20
  
- SECTION 4: ACCESSORIES..... 21**
  
- SECTION 5: MAINTENANCE..... 23**
  - Schedule..... 23
  - Cleaning..... 23
  - Unpainted Cast Iron..... 23
  - Lubrication..... 23
  
- SECTION 6: SERVICE..... 24**
  - Troubleshooting..... 24
  - Parts Breakdown & List..... 25
  - Labels Breakdown & Parts List..... 26
  
- WARRANTY AND RETURNS..... 29**

# INTRODUCTION

## Manual Accuracy

We are proud to offer this manual with your new machine! We've made every effort to be exact with the instructions, specifications, drawings, and photographs of the machine we used when writing this manual. However, sometimes errors do happen and we apologize for them.

Also, owing to our policy of continuous improvement, **your machine may not exactly match the manual**. If you find this to be the case, and the difference between the manual and machine leaves you in doubt, check our website for the latest manual update or call technical support for help.

Before calling, find the manufacture date of your machine by looking at the date stamped into the machine ID label (see below). This will help us determine if the manual version you received matches the manufacture date of your machine.

		MODEL GXXXX MACHINE NAME	
SPECIFICATIONS		▲ WARNING!	
Motor:		<b>Manufacture Date of Your Machine</b> ing this machine: operation. s and respirator. sted/setup and suit before starting.	
Specification:			
Specification:			
Specification:			
Weight:			
<input type="text"/>	Date	<ol style="list-style-type: none"><li>4. Make sure the motor has stopped and disconnect power before adjustments, maintenance, or service.</li><li>5. DO NOT expose to rain or dampness.</li><li>6. DO NOT modify this machine in any way.</li><li>7. DO NOT remove safety guards.</li><li>8. Never leave machine running unattended.</li><li>9. DO NOT operate under the influence of drugs or alcohol.</li><li>10. Maintain machine carefully to prevent accidents.</li></ol>	
<input type="text"/>	Serial Number		
Manufactured for Grizzly in Taiwan			

For your convenience, we post all available manuals and manual updates for free on our website at [www.grizzly.com](http://www.grizzly.com). Any updates to your model of machine will be reflected in these documents as soon as they are complete.

## Contact Info

We stand behind our machines. If you have any service questions, parts requests or general questions about the machine, please call or write us at the location listed below.

Grizzly Industrial, Inc.  
1203 Lycoming Mall Circle  
Muncy, PA 17756  
Phone: (570) 546-9663  
Fax: (800) 438-5901  
E-Mail: [techsupport@grizzly.com](mailto:techsupport@grizzly.com)

If you have any comments regarding this manual, please write to us at the address below:

Grizzly Industrial, Inc.  
c/o Technical Documentation Manager  
P.O. Box 2069  
Bellingham, WA 98227-2069  
Email: [manuals@grizzly.com](mailto:manuals@grizzly.com)

## Machine Description

A slip roll is a sheet-metal working machine used to create constant-radius curves in workpieces. The three roller system allows an operator to create cylinders, cones, and bends.

The T21318 features a quick-release system for releasing cylindrical workpieces from the machine.



# Identification

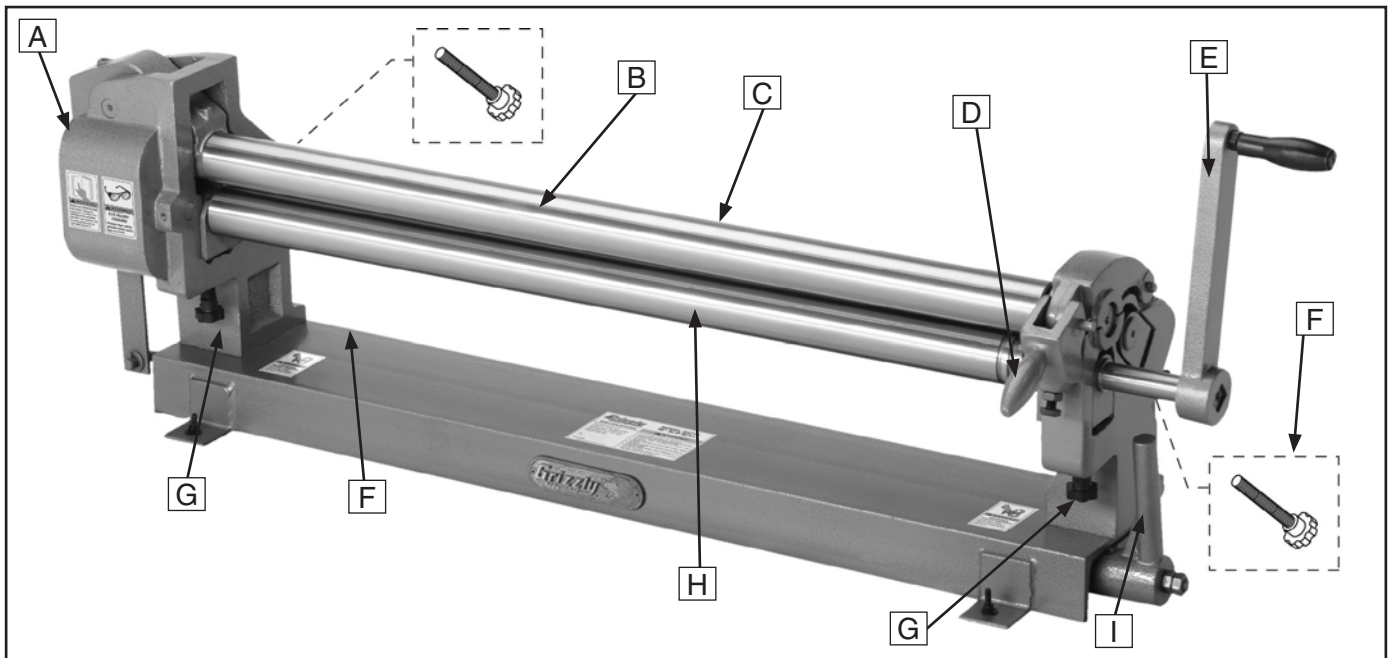

Figure 1. Identification.

## Identification List (Figures 1 and 2)

- A. Gear Assembly Cover
- B. Top Roller
- C. Rear Roller
- D. Top Roller Release Lever
- E. Crank
- F. Radius Adjustment Knob
- G. Thickness Adjustment Knob
- H. Bottom Roller
- I. Top Roller Lift Lever

## Sample Illustration (Figure 2)

Throughout this manual, diagrams are used to illustrate how the components of the machine are used during the various steps of operation.

Familiarize yourself with the following illustration, its relationship to the machine, and the symbols used in it before proceeding through this manual.

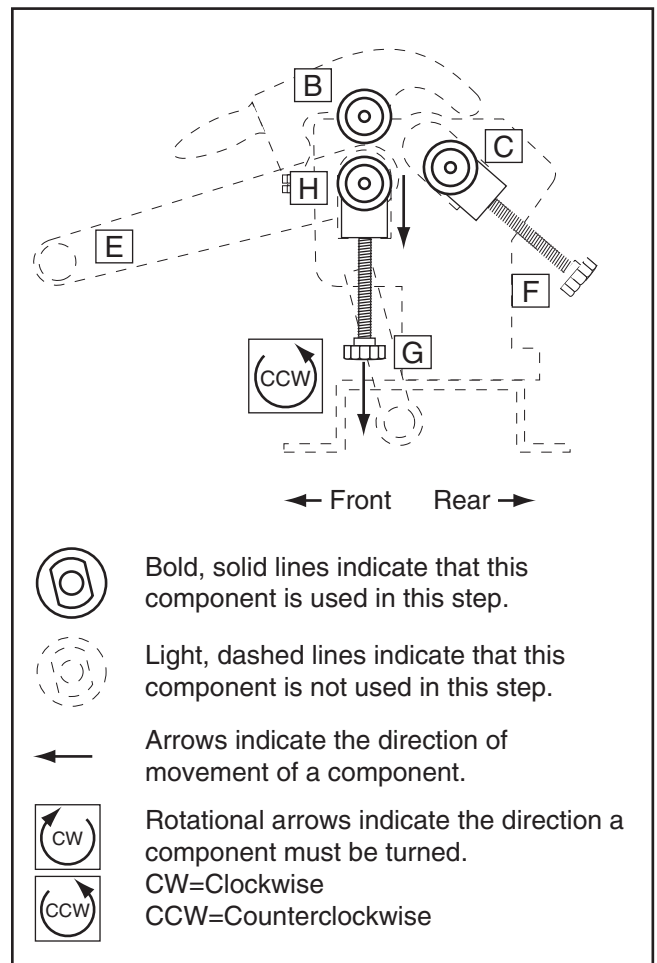

Figure 2. Sample illustration.





# MACHINE DATA SHEET

Customer Service #: (570) 546-9663 • To Order Call: (800) 523-4777 • Fax #: (800) 438-5901

## MODEL T21318 36" SLIP ROLL

### Product Dimensions:

Width/Depth/Height .....49" x 17" x 15"  
 Footprint (Width/Depth)..... 42" x 10½"  
 Weight..... 265lbs.

### Shipping Dimensions:

Type ..... Crate  
 Content..... Machine  
 Weight..... 280 lbs.  
 Width/Depth/Height..... 53" x 18" x 22"

### Main Specifications:

#### Capacities

Minimum Roll Diameter ..... 2"  
 Maximum Gauge ..... .22 ga. Mild Steel  
 Wire Sizes ..... 3/16", 1/4", 5/16"  
 Maximum Capacity ..... 36"

#### Construction

Rollers ..... Precision-Ground Steel  
 Frame ..... Welded Steel  
 Head and Tail Supports ..... Cast Iron

### Other Specifications:

Country Of Origin ..... China  
 Warranty..... 1 Year  
 Serial Number Location ..... ID Label on Base

### Features:

Quick Release Top Roller  
 Hardened Steel Gearing



# SECTION 1: SAFETY

## WARNING

### For Your Own Safety, Read Instruction Manual Before Operating this Machine

The purpose of safety symbols is to attract your attention to possible hazardous conditions. This manual uses a series of symbols and signal words intended to convey the level of importance of the safety messages. The progression of symbols is described below. Remember that safety messages by themselves do not eliminate danger and are not a substitute for proper accident prevention measures.



Indicates an imminently hazardous situation which, if not avoided, **WILL** result in death or serious injury.



Indicates a potentially hazardous situation which, if not avoided, **COULD** result in death or serious injury.



Indicates a potentially hazardous situation which, if not avoided, **MAY** result in minor or moderate injury. It may also be used to alert against unsafe practices.

**NOTICE**

This symbol is used to alert the user to useful information about proper operation of the machine.

## WARNING

### Safety Instructions for Machinery

- 1. READ THE ENTIRE MANUAL BEFORE STARTING MACHINERY.** Machinery presents serious injury hazards to untrained users.
- 2. ALWAYS USE ANSI APPROVED SAFETY GLASSES WHEN OPERATING MACHINERY.** Everyday eyeglasses only have impact resistant lenses—they are NOT safety glasses.
- 3. ALWAYS WEAR A NIOSH APPROVED RESPIRATOR WHEN OPERATING MACHINERY THAT PRODUCES DUST.** Most types of dust (wood, metal, etc.) can cause severe respiratory illnesses.
- 4. ALWAYS USE HEARING PROTECTION WHEN OPERATING MACHINERY.** Machinery noise can cause permanent hearing loss.
- 5. WEAR PROPER APPAREL. DO NOT** wear loose clothing, gloves, neckties, rings, or jewelry that can catch in moving parts. Wear protective hair covering to contain long hair and wear non-slip footwear.
- 6. NEVER OPERATE MACHINERY WHEN TIRED OR UNDER THE INFLUENCE OF DRUGS OR ALCOHOL.** Be mentally alert at all times when running machinery.



# WARNING

## Safety Instructions for Machinery

7. **ONLY ALLOW TRAINED AND PROPERLY SUPERVISED PERSONNEL TO OPERATE MACHINERY.** Make sure operation instructions are safe and clearly understood.
8. **KEEP CHILDREN AND VISITORS AWAY.** Keep all children and visitors a safe distance from the work area.
9. **MAKE WORKSHOP CHILDPROOF.** Use padlocks, master switches, and remove start switch keys.
10. **NEVER LEAVE WHEN MACHINE IS RUNNING.** Turn power **OFF** and allow all moving parts to come to a complete stop before leaving machine unattended.
11. **DO NOT USE IN DANGEROUS ENVIRONMENTS.** DO NOT use machinery in damp, wet locations, or where any flammable or noxious fumes may exist.
12. **KEEP WORK AREA CLEAN AND WELL LIGHTED.** Clutter and dark shadows may cause accidents.
13. **USE A GROUNDED EXTENSION CORD RATED FOR THE MACHINE AMPERAGE.** Grounded cords minimize shock hazards. Undersized cords create excessive heat. Always replace damaged extension cords.
14. **ALWAYS DISCONNECT FROM POWER SOURCE BEFORE SERVICING MACHINERY.** Make sure switch is in OFF position before reconnecting.
15. **MAINTAIN MACHINERY WITH CARE.** Keep blades sharp and clean for best and safest performance. Follow instructions for lubricating and changing accessories.
16. **MAKE SURE GUARDS ARE IN PLACE AND WORK CORRECTLY BEFORE USING MACHINERY.**
17. **REMOVE ADJUSTING KEYS AND WRENCHES.** Make a habit of checking for keys and adjusting wrenches before turning machinery **ON**.
18. **CHECK FOR DAMAGED PARTS BEFORE USING MACHINERY.** Check for binding or misaligned parts, broken parts, loose bolts, and any other conditions that may impair machine operation. Repair or replace damaged parts before operation.
19. **USE RECOMMENDED ACCESSORIES.** Refer to the instruction manual for recommended accessories. Improper accessories increase risk of injury.
20. **DO NOT FORCE MACHINERY.** Work at the speed for which the machine or accessory was designed.
21. **SECURE WORKPIECE.** Use clamps or a vise to hold the workpiece when practical. A secured workpiece protects your hands and frees both hands to operate the machine.
22. **DO NOT OVERREACH.** Maintain stability and balance at all times.
23. **MANY MACHINES CAN EJECT WORKPIECES TOWARD OPERATOR.** Know and avoid conditions that cause the workpiece to "kickback."
24. **ALWAYS LOCK MOBILE BASES (IF USED) BEFORE OPERATING MACHINERY.**
25. **CERTAIN DUST MAY BE HAZARDOUS** to the respiratory systems of people and animals, especially fine dust. Be aware of the type of dust you are exposed to and always wear a respirator designed to filter that type of dust.



# **WARNING**

## **Additional Safety for Slip Rolls**

- 1. METAL EDGES.** Always de-burr sharp metal edges before inserting them into the slip roll. Sharp edges on sheet metal can cause severe cuts.
- 2. HAND PROTECTION.** Always wear leather gloves when using this tool.
- 3. PINCHING HAZARD.** Keep fingers out of roller path during operation.
- 4. CRUSHING HAZARD.** Make sure rollers and workpieces are fully supported during installation and removal. Wear steel toed footwear during operation to protect your feet if you drop a roller or workpiece.
- 5. EXPERIENCING DIFFICULTIES.** If at any time you are experiencing difficulties performing the intended operation, stop using the machine! Contact Tech Support at (570) 546-9663.

### **WARNING**

Like all machinery there is potential danger when operating this machine. Accidents are frequently caused by lack of familiarity or failure to pay attention. Use this machine with respect and caution to lessen the possibility of operator injury. If normal safety precautions are overlooked or ignored, serious personal injury may occur.

### **CAUTION**

No list of safety guidelines can be complete. Every shop environment is different. Always consider safety first, as it applies to your individual working conditions. Use this and other machinery with caution and respect. Failure to do so could result in serious personal injury, damage to equipment, or poor work results.



# SECTION 2: SETUP

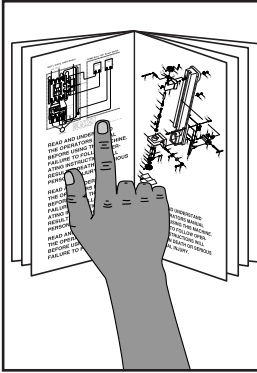

## **!WARNING**

This machine presents serious injury hazards to untrained users. Read through this entire manual to become familiar with the controls and operations before starting the machine!

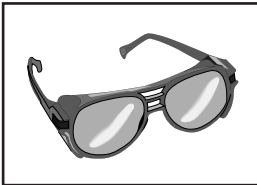

## **!WARNING**

Wear safety glasses during the entire setup process!

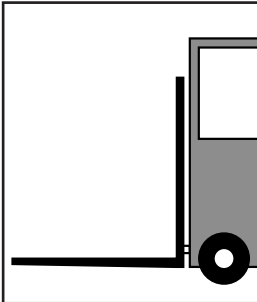

## **!WARNING**

This machine and its components are very heavy. Get lifting help or use power lifting equipment such as a forklift to move heavy items.

## Items Needed for Setup

The following items are needed to complete the setup process, but are not included with your machine:

Description	Qty
• Power Lifting Equipment (Rated for at least 300 lbs) .....	1
• Lifting Straps (Rated for at least 300 lbs.) .....	2
• Assistants .....	As needed
• Safety Glasses (For each assistant) .....	1

## Unpacking

Your machine was carefully packaged for safe transportation. Remove the packaging materials from around your machine and inspect it. If you discover the machine is damaged, *please immediately call Customer Service at (570) 546-9663 for advice.*

Save the containers and all packing materials for possible inspection by the carrier or its agent. *Otherwise, filing a freight claim can be difficult.*

When you are completely satisfied with the condition of your shipment, inventory the contents.



# Inventory

The following is a description of the main components shipped with your machine. Lay the components out to inventory them.

**Note:** *If you can't find an item on this list, check the mounting location on the machine or examine the packaging materials carefully. Occasionally we pre-install certain components for shipping purposes.*

Box 1: (Figure 3)	Qty
A. Slip Roll .....	1
B. Crank Handle .....	1
C. Crank.....	1
D. Hex Bolt M8-1.25 x 40.....	1

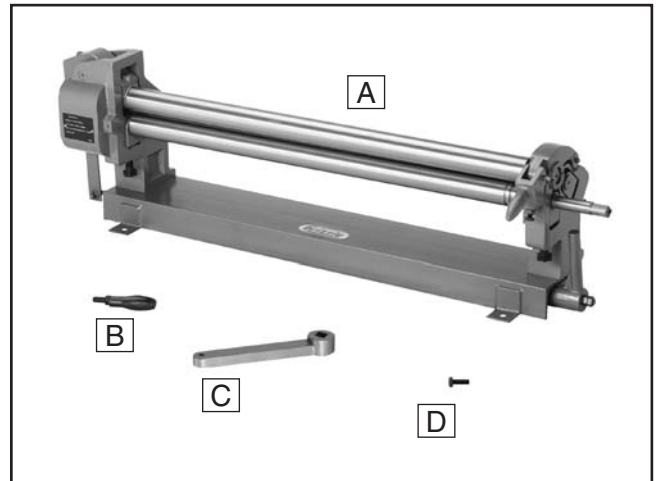

**Figure 3.** Inventory.

If any nonproprietary parts are missing (e.g. a nut or a washer), we will gladly replace them; or for the sake of expediency, replacements can be obtained at your local hardware store.



# Hardware Recognition Chart

USE THIS CHART TO MATCH UP HARDWARE DURING THE ASSEMBLY PROCESS.

MEASURE BOLT DIAMETER BY PLACING INSIDE CIRCLE

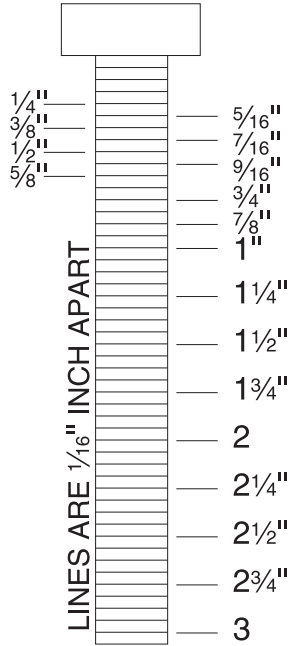
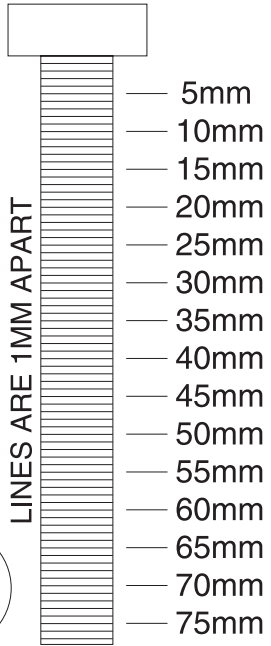
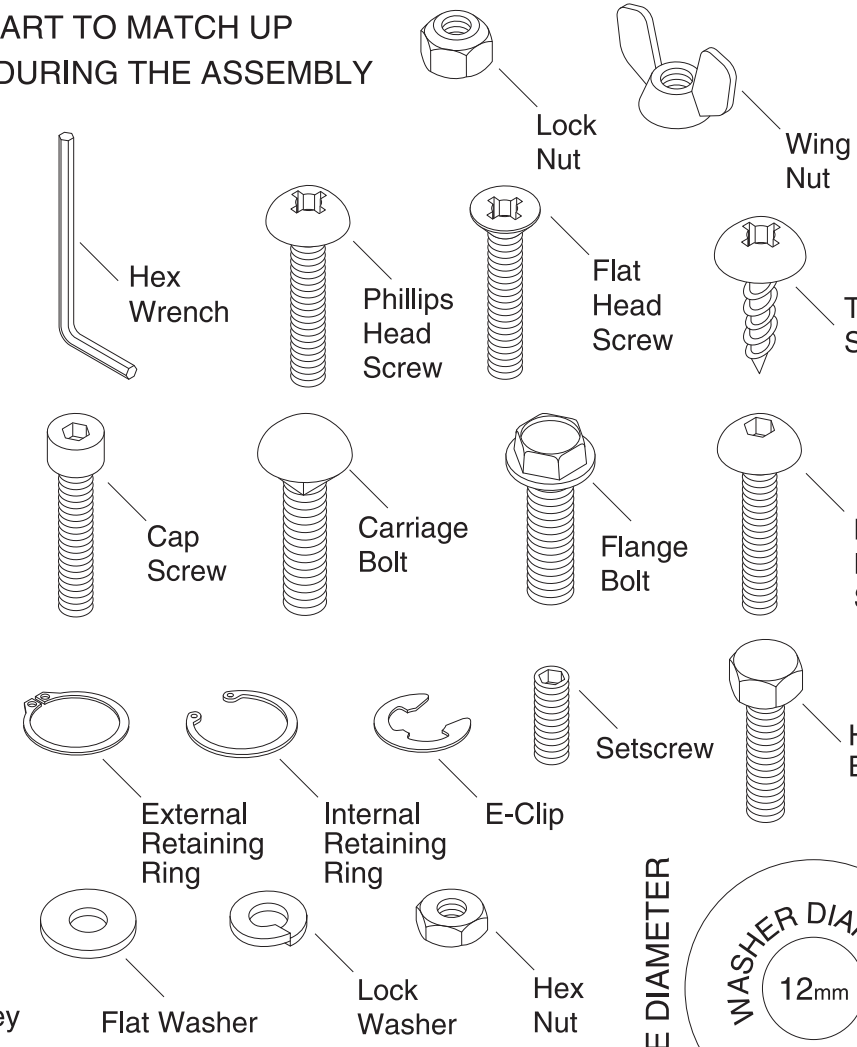
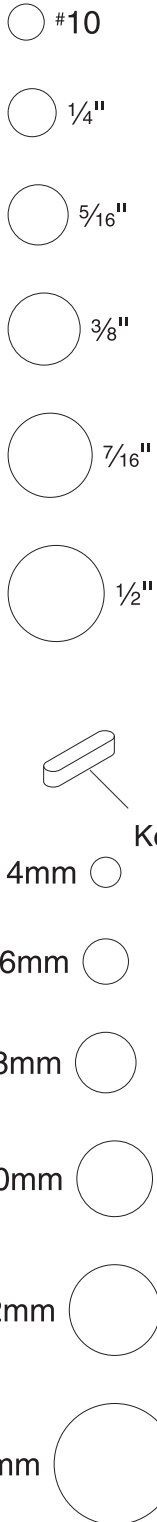

WASHERS ARE MEASURED BY THE INSIDE DIAMETER

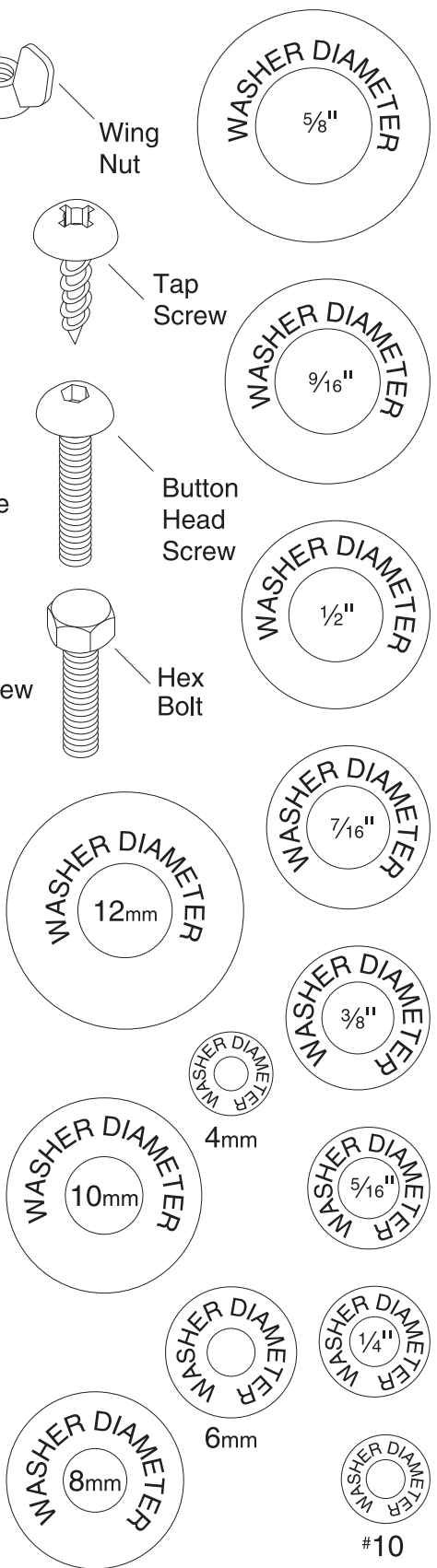

# Clean Up

The unpainted surfaces are coated with a waxy oil to prevent corrosion during shipment. Remove this protective coating with a solvent cleaner or degreaser, such as shown in **Figure 4**. For thorough cleaning, some parts must be removed. **For optimum performance, clean all moving parts or sliding contact surfaces.** Avoid chlorine-based solvents, such as acetone or brake parts cleaner that may damage painted surfaces. Always follow the manufacturer's instructions when using any type of cleaning product.

	<p><b>! WARNING</b> Gasoline and petroleum products have low flash points and can explode or cause fire if used to clean machinery. <b>DO NOT</b> use these products to clean the machinery.</p>
---	--

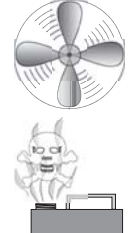
	<p><b>! CAUTION</b> Many cleaning solvents are toxic if inhaled. Minimize your risk by only using these products in a well ventilated area.</p>
---	---

**G2544—Solvent Cleaner & Degreaser**  
**H9692—Orange Power Degreaser**  
 Great products for removing shipping grease.



**Figure 4.** Cleaner/degreasers available from Grizzly.

# Site Considerations

## Floor Load

Refer to the **Machine Data Sheet** for the weight and footprint specifications of your machine. Some workbenches may require additional reinforcement to support both the machine and workpiece.

## Placement Location

Consider existing and anticipated needs, size of material to be processed through each machine, and space for auxiliary stands, work tables or other machinery when establishing a location for your new machine. See **Figure 5** for the minimum working clearances.

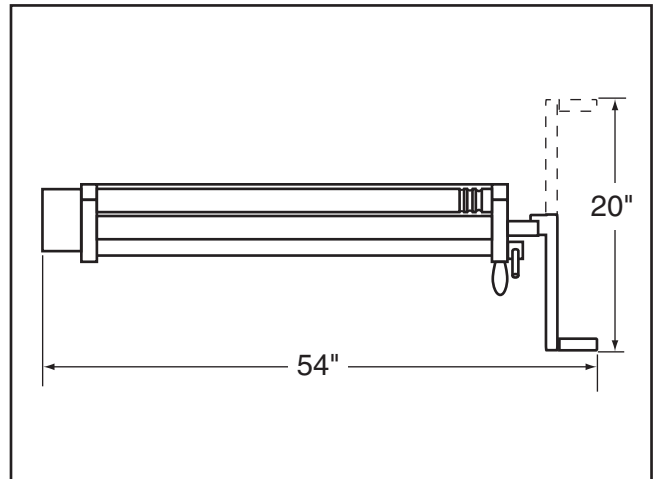

**Figure 5.** Minimum working clearances.

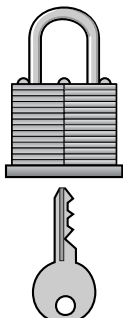
	<p><b>! CAUTION</b> Children and visitors may be seriously injured if unsupervised around this machine. Lock entrances to the shop or disable start switch or power connection to prevent unsupervised use.</p>
--	---



# Assembly

The Model T21318 comes from the factory almost fully assembled. All that is required to assemble are the crank and handle.

## To assemble your machine:

1. Thread the crank handle into the small end of the crank and tighten, as shown in **Figure 6**.

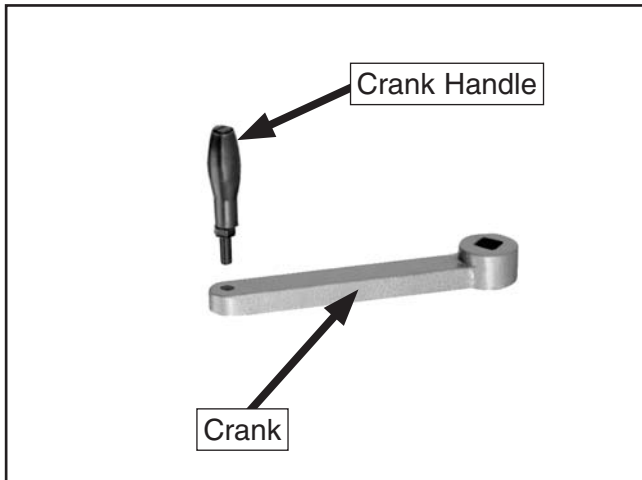

**Figure 6.** Crank assembly.

2. Slide the crank onto the crank shaft until the crank stops against the beveled shoulders of the shaft. Insert and tighten the M8-1.25 x 40 hex bolt to secure the crank in place (**Figure 7**).

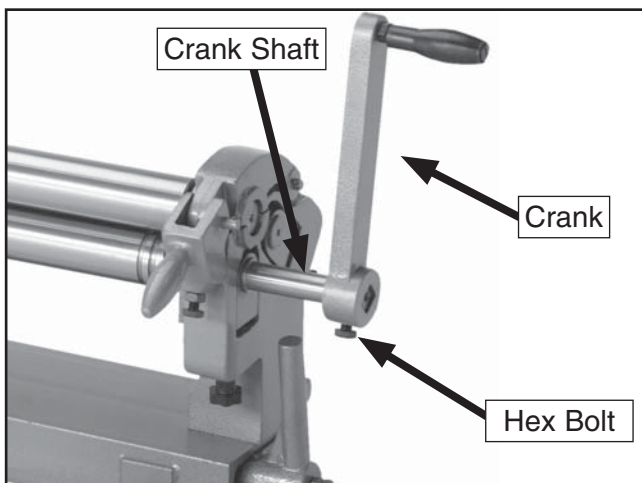
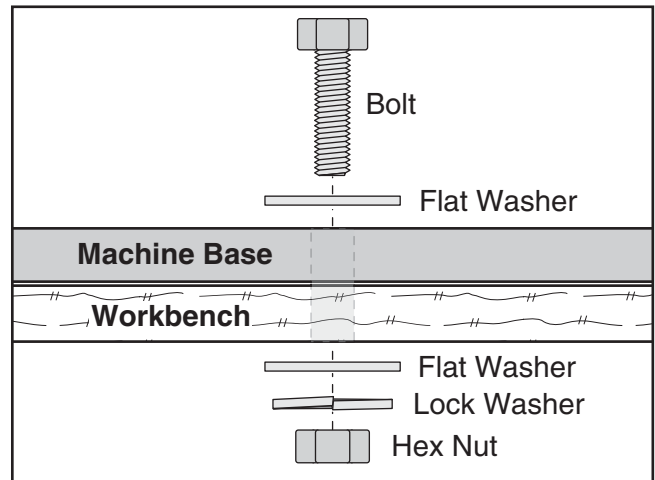

**Figure 7.** Crank mounting.

# Mounting

Once you have confirmed that your machine is assembled and functioning properly, mount it to a workbench through the holes in the base.

The strongest mounting option is a "Through Mount" where holes are drilled all the way through the workbench, and hex bolts, washers, and hex nuts are used to secure the machine to the workbench.



**Figure 8.** Example of a through mount setup.

Another option for mounting is a "Direct Mount" where the machine is simply secured to the workbench with lag screws.

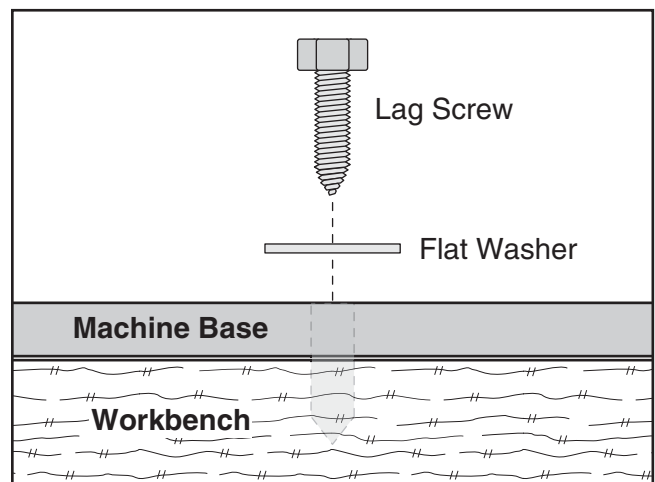

**Figure 9.** Example of a direct mount setup.



# SECTION 3: OPERATIONS

## **⚠️ WARNING**

Damage to your eyes, hands and feet could result from using this machine without proper protective gear. Always wear safety glasses, leather gloves, and steel toe footwear when operating this machine.

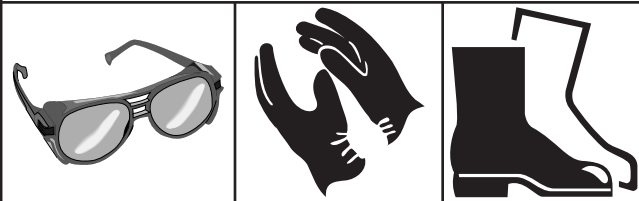

## **NOTICE**

If you have never used this type of machine or equipment before, WE STRONGLY RECOMMEND that you read books, trade magazines, or get formal training before beginning any projects. Regardless of the content in this section, Grizzly Industrial will not be held liable for accidents caused by lack of training.

## Basic Controls

Use the descriptions and figures below to become familiar with the basic controls of your slip roll.

**Thickness Adjust Knob:** Raises and lowers the bottom roller to adjust for different thicknesses.

**Radius Adjust Knob:** Raises and lowers the rear roller to create smaller and larger radius bends.

**Top Roller Lift Lever:** Lifts the top roller to allow removal of cylindrical workpieces.

**Crank:** Turns the rollers, feeding the workpiece through the machine.

**Top Roller Release Lever:** Lifts to release the upper bushing assembly.

**Upper Bushing Assembly:** Opens to allow movement of the top roller.

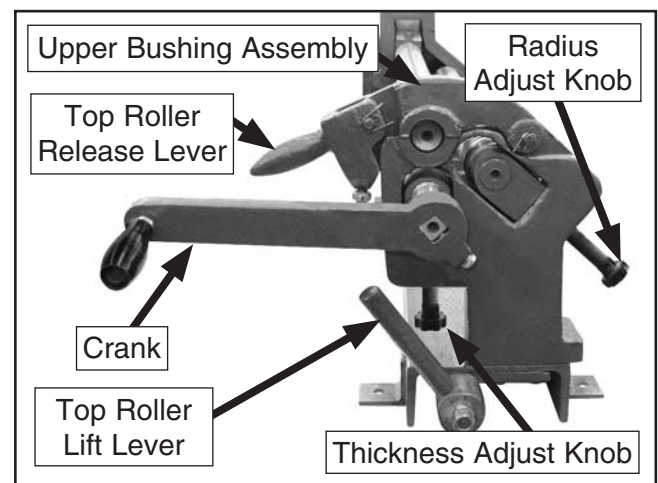

Figure 10. Adjustment knobs.



# Preparation

Before every use, follow these procedures to set up your slip roll for safe, accurate, and efficient use.

## To prepare the slip roll for use:

1. Turn the thickness adjust knob to lower the bottom roller to approximately  $\frac{1}{4}$ " below the top roller. Use calipers or a spacer to set the distance between the rollers evenly at each end (**Figure 11**).

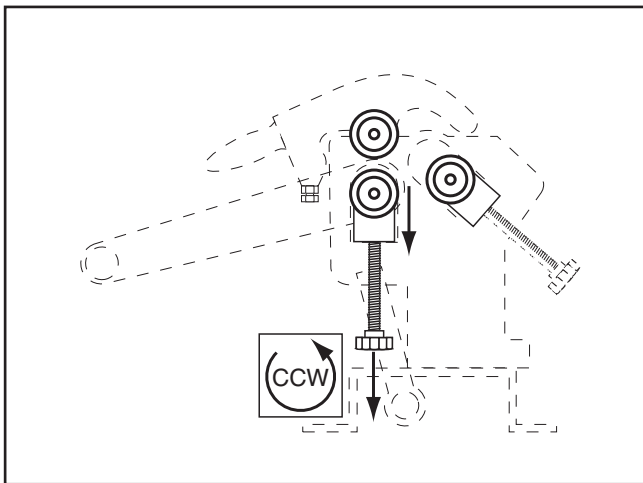

**Figure 11.** Bottom roller preparation.

2. Lower the rear roller as far as possible. Use calipers or a spacer to set the distance between the rear roller and top roller evenly at each end (**Figure 12**).

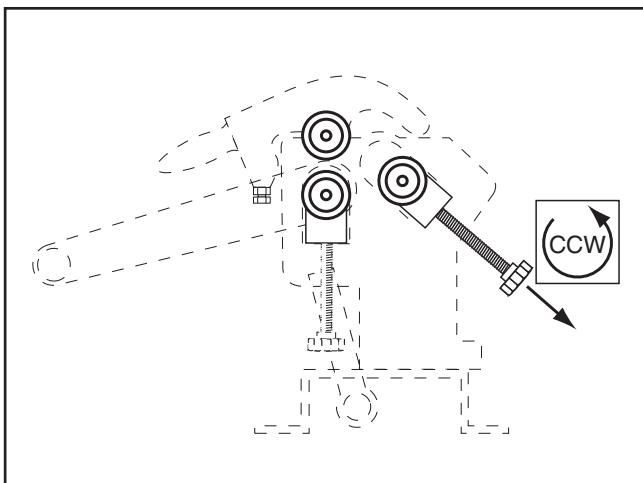

**Figure 12.** Rear roller preparation.

# Flat Rolling

The Model T21318 can be used to flat roll sheet metal up to 22 gauge. This can be done to straighten, flatten, and slightly reduce the thickness of soft workpieces such as brass, copper, and aluminum.

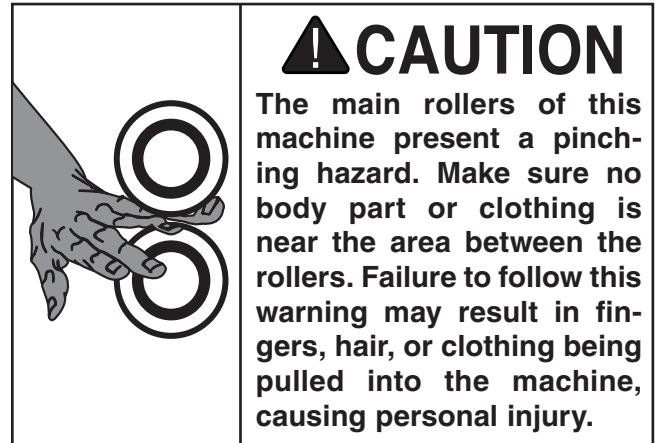

## To flat roll a workpiece:

1. Place the workpiece between the top and bottom rollers, as shown in **Figure 13**. Turn the thickness adjust knobs to lift the bottom roller until the workpiece is held snug between the top and bottom rollers. Be sure to turn the thickness adjust knobs on both ends of the roller equal amounts.

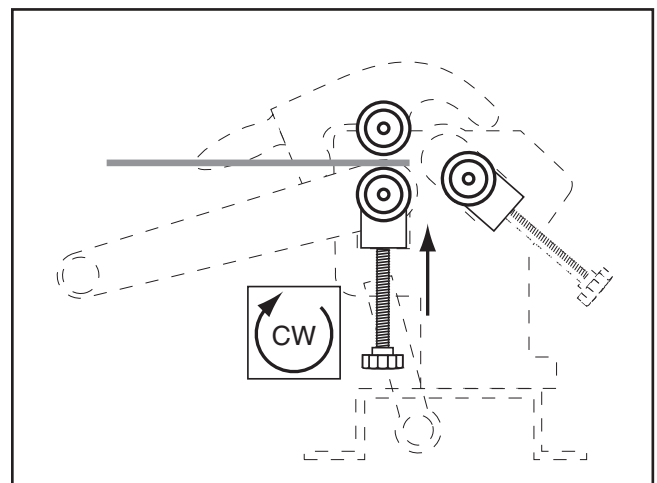

**Figure 13.** Raising bottom roller for flat rolling.



- Remove the workpiece from between the rollers, then raise the bottom roller slightly by rotating each thickness adjust knob approximately  $\frac{1}{4}$  turn. Also, make sure the rear roller is lowered completely and will not interfere with the workpiece as it exits the machine (**Figure 14**).

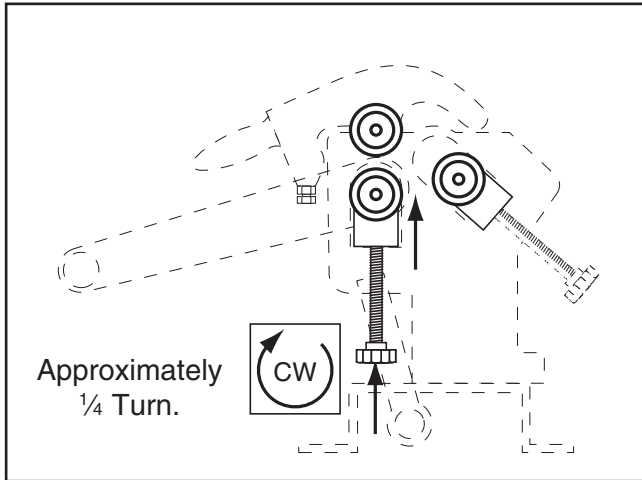

**Figure 14.** Raising bottom roller  $\frac{1}{4}$  turn.

- With the help of an assistant, feed the workpiece into the rollers while turning the crank (**Figure 15**).

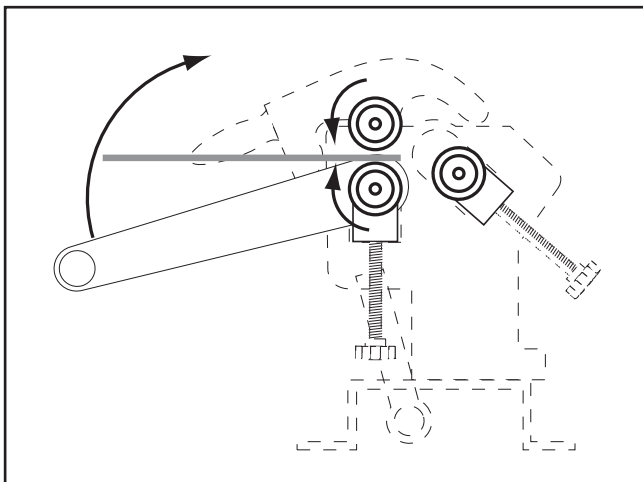

**Figure 15.** Flat rolling the workpiece.

- Continue processing the workpiece by repeating **Steps 2** and **3**, flipping the workpiece each time until the desired results are produced.

**Note:** Since the rear roller on the Model T21318 does not lower completely out of the path of the workpiece, a slight bend may be created. Flipping the workpiece between passes minimizes the bending effect.

## Creating Bends

The Model T21318 can easily create constant-radius bends in sheet metal up to 22 gauge.

**Note:** The method for creating a specific radius is a trial-and-error process. Due to the many variations among metal workpieces, no single positioning will create the same curve on all materials. We recommend using scrap pieces the same dimensions and material as your final workpiece until the desired curve is achieved.

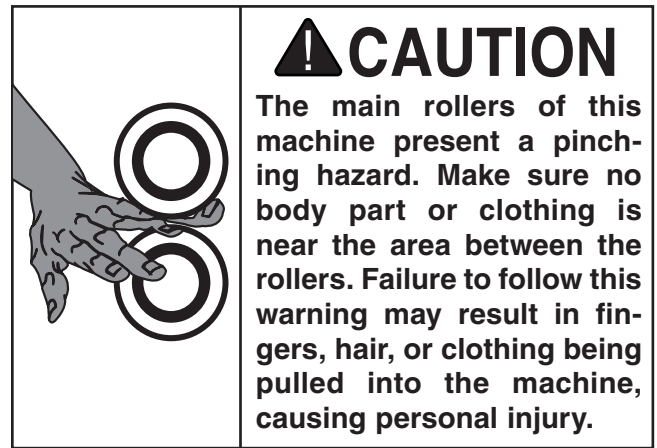

**To create a bend in a workpiece:**

- Place the workpiece between the top and bottom rollers, as shown in **Figure 16**. Turn the thickness adjust knobs to raise the bottom roller until the workpiece is held snug between the top and bottom rollers. Be sure to turn the thickness adjust knobs equal amounts.

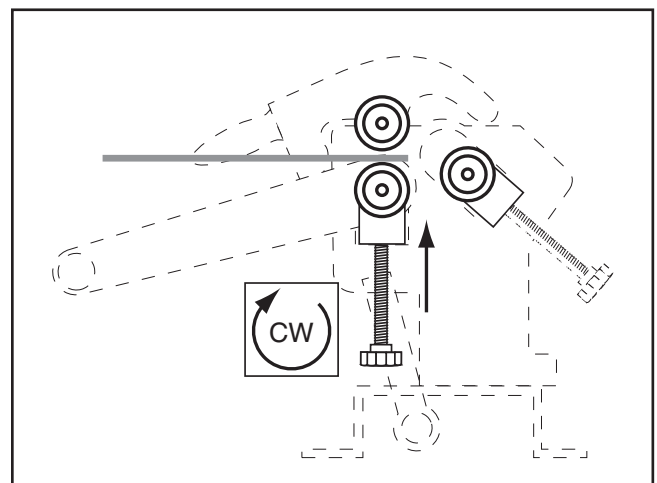

**Figure 16.** Raising bottom roller.



- Turn the crank clockwise to feed the workpiece until its front edge is directly above the rear roller, as shown in **Figure 17**.

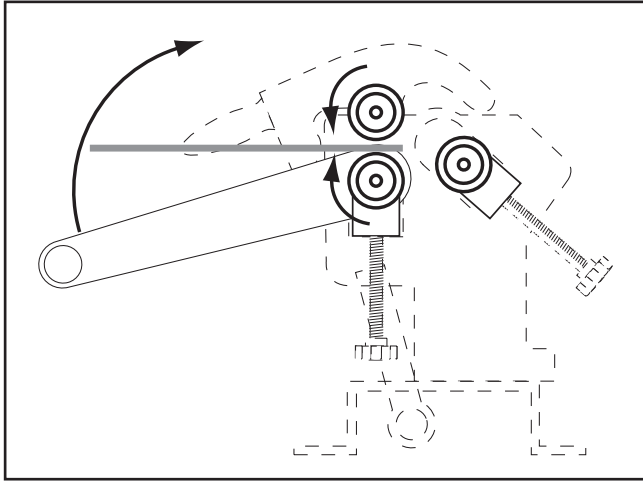

**Figure 17.** Feeding the workpiece.

- Turn the radius adjust knobs to lift the rear roller until the desired radius bend is reached (**Figure 18**). Make sure to turn the knobs equal amounts so the rear roller is always parallel with the other rollers. Failure to do so will create a larger radius on one end than the other, resulting in a cone or spiral shape.

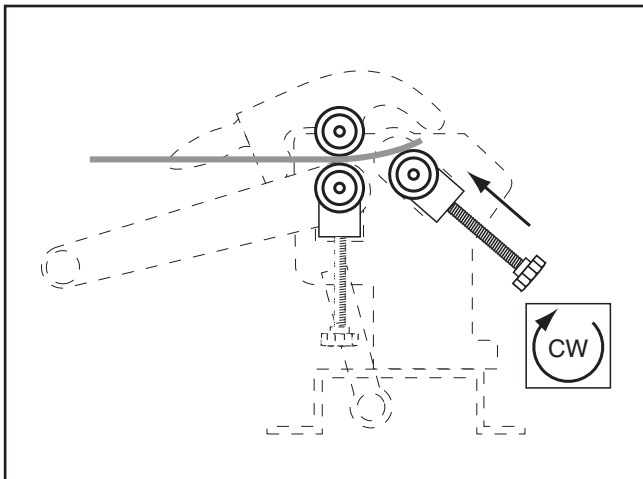

**Figure 18.** Setting the radius.

## ! WARNING

This machine poses a crushing hazard if workpieces are not properly supported when exiting the rollers. If necessary, get assistance to support the workpiece. Make sure all helpers are wearing safety glasses, leather gloves, and steel toed footwear when assisting in the use of this machine.

		
--	---	---

- Turn the crank to process the material through the slip roll. Continue turning until the workpiece is completely through the top and bottom rollers (**Figure 19**).

## ! CAUTION

Depending on the size and shape of your workpiece, you may need assistance to support the workpiece as it exits the machine. Failure to adequately support the workpiece may result in the workpiece falling, causing injuries.

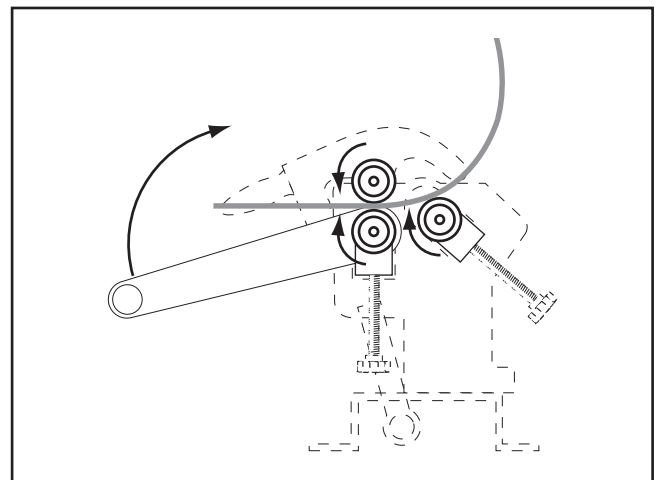

**Figure 19.** Processing the workpiece.



# Creating Cylinders

The Model T21318 Slip Roll can be used to easily and accurately create cylinders.

If you know the diameter of the cylinder you want to create, use the formula below to calculate the length of material needed.

$$C = \pi D$$

C=Circumference  
(Length of Material Needed)

$\pi$ =Pi (Approximately 3.142)

D=Diameter

**Example:** Suppose you want to create a 6" diameter cylinder. You would use the above formula as follows:

$$C = \pi D$$
$$C = (3.142) \times 6"$$
$$C = 18.852"$$

The result of 18.852" indicates that you need to start with a piece of sheet metal that is approximately 18.852" in length in order to create a 6" diameter cylinder.

You can use the slip roll to create a bend with the correct radius so that the two ends meet, forming a 6" diameter cylinder (**Figure 20**).

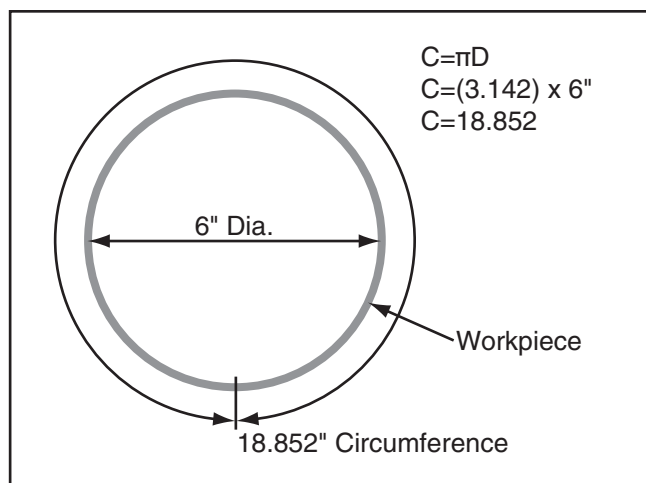

**Figure 20.** Calculating circumference example.

Once you have the necessary length workpiece, follow the steps below to create the cylinder.

**Note:** The method for creating a specific radius is a trial-and-error process. Due to the many variations among metal workpieces, no single positioning will create the same curve on all materials. We recommend using scrap pieces the same dimensions and material as your final workpiece until the desired curve is achieved.

**To create a cylinder:**

1. Place the workpiece between the top and bottom rollers, as shown in **Figure 21**. Turn the thickness adjust knobs to lift the bottom roller until the workpiece is held snug between the top and bottom rollers. Be sure to turn the thickness adjust knobs equal amounts.

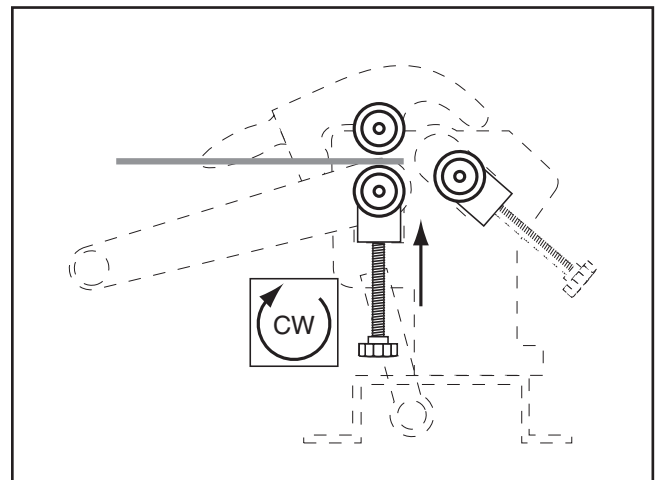
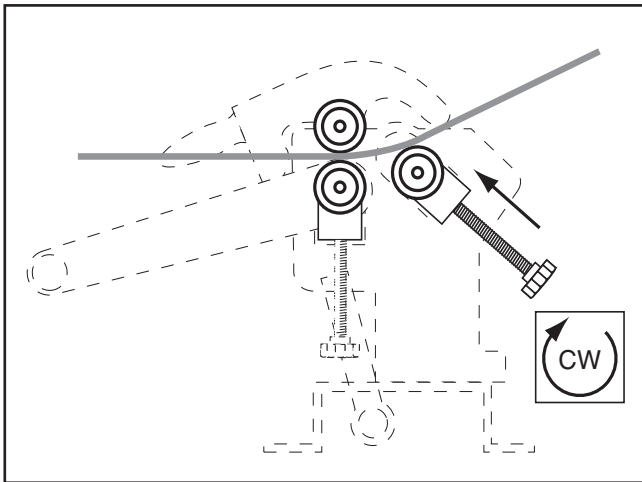

**Figure 21.** Raising bottom roller.



2. Turn the crank clockwise to feed the workpiece until it is approximately halfway through the rollers.
3. Turn the radius adjust knobs to lift the rear roller until the desired radius bend is reached (**Figure 22**). Make sure to turn the knobs equal amounts so the rear roller is always parallel with the other rollers. Failure to do so will create a larger radius on one end than the other, resulting in a cone shape.

**Note:** Always err on the side of making the radius too large rather than too small. It is easy to decrease the radius but very difficult to increase the radius later.



**Figure 22.** Setting the radius.

4. Turn the crank to process the material through the slip roll. Continue turning until the workpiece is completely through the top and bottom rollers (**Figure 23**).

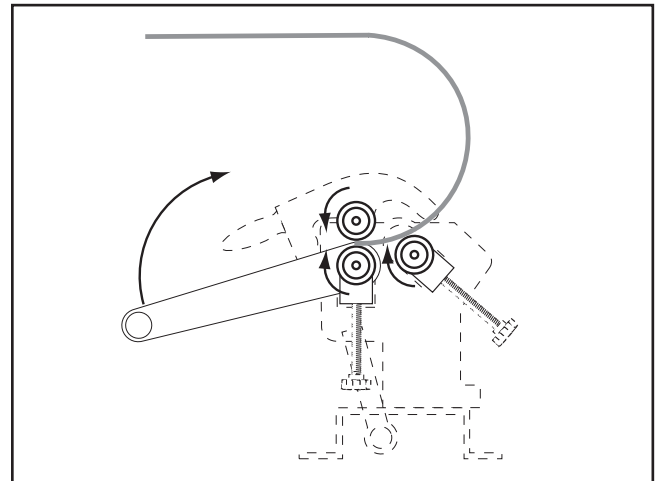

**Figure 23.** Processing the workpiece.

5. Rotate the workpiece 180°, insert the curved end into the slip roll, then process the workpiece through the machine, as shown in **Figures 24** and **25**.

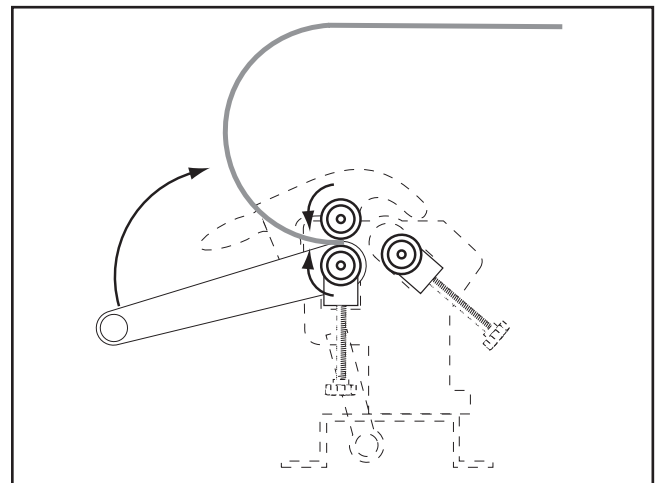

**Figure 24.** Re-inserting the workpiece.

**⚠ CAUTION**

Depending on the size and shape of your workpiece, you may need assistance to support the workpiece as it exits the machine. Failure to adequately support the workpiece may result in the workpiece falling, causing crushing injuries.

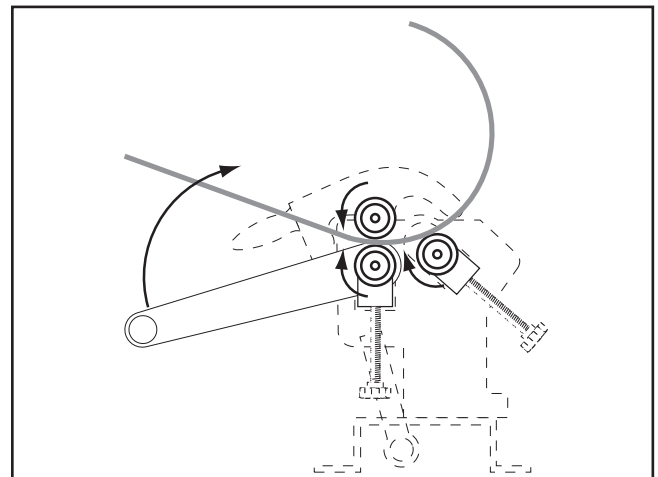

**Figure 25.** Creating the cylinder.



6. Continue to process the workpiece until the cylinder is formed, as shown in **Figure 26**.

—If the ends of the cylinder do not meet, lift the rear roller equally at both ends, then process the entire cylinder through the slip roll again. Repeat as necessary.

—If the ends of the cylinder overlap, remove the cylinder as described in **Removing Workpiece on Page 20**. Then, either attempt to increase the radius by manually bending it, or scrap the workpiece. Lower the rear roller equally at both ends then process a new workpiece through the slip roll. Repeat this step as necessary.

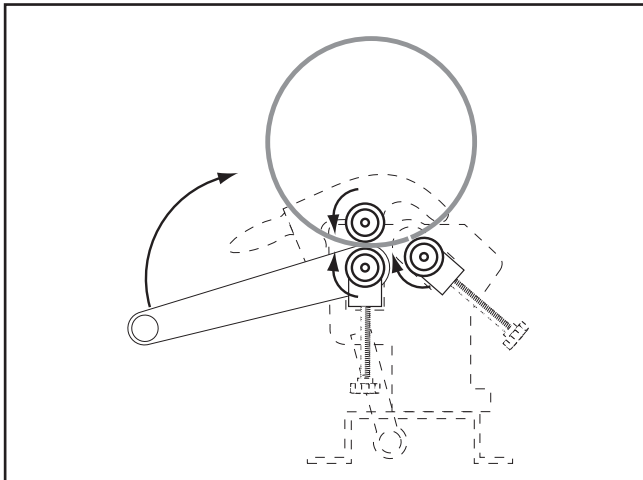

**Figure 26.** Finishing the cylinder.

7. Remove the workpiece as described in **Removing Workpiece on Page 20**.

## Bending Wire

The Model T21318 Slip Roll can be used to shape wires, rods, and small-diameter tubing. Also, the wire grooves can be used when rolling sheet metal that has a wire bead at one end.

### To use the wire grooves:

1. Place your workpiece into the smallest possible groove on the wheel. The three sizes are  $\frac{3}{16}$ ",  $\frac{1}{4}$ ", and  $\frac{5}{16}$ " (**Figure 27**).

**Example:** Suppose you want to bend a piece of  $\frac{1}{8}$ " rod. Though it would fit in any of the three grooves, you would use the  $\frac{3}{16}$ " groove since it is the smallest possible groove that the rod will fit into.

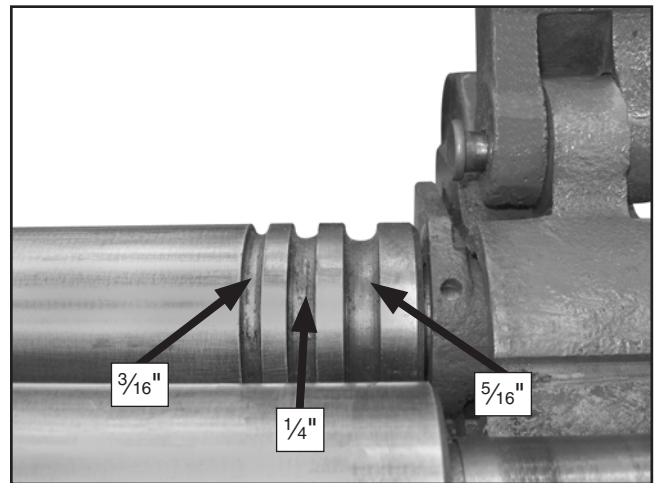

**Figure 27.** Wire grooves.

2. Process the material through the machine as described in **Creating Bends on Page 15**.

—If you want to make a loop of wire, follow the instructions in **Creating Cylinders on Page 17**.



# Removing Workpiece

## To remove cylindrical workpieces:

1. Loosen the jam nut and hex bolt until the top roller release lever can be lifted (**Figure 28**).

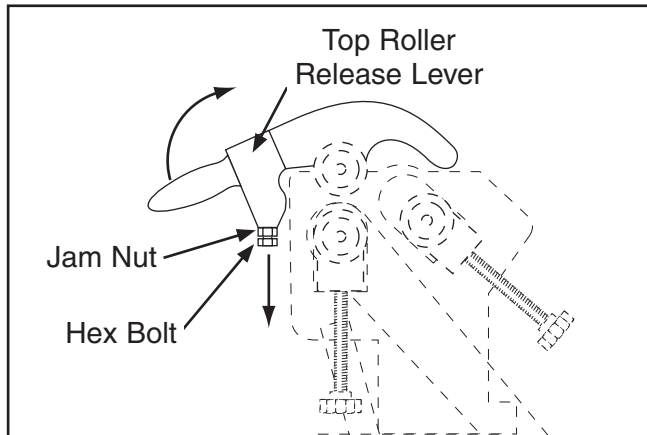

**Figure 28.** Hex bolt and jam nut.

2. Lift the top roller release lever, then open the upper bushing assembly (**Figure 29**).

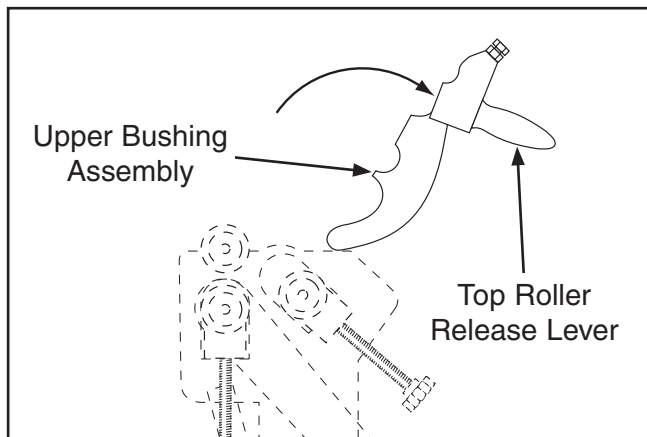
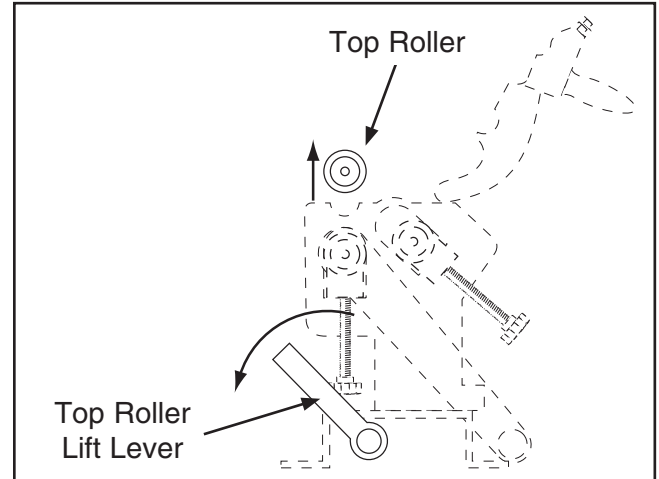

**Figure 29.** Upper bushing assembly release.

## **CAUTION**

The components of this machine are very heavy and workpieces can be cumbersome and have sharp edges. Always wear gloves and fully support components and workpieces. Get help if necessary. Failure to do this may result in personal injury.

3. Move the top roller lift lever, as shown in **Figure 30**, to raise the top roller. Remove the workpiece.



**Figure 30.** Releasing top roller.

4. Return the top roller lift lever to its original position, close the upper bushing assembly, then lower the top roller release lever (**Figure 31**).

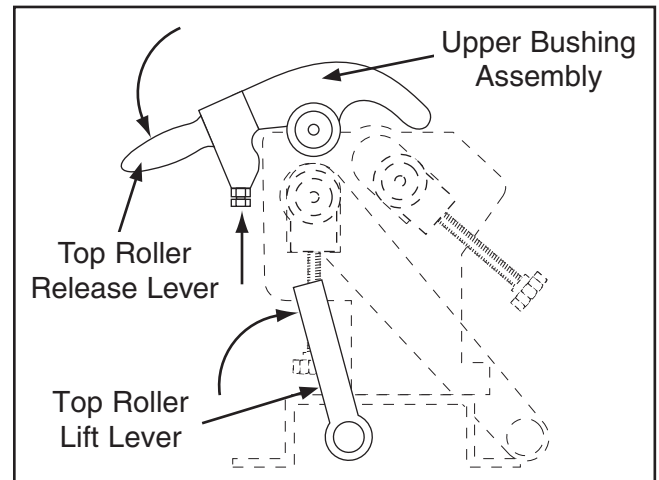

**Figure 31.** Securing top roller.

5. Finger-tighten the hex bolt and jam nut to secure the top roller bushing.



# SECTION 4: ACCESSORIES

## G5618—Deburring Tool with two Blades

The quickest tool for smoothing freshly sheared metal edges. Comes with two blades, one for steel and aluminum and one for brass and cast iron.



Figure 32. Model G5618 Deburring tool.

## G2871—Boeshield® T-9 12 oz Spray

## G2870—Boeshield® T-9 4 oz Spray

This ozone friendly protective spray penetrates deep and really holds up against corrosive environments. Lubricates metals for months and is safe for use on most paints, plastics, and vinyls.



Figure 33. Boeshield® T-9 spray.

## H6073—Deluxe Power Snip

Lightweight aluminum cast handles. Full 3½" length of cut. Replaceable steel blades. Fully enclosed finger loops protect hands from sharp edges. Long handles provide plenty of leverage. Multi-purpose snip for sheet metal, vinyl and plastic.



Figure 34. Model H6073 Deluxe Power Snip.

## G5562—SLIPIT® 1 Qt. Gel

## G5563—SLIPIT® 12 oz Spray

Used on cast iron table surfaces and other unpainted metal surfaces to reduce sliding friction and hangups. This product also reduces rust and prevents resin build-up.



Figure 35. SLIPIT® gel and spray.

Call 1-800-523-4777 To Order



### **G4956—Super Nibbler**

The super nibbler is just the ticket for cutting sheet metal up to  $\frac{3}{64}$ " thick. Extremely narrow headed design allows cuts in hard-to-reach areas, yet still features a safety guard to prevent flying splinters. 10 $\frac{1}{4}$ " overall.



**Figure 36.** Model G4956 Super Nibbler.

### **H5958—Sheet Metal Pliers**

For bending and forming sheet metal. Jaws are 3 $\frac{1}{2}$ " side. Rubber grips. Overall length is 8". Ideal for HVAC Installers.



**Figure 37.** Model H5958 Sheet Metal Pliers.

### **G8781—4 $\frac{1}{2}$ " Suction Cup**

Handle plate glass, glass mirrors and sheet metal with safety and security. Simple hand lever action provides tremendous gripping power on any flat, smooth material. Buy two Suction Cups for two-handed control!



**Figure 38.** Model G8781 4- $\frac{1}{2}$ " Suction Cup.

### **H6131—Heavy-Duty Hand Riveter**

Whether you're a full time sheet metal fabricator, or just making occasional repairs, you might as well invest in the best. This Heavy-Duty Hand Riveter with reinforced cast construction will be one of your most dependable tools.



**Figure 39.** Model H6131 Heavy-Duty Hand Riveter.

**Call 1-800-523-4777 To Order**



# SECTION 5: MAINTENANCE

## Schedule

For optimum performance from your machine, follow this maintenance schedule and refer to any specific instructions given in this section.

### Daily Check:

- Loose mounting bolts.
- Any other unsafe condition.

### Weekly Maintenance:

- Clean machine.
- Lubricate gears.
- Lubricate bushings.

## Cleaning

Cleaning the Model T21318 is relatively easy. Periodically wipe down the machine to remove dust and oil. Treat all unpainted cast iron and steel with a non-staining lubricant after cleaning.

## Unpainted Cast Iron

Protect the unpainted cast iron surfaces on the machine by wiping it clean after every use—this ensures rust-promoting debris does not remain on bare metal surfaces.

Keep the machine rust-free with regular applications of products like SLIPIT®, or Boeshield® T-9 (see **Section 5: Accessories** on **Page 21** for more details).

## Lubrication

Lubricating the Model T21318 consists of applying lubricant to the gears, adjustment screws, and the roller bushings.

### Grease Locations (Figure 40)

Remove the gear cover and brush a light coat of multi-purpose grease on the gear teeth. Turn the crank to disperse the grease. Also apply grease to the roller adjustment screws (not shown).

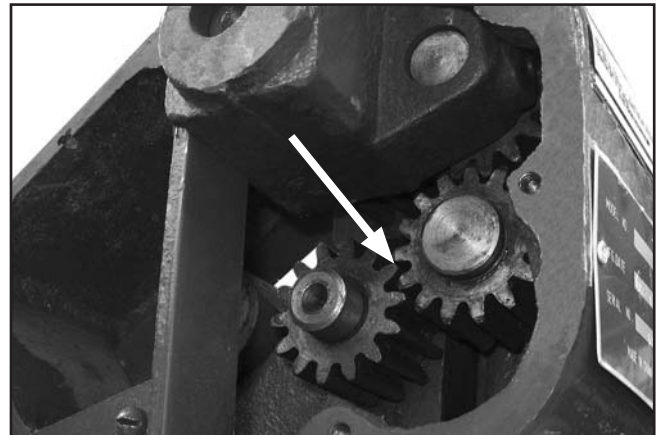

Figure 40. Grease location.

### Oiling Bushings (Figure 41)

Apply several drops of SAE 30 or equivalent oil from an oil can into the oil holes at both ends of each roller and to the exposed bushing surfaces. Turn the crank several times to disperse the oil. Wipe off excess oil.

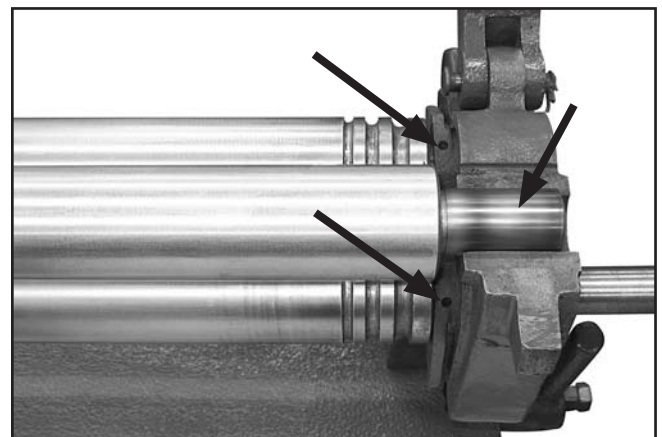

Figure 41. Oil locations.



# SECTION 6: SERVICE

---

---

Review the troubleshooting and procedures in this section to fix or adjust your machine if a problem develops. If you need replacement parts or you are unsure of your repair skills, then feel free to call our Technical Support at (570) 546-9663.

## Troubleshooting

---

---

### Operations

Symptom	Possible Cause	Possible Solution
Slip roll creates cones when trying to create cylinders.	1. Rollers are not parallel.	1. Adjust rear roller adjustment knobs as necessary to be sure the rear roller and top roller are parallel.
A noticeable crease is formed in the workpiece.	1. Excessive pressure applied in one spot.	1. Reduce the radius and perform the bend in several passes.
Crank does not turn top and bottom rollers.	1. Gears are damaged.	1. Check/Replace gears.
Slip roll does not bend material.	1. Machine capacities exceeded. 2. Rear roller not engaged.	1. Use materials within the capacity of the slip roll. 2. Check/Adjust rear roller.



# Parts Breakdown & List

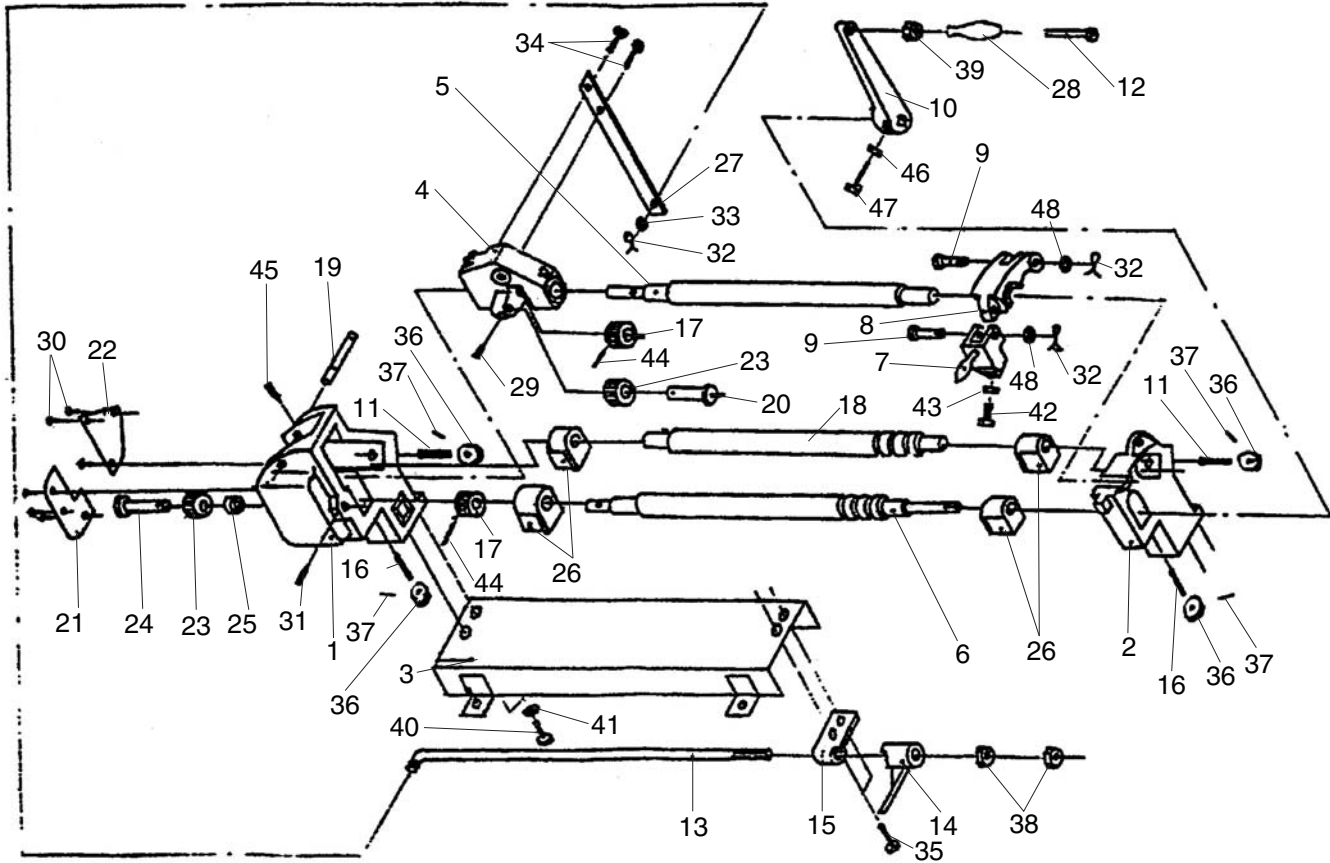

REF	PART #	DESCRIPTION
1	PT21318001	LEFT FRAME
2	PT21318002	RIGHT FRAME
3	PT21318003	BASE
4	PT21318004	ROLLER BASE
5	PT21318005	TOP ROLLER
6	PT21318006	BOTTOM ROLLER
7	PT21318007	LOCK KNOB
8	PT21318008	COVER
9	PT21318009	CLEVIS PIN 10 X 50
10	PT21318010	CRANK HANDLE
11	PT21318011	RADIUS ADJUST SCREW
12	PT21318012	SPECIAL SCREW
13	PT21318013	DRAW BAR
14	PT21318014	KNOB
15	PT21318015	DRAW BAR STAND
16	PT21318016	THICKNESS ADJUST SCREW
17	PT21318017	GEAR
18	PT21318018	REAR ROLLER
19	PT21318019	PIVOT SHAFT
20	PT21318020	IDLER GEAR SHAFT
21	PT21318021	COVER FRONT
22	PT21318022	COVER REAR
23	PT21318023	IDLER GEAR
24	PT21318024	GEAR LOCKING SHAFT

REF	PART #	DESCRIPTION
25	PT21318025	BUSHING 20 X 34 X 16
26	PT21318026	ROLLER STAND
27	PT21318027	LEVER
28	PT21318028	HANDLE
29	PSB52M	CAP SCREW M8-1.25 X 10
30	PSB04M	CAP SCREW M6-1 X 10
31	PSB52M	CAP SCREW M8-1.25 X 10
32	PT21318032	COTTER PIN 3 X 18
33	PW06M	FLAT WASHER 12MM
34	PT21318034	HEX BOLT M10-1.5 X 15
35	PB35M	HEX BOLT M12-1.75 X 40
36	PT21318036	HANDLE KNOB 8 X 32
37	PRP42M	ROLL PIN 3 X 20
38	PN09M	HEX NUT M12-1.75
39	PN02M	HEX NUT M10-1.5
40	PB27M	HEX BOLT M12-1.75 X 30
41	PW06M	FLAT WASHER 12MM
42	PB116M	HEX BOLT M10-1.5 X 45
43	PN02M	HEX NUT M10-1.5
44	PRP91M	ROLL PIN 5 X 35
45	PSB52M	CAP SCREW M8-1.25 X 10
46	PN03M	HEX NUT M8-1.25
47	PB20M	HEX BOLT M8-1.25 X 35
48	PW04M	FLAT WASHER 10MM



# Labels Breakdown & Parts List

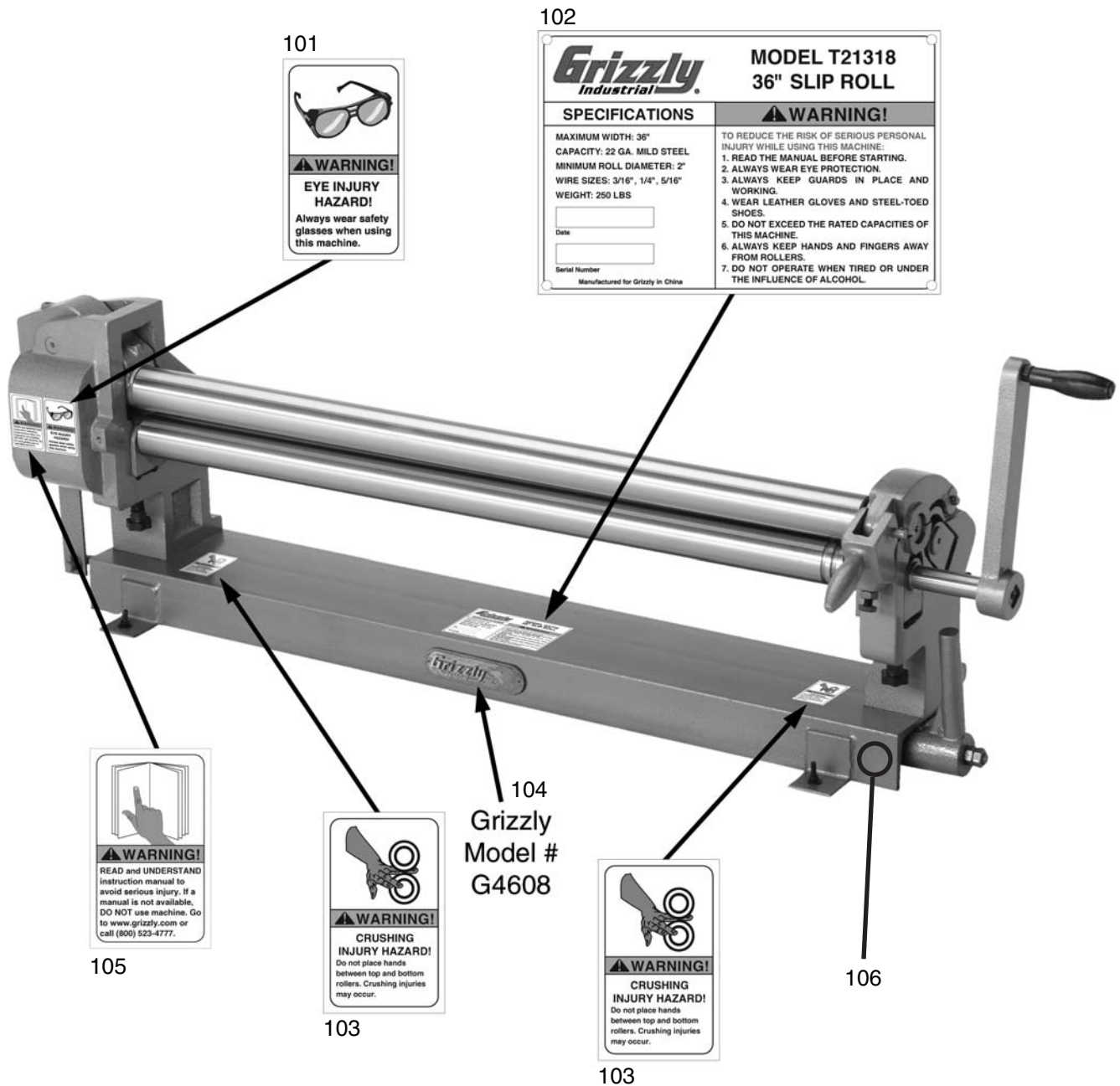

REF	PART #	DESCRIPTION
101	PLABEL-11B	SAFETY GLASSES WARNING
102	PT21318102	MACHINE ID LABEL
103	PT21318103	CRUSHING INJURY WARNING

REF	PART #	DESCRIPTION
104	G4608	GRIZZLY LOGO
105	PLABEL-12C	READ MANUAL LABEL
106	PPAINT-1	GREEN TOUCH-UP PAINT

## WARNING

Safety labels warn about machine hazards and ways to prevent injury. The owner of this machine **MUST** maintain the original location and readability of the labels on the machine. If any label is removed or becomes unreadable, **REPLACE** that label before using the machine again. Contact Grizzly at (800) 523-4777 or [www.grizzly.com](http://www.grizzly.com) to order new labels.





# WARRANTY CARD

Name \_\_\_\_\_  
 Street \_\_\_\_\_  
 City \_\_\_\_\_ State \_\_\_\_\_ Zip \_\_\_\_\_  
 Phone # \_\_\_\_\_ Email \_\_\_\_\_ Invoice # \_\_\_\_\_  
 Model # \_\_\_\_\_ Order # \_\_\_\_\_ Serial # \_\_\_\_\_

The following information is given on a voluntary basis. It will be used for marketing purposes to help us develop better products and services. **Of course, all information is strictly confidential.**

1. How did you learn about us?

Advertisement                       Friend                       Catalog  
 Card Deck                               Website                       Other:

2. Which of the following magazines do you subscribe to?

<input type="checkbox"/> Cabinet Maker	<input type="checkbox"/> Popular Mechanics	<input type="checkbox"/> Today's Homeowner
<input type="checkbox"/> Family Handyman	<input type="checkbox"/> Popular Science	<input type="checkbox"/> Wood
<input type="checkbox"/> Hand Loader	<input type="checkbox"/> Popular Woodworking	<input type="checkbox"/> Wooden Boat
<input type="checkbox"/> Handy	<input type="checkbox"/> Practical Homeowner	<input type="checkbox"/> Woodshop News
<input type="checkbox"/> Home Shop Machinist	<input type="checkbox"/> Precision Shooter	<input type="checkbox"/> Woodsmith
<input type="checkbox"/> Journal of Light Cont.	<input type="checkbox"/> Projects in Metal	<input type="checkbox"/> Woodwork
<input type="checkbox"/> Live Steam	<input type="checkbox"/> RC Modeler	<input type="checkbox"/> Woodworker West
<input type="checkbox"/> Model Airplane News	<input type="checkbox"/> Rifle	<input type="checkbox"/> Woodworker's Journal
<input type="checkbox"/> Modeltec	<input type="checkbox"/> Shop Notes	<input type="checkbox"/> Other:
<input type="checkbox"/> Old House Journal	<input type="checkbox"/> Shotgun News	

3. What is your annual household income?

\$20,000-\$29,000                       \$30,000-\$39,000                       \$40,000-\$49,000  
 \$50,000-\$59,000                       \$60,000-\$69,000                       \$70,000+

4. What is your age group?

20-29                                       30-39                                       40-49  
 50-59                                       60-69                                       70+

5. How long have you been a woodworker/metalworker?

0-2 Years                       2-8 Years                       8-20 Years                       20+ Years

6. How many of your machines or tools are Grizzly?

0-2                       3-5                       6-9                       10+

7. Do you think your machine represents a good value?       Yes                       No

8. Would you recommend Grizzly Industrial to a friend?       Yes                       No

9. Would you allow us to use your name as a reference for Grizzly customers in your area?  
**Note: We never use names more than 3 times.**       Yes                       No

10. Comments: \_\_\_\_\_  
 \_\_\_\_\_  
 \_\_\_\_\_  
 \_\_\_\_\_

CUT ALONG DOTTED LINE

FOLD ALONG DOTTED LINE

\_\_\_\_\_  
\_\_\_\_\_  
\_\_\_\_\_



Place  
Stamp  
Here



**GRIZZLY INDUSTRIAL, INC.**  
P.O. BOX 2069  
BELLINGHAM, WA 98227-2069



FOLD ALONG DOTTED LINE

Send a Grizzly Catalog to a friend:

Name \_\_\_\_\_  
Street \_\_\_\_\_  
City \_\_\_\_\_ State \_\_\_\_\_ Zip \_\_\_\_\_

TAPE ALONG EDGES--PLEASE DO NOT STAPLE

# WARRANTY AND RETURNS

---

Grizzly Industrial, Inc. warrants every product it sells for a period of **1 year** to the original purchaser from the date of purchase. This warranty does not apply to defects due directly or indirectly to misuse, abuse, negligence, accidents, repairs or alterations or lack of maintenance. This is Grizzly's sole written warranty and any and all warranties that may be implied by law, including any merchantability or fitness, for any particular purpose, are hereby limited to the duration of this written warranty. We do not warrant or represent that the merchandise complies with the provisions of any law or acts unless the manufacturer so warrants. In no event shall Grizzly's liability under this warranty exceed the purchase price paid for the product and any legal actions brought against Grizzly shall be tried in the State of Washington, County of Whatcom.

We shall in no event be liable for death, injuries to persons or property or for incidental, contingent, special, or consequential damages arising from the use of our products.

To take advantage of this warranty, contact us by mail or phone and give us all the details. We will then issue you a "Return Number," which must be clearly posted on the outside as well as the inside of the carton. We will not accept any item back without this number. Proof of purchase must accompany the merchandise.

The manufacturers reserve the right to change specifications at any time because they constantly strive to achieve better quality equipment. We make every effort to ensure that our products meet high quality and durability standards and we hope you never need to use this warranty.

Please feel free to write or call us if you have any questions about the machine or the manual.

Thank you again for your business and continued support. We hope to serve you again soon.

# *grizzly.com*<sup>®</sup>

**TOOL WEBSITE**

Buy Direct and Save with Grizzly<sup>®</sup> – Trusted, Proven and a Great Value!  
~Since 1983~

*Visit Our Website Today For Current  
Information On Events And Specials!*

- SECURE ORDERING
- ORDERS SHIPPED WITHIN 24 HOURS

-OR-

Call Today For A **FREE**  
Full Color Catalog

**1-800-523-4777**

