

### Introduction

This rolling tool cart with tool box requires some assembly. Follow the instructions under each **Figure** on the following page.

To begin, lay out all of the parts and compare quantities to the inventory list given below.

*If you need additional help with these instructions, call our service department at: (570) 546-9663.*

### Inventory (Figure 1)

<b>A.</b>	Tool Box w/ Upper Shelf .....	1
<b>B.</b>	Side Support.....	2
<b>C.</b>	Bottom Shelf.....	1
<b>D.</b>	Vertical Support.....	4
<b>E.</b>	Handle .....	1
<b>F.</b>	Plain Caster.....	2
<b>G.</b>	Pivoting Caster.....	2
<b>H.</b>	8mm Hex Bolt.....	2
<b>I.</b>	8mm Carriage Bolt .....	22
<b>J.</b>	8mm Hex Nut .....	24
<b>K.</b>	6mm Phlps. Head Screw.....	16
<b>L.</b>	6mm Hex Nut .....	16
<b>M.</b>	8mm Flat Washer.....	24
<b>N.</b>	Front/Back Support .....	2
<b>O.</b>	Angle Bracket.....	4

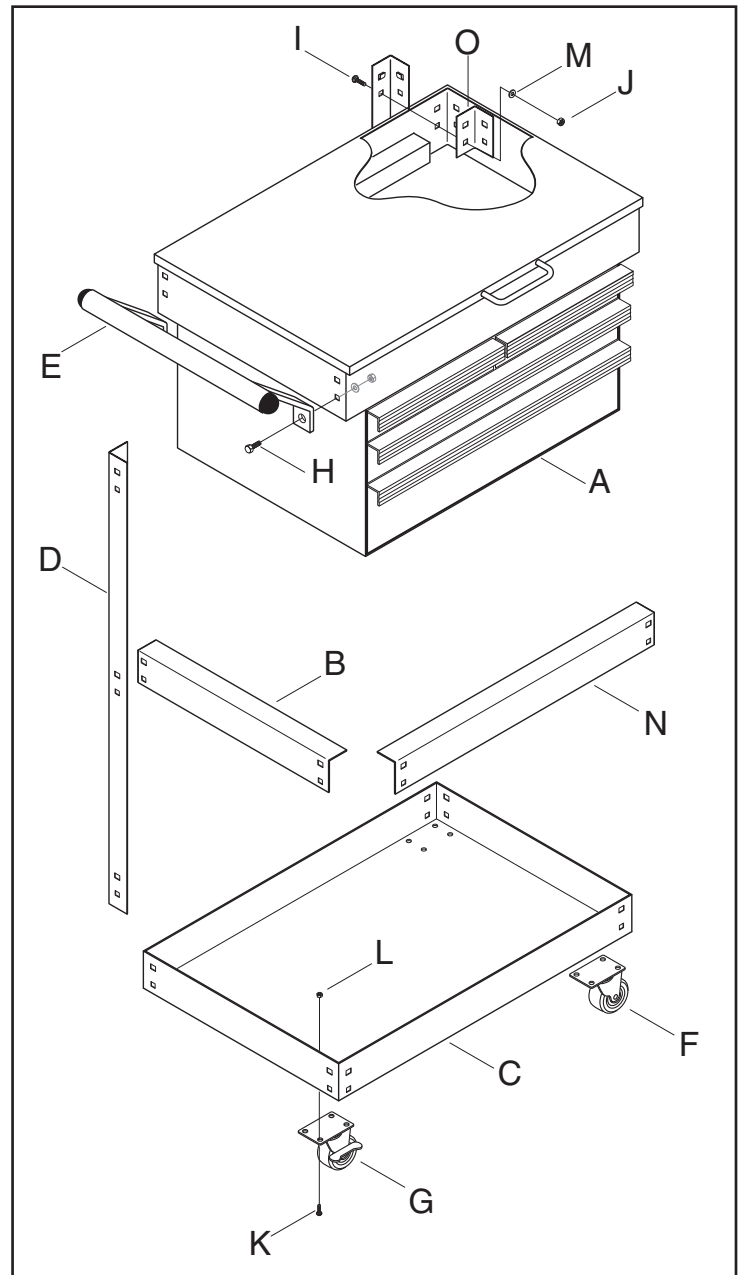

**Figure 1.** Inventory of parts.

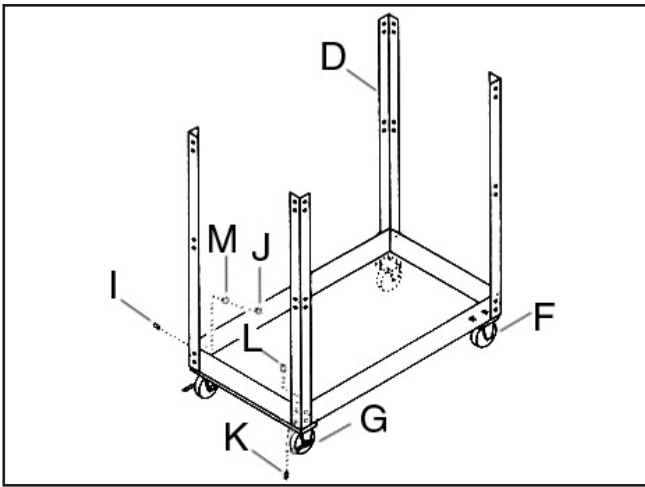

**Figure 2.** Assemble casters and vertical supports to bottom shelf.

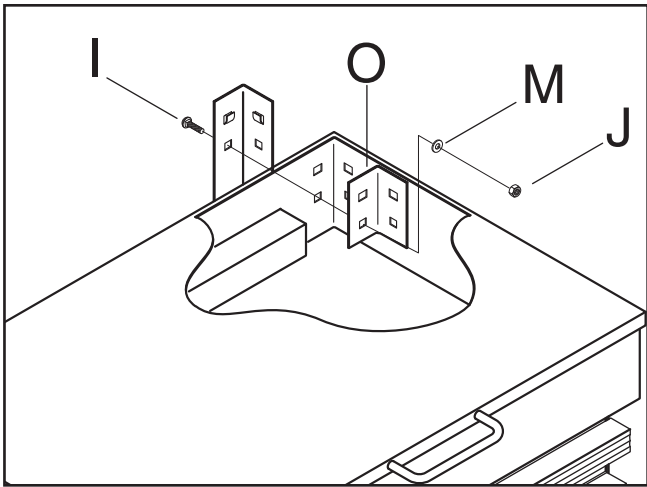

**Figure 5.** Details for assembly of the vertical support, the upper tray and the angle bracket.

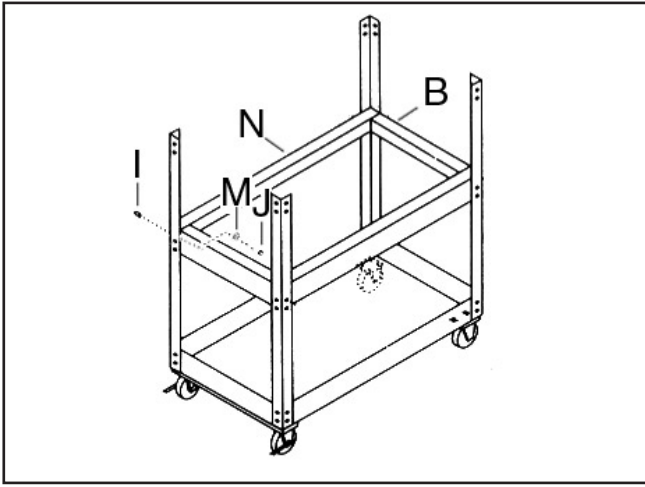

**Figure 3.** Assemble the side supports to the vertical supports.

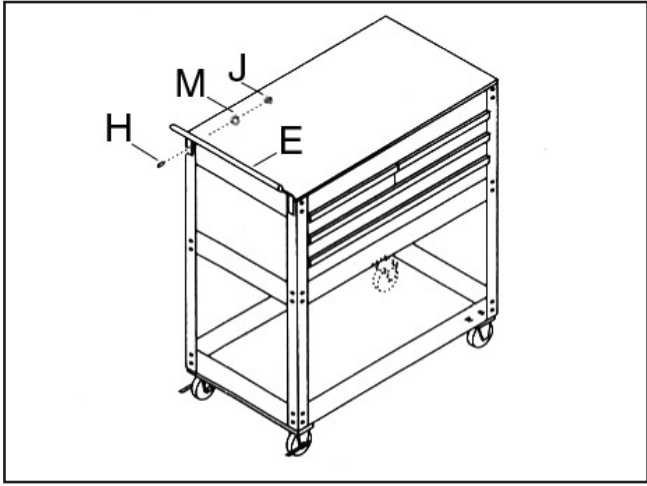

**Figure 6.** Assemble the handle onto the side of the tool box.

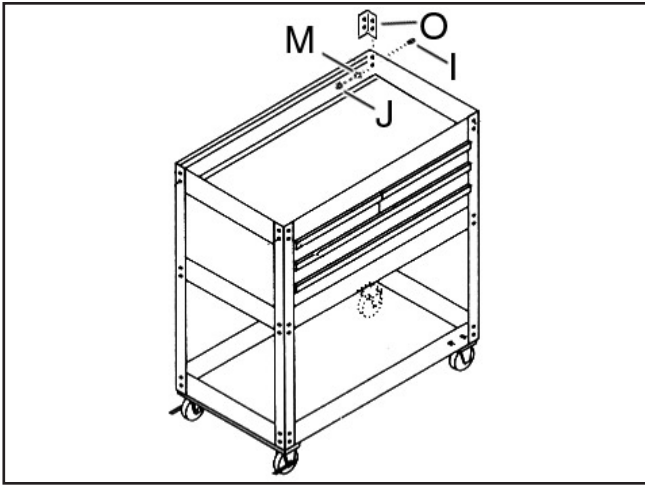

**Figure 4.** Set the tool box on top of the side supports and secure with screws, washers and nuts.