

# READ THIS FIRST



**Model G1140/G1531**  
**\*\*\*IMPORTANT UPDATE\*\*\***  
 For Machines Mfd. Since 08/14  
 and Owner's Manual Revised 04/18

For questions or help with this product contact Tech Support at (570) 546-9663 or [techsupport@grizzly.com](mailto:techsupport@grizzly.com)

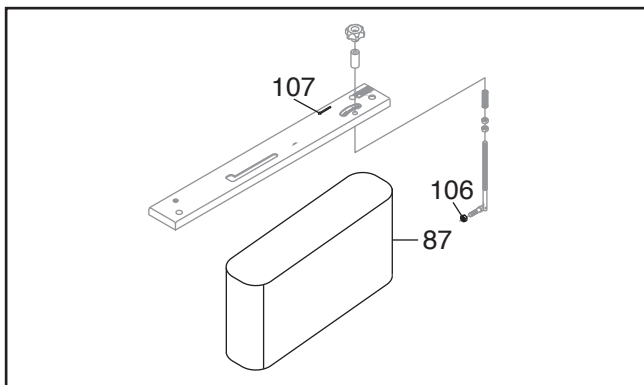
The following changes were recently made since the owner's manual was printed:

- Parts and specifications changed.

Aside from this information, all other content in the owner's manual applies and **MUST** be read and understood for your own safety. **IMPORTANT: Keep this update with the owner's manual for future reference.**

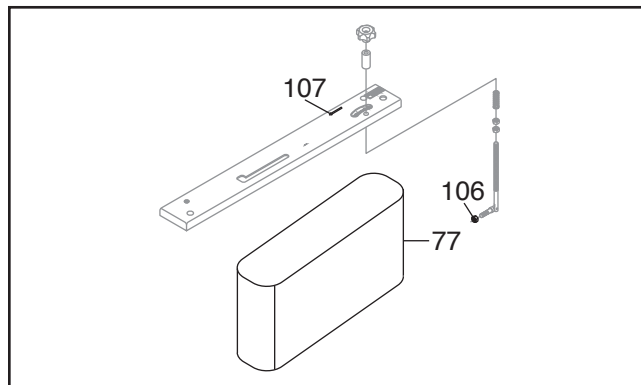
For questions or help, contact our Tech Support at (570) 546-9663 or [techsupport@grizzly.com](mailto:techsupport@grizzly.com).

## Revised Parts (G1140)



REF	PART #	DESCRIPTION
87	P1140087	BELT 6" X 80" P100
106	P1140106	HEX NUT 3/8-16
107	P1140107	BELT ROTATION LABEL

## Revised Parts (G1531)



REF	PART #	DESCRIPTION
77	P1531077	BELT 6" X 80" P100
106	P1531106	HEX NUT 3/8-16
107	P1531107	BELT ROTATION LABEL

## Revised Specifications (G1140)

### Product Dimensions:

Weight ..... 238 lbs.

### Shipping Dimensions:

Weight ..... 260 lbs.

### Motors:

#### Main

Horsepower ..... 1-1/2 HP

### Main Specifications:

#### Other Related Information

Mobile Base ..... T28922

## Revised Specifications (G1531)

### Motors:

#### Main

Horsepower ..... 1-1/2 HP

COPYRIGHT © JUNE, 2025 BY GRIZZLY INDUSTRIAL, INC.  
**WARNING: NO PORTION OF THIS MANUAL MAY BE REPRODUCED IN ANY SHAPE OR FORM WITHOUT THE WRITTEN APPROVAL OF GRIZZLY INDUSTRIAL, INC.**  
 #CM23662 PRINTED IN TAIWAN

# *Grizzly* *Industrial, Inc.*®

## MODEL G1140/G1531 6" X 80" EDGE SANDER

### OWNER'S MANUAL

*(For models manufactured since 8/14)*



COPYRIGHT © JULY, 2008 BY GRIZZLY INDUSTRIAL, INC., REVISED MAY, 2025 (CM)  
**WARNING: NO PORTION OF THIS MANUAL MAY BE REPRODUCED IN ANY SHAPE  
OR FORM WITHOUT THE WRITTEN APPROVAL OF GRIZZLY INDUSTRIAL, INC.**

#BL10851 PRINTED IN TAIWAN

V2.05.25

 **WARNING!**

**This manual provides critical safety instructions on the proper setup, operation, maintenance, and service of this machine/tool. Save this document, refer to it often, and use it to instruct other operators.**

**Failure to read, understand and follow the instructions in this manual may result in fire or serious personal injury—including amputation, electrocution, or death.**

**The owner of this machine/tool is solely responsible for its safe use. This responsibility includes but is not limited to proper installation in a safe environment, personnel training and usage authorization, proper inspection and maintenance, manual availability and comprehension, application of safety devices, cutting/sanding/grinding tool integrity, and the usage of personal protective equipment.**

**The manufacturer will not be held liable for injury or property damage from negligence, improper training, machine modifications or misuse.**

 **WARNING!**

**Some dust created by power sanding, sawing, grinding, drilling, and other construction activities contains chemicals known to the State of California to cause cancer, birth defects or other reproductive harm. Some examples of these chemicals are:**

- **Lead from lead-based paints.**
- **Crystalline silica from bricks, cement and other masonry products.**
- **Arsenic and chromium from chemically-treated lumber.**

**Your risk from these exposures varies, depending on how often you do this type of work. To reduce your exposure to these chemicals: Work in a well ventilated area, and work with approved safety equipment, such as those dust masks that are specially designed to filter out microscopic particles.**

# Table of Contents

<b>INTRODUCTION</b> .....	<b>2</b>	<b>SECTION 5: ACCESSORIES</b> .....	<b>29</b>
Foreword.....	2	<b>SECTION 6: MAINTENANCE</b> .....	<b>30</b>
Contact Info .....	2	Schedule.....	30
Functional Overview .....	2	Cleaning.....	30
Identification.....	3	Unpainted Cast Iron.....	30
G1140 Data Sheet .....	4	Lubrication .....	31
G1531 Data Sheet.....	6	<b>SECTION 7: SERVICE</b> .....	<b>32</b>
<b>SECTION 1: SAFETY</b> .....	<b>8</b>	Troubleshooting .....	32
Safety Instructions for Machinery .....	8	Adjusting Tensioner.....	34
Additional Safety for Edge Sanders.....	10	Resetting Tensioner Spring Tension .....	35
<b>SECTION 2: POWER SUPPLY</b> .....	<b>11</b>	Parallel Belt Tracking .....	36
<b>SECTION 3: SETUP</b> .....	<b>13</b>	Platen-Roller Adjustments .....	37
Setup Safety .....	13	G1140 Wiring Diagram .....	41
Items Needed for Setup.....	13	G1531 Wiring Diagram .....	42
Unpacking.....	13	<b>SECTION 8: PARTS</b> .....	<b>43</b>
Inventory .....	14	G1140 Parts Breakdown.....	43
Clean Up.....	15	G1531 Parts Breakdown.....	45
Site Considerations.....	15	<b>WARRANTY AND RETURNS</b> .....	<b>49</b>
Assembly .....	16		
Test Run & Tracking Belt .....	18		
Installing Work Table.....	20		
Installing End Table.....	22		
Back Stop (G1140) .....	23		
Dust Collection.....	23		
<b>SECTION 4: OPERATIONS</b> .....	<b>24</b>		
Operation Safety .....	24		
Basic Edge Sander Controls .....	24		
Horizontal Sanding (G1140) .....	27		
Sanding Tips .....	27		
Choosing Sandpaper .....	27		
Replacing Belt.....	28		
Tracking Belt.....	28		

# INTRODUCTION

## Contact Info

We stand behind our machines! If you have questions or need help, contact us with the information below. Before contacting, make sure you get the **serial number** and **manufacture date** from the machine ID label. This will help us help you faster.

Grizzly Technical Support  
1815 W. Battlefield  
Springfield, MO 65807  
Phone: (570) 546-9663  
Email: techsupport@grizzly.com

We want your feedback on this manual. What did you like about it? Where could it be improved? Please take a few minutes to give us feedback.

Grizzly Documentation Manager  
P.O. Box 2069  
Bellingham, WA 98227-2069  
Email: manuals@grizzly.com

### WARNING

Like all machinery there is potential danger when operating this machine. Accidents are frequently caused by lack of familiarity or failure to pay attention. Use this machine with respect and caution to lessen the possibility of operator injury. If normal safety precautions are overlooked or ignored, serious personal injury may occur.

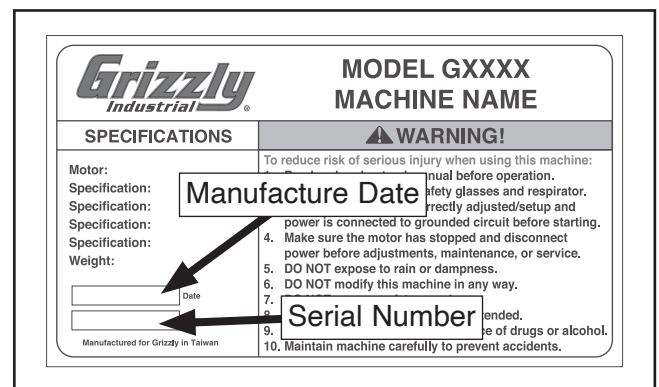
## Manual Accuracy

We are proud to provide a high-quality owner's manual with your new machine!

We made every effort to be exact with the instructions, specifications, drawings, and photographs in this manual. Sometimes we make mistakes, but our policy of continuous improvement also means that **sometimes the machine you receive is slightly different than shown in the manual.**

If you find this to be the case, and the difference between the manual and machine leaves you confused or unsure about something, check our website for an updated version. We post current manuals and manual updates for free on our website at [www.grizzly.com](http://www.grizzly.com).

Alternatively, you can call our Technical Support for help. Before calling, make sure you write down the **manufacture date** and **serial number** from the machine ID label (see below). This information is required for us to provide proper tech support, and it helps us determine if updated documentation is available for your machine.



# Identification

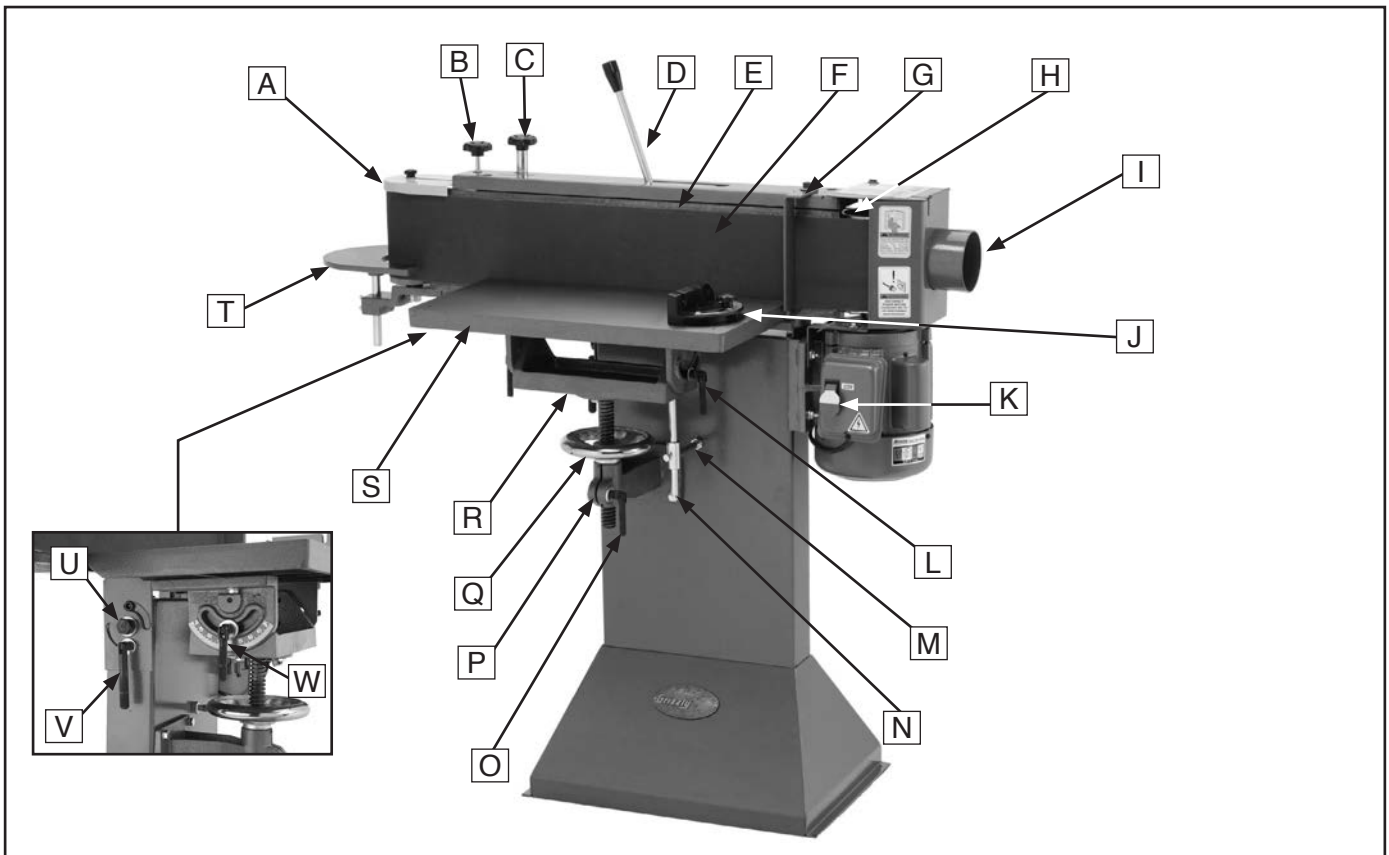
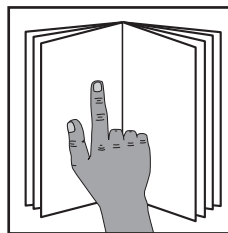


Figure 1. Model G1140/G1531 identification.

- |                           |   |
|---------------------------|---|
| A. Idler Roller Guard     | M. Horizontal Brace                     |
| B. Belt Tension Lock Knob | N. Vertical Brace                       |
| C. Belt Tracking Knob     | O. Leadscrew Bracket Lock Handle        |
| D. Tension Lever          | P. Leadscrew Bracket                    |
| E. Platen                 | Q. Table Height Handwheel               |
| F. Sanding Belt           | R. Table Bracket                        |
| G. Back Stop (G1140)      | S. Work Table                           |
| H. Main Roller            | T. End Table                            |
| I. Dust Port 4"           | U. Table Tilt Lock Bolt (Model G1140)   |
| J. Miter Gauge            | V. Table Tilt Lock Handle (Model G1140) |
| K. Paddle Switch          | W. Trunnion Lock Handle (Model G1140)   |
| L. Table Tilt Lock Handle |   |



## **⚠️ WARNING**

To reduce your risk of serious injury, read this entire manual **BEFORE** using machine.





# MACHINE DATA SHEET

Customer Service #: (570) 546-9663 · To Order Call: (800) 523-4777 · Fax #: (800) 438-5901

## MODEL G1140 6" X 80" FLOOR MODEL EDGE SANDER

### Product Dimensions:

Weight..... 238 lbs.  
 Width (side-to-side) x Depth (front-to-back) x Height..... 47 x 20 x 49 in.  
 Footprint (Length x Width)..... 21-1/2 x 15 in.

### Shipping Dimensions:

Type..... Cardboard Box  
 Content..... Machine  
 Weight..... 260 lbs.  
 Length x Width x Height..... 46 x 45 x 16 in.  
 Must Ship Upright..... Yes

### Electrical:

Power Requirement..... 110V or 220V, Single-Phase, 60 Hz  
 Prewired Voltage..... 220V  
 Full-Load Current Rating..... 20A at 110V, 10A at 220V  
 Minimum Circuit Size..... 30A at 110V, 15A at 220V  
 Connection Type..... Cord & Plug  
 Power Cord Included..... Yes  
 Power Cord Length..... 5-1/2 ft.  
 Power Cord Gauge..... 16 AWG  
 Plug Included..... No  
 Recommended Plug Type..... L5-30 at 110V, 6-15 at 220V  
 Switch Type..... Paddle Safety Switch w/Removable Key

### Motors:

#### Main

Horsepower..... 1-1/2 HP  
 Phase..... Single-Phase  
 Amps..... 20A/10A  
 Speed..... 1725 RPM  
 Type..... TEFC Capacitor-Start Induction  
 Power Transfer..... Direct Drive  
 Bearings..... Shielded & Permanently Lubricated  
 Centrifugal Switch/Contacts Type..... External

### Main Specifications:

#### Operation Information

Sanding Belt Speed..... 1800 FPM  
 Sanding Belt Length..... 80 in.  
 Sanding Belt Width..... 6 in.  
 Sanding Belt Tilt..... 0 – 90 deg.



**Table Information**

Table Length.....	22 in.
Table Width.....	10-1/2 in.
Table Thickness.....	1-1/4 in.
Table Tilt.....	-60 – 60 deg.
Table Travel.....	5 in.
Floor To Table Height.....	35 in.
End Table Length.....	8 in.
End Table Width.....	4-1/4 in.
End Table Thickness.....	1/2 in.
End Table Travel.....	3-1/2 in.

**Platen Information**

Platen Type.....	Graphite Coated
Platen Length.....	29-3/4 in.
Platen Width.....	6-3/4 in.

**Construction**

Table.....	Precision-Ground Cast Iron
Frame.....	Steel
Base.....	Steel
Drive Roller.....	Aluminum
Idler Roller.....	Rubber
Miter Block.....	Aluminum
Paint Type/Finish.....	Powder Coated

**Other Related Information**

Number of Dust Ports.....	1
Dust Port Size.....	4 in.
Belt Release.....	Quick Release
Drive Roller Size.....	4-1/4 in.
Idler Roller Size.....	3-3/8 in.
Mobile Base.....	T28922

**Other Specifications:**

Country of Origin .....	Taiwan
Warranty .....	1 Year
Approximate Assembly & Setup Time .....	30 Minutes
Serial Number Location .....	ID Label on Top of Sanding Belt Cover
ISO 9001 Factory .....	Yes
Certified by a Nationally Recognized Testing Laboratory (NRTL) .....	No

**Features:**

- Sanding Surface Tilts Vertical to Horizontal
- Includes Built-in Dust Hood and Miter Block
- Quick Belt Release
- Conveniently Located Belt Tracking and Tension Adjustment
- Handwheel Table Height Adjustment
- Powder Coated Finish
- Paddle Switch with Safety Key





# MACHINE DATA SHEET

Customer Service #: (570) 546-9663 · To Order Call: (800) 523-4777 · Fax #: (800) 438-5901

## MODEL G1531 6" X 80" BENCHTOP EDGE SANDER

### Product Dimensions:

Weight..... 200 lbs.  
 Width (side-to-side) x Depth (front-to-back) x Height..... 47 x 17-1/2 x 34-1/2 in.  
 Footprint (Length x Width)..... 22 x 11 in.

### Shipping Dimensions:

Type..... Cardboard Box  
 Content..... Machine  
 Weight..... 221 lbs.  
 Length x Width x Height..... 45 x 32 x 14 in.  
 Must Ship Upright..... Yes

### Electrical:

Power Requirement..... 110V or 220V, Single-Phase, 60 Hz  
 Prewired Voltage..... 220V  
 Full-Load Current Rating..... 20A at 110V, 10A at 220V  
 Minimum Circuit Size..... 30A at 110V, 15A at 220V  
 Connection Type..... Cord & Plug  
 Power Cord Included..... Yes  
 Power Cord Length..... 5-1/2 ft.  
 Power Cord Gauge..... 16 AWG  
 Plug Included..... No  
 Recommended Plug Type..... L5-30 at 110V, 6-15 at 220V  
 Switch Type..... Paddle Safety Switch w/Removable Key

### Motors:

#### Main

Horsepower..... 1-1/2 HP  
 Phase..... Single-Phase  
 Amps..... 20A/10A  
 Speed..... 1725 RPM  
 Type..... TEFC Capacitor-Start Induction  
 Power Transfer ..... Direct Drive  
 Bearings..... Shielded & Permanently Lubricated  
 Centrifugal Switch/Contacts Type..... External

### Main Specifications:

#### Operation Information

Sanding Belt Speed..... 1800 FPM  
 Sanding Belt Length..... 80 in.  
 Sanding Belt Width..... 6 in.



**Table Information**

Table Length.....	22 in.
Table Width.....	10-1/2 in.
Table Thickness.....	1-1/4 in.
Table Tilt.....	-60 – 60 deg.
Table Travel.....	5 in.
Floor To Table Height.....	19-1/2 in.
End Table Length.....	8 in.
End Table Width.....	4-1/4 in.
End Table Thickness.....	1/2 in.
End Table Travel.....	3-1/2 in.

**Platen Information**

Platen Type.....	Graphite Coated
Platen Length.....	29-3/4 in.
Platen Width.....	6-3/4 in.

**Construction**

Table.....	Precision-Ground Cast Iron
Frame.....	Steel
Base.....	Steel
Drive Roller.....	Aluminum
Idler Roller.....	Rubber
Miter Block.....	Aluminum
Paint Type/Finish.....	Powder Coated

**Other Related Information**

Number of Dust Ports.....	1
Dust Port Size.....	4 in.
Belt Release.....	Quick Release
Drive Roller Size.....	4-1/4 in.
Idler Roller Size.....	3-3/8 in.

**Other Specifications:**

Country of Origin .....	Taiwan
Warranty .....	1 Year
Approximate Assembly & Setup Time .....	30 Minutes
Serial Number Location .....	ID Label on Top of Sanding Belt Cover
ISO 9001 Factory .....	Yes
Certified by a Nationally Recognized Testing Laboratory (NRTL) .....	No

**Features:**

- Quick Belt Release Lever
- Conveniently Located Belt Tracking and Tension Adjustment
- Handwheel Table Height Adjustment
- Includes Built-in Dust Hood and Miter Block
- Paddle Switch with Safety Key
- Powder Coated Finish



# SECTION 1: SAFETY

## For Your Own Safety, Read Instruction Manual Before Operating This Machine

The purpose of safety symbols is to attract your attention to possible hazardous conditions. This manual uses a series of symbols and signal words intended to convey the level of importance of the safety messages. The progression of symbols is described below. Remember that safety messages by themselves do not eliminate danger and are not a substitute for proper accident prevention measures. Always use common sense and good judgment.



Indicates an imminently hazardous situation which, if not avoided, **WILL** result in death or serious injury.



Indicates a potentially hazardous situation which, if not avoided, **COULD** result in death or serious injury.



Indicates a potentially hazardous situation which, if not avoided, **MAY** result in minor or moderate injury. It may also be used to alert against unsafe practices.

**NOTICE**

Alerts the user to useful information about proper operation of the machine to avoid machine damage.

## Safety Instructions for Machinery

### **WARNING**

**OWNER'S MANUAL.** Read and understand this owner's manual **BEFORE** using machine.

**TRAINED OPERATORS ONLY.** Untrained operators have a higher risk of being hurt or killed. Only allow trained/supervised people to use this machine. When machine is not being used, disconnect power, remove switch keys, or lock-out machine to prevent unauthorized use—especially around children. Make your workshop kid proof!

**DANGEROUS ENVIRONMENTS.** Do not use machinery in areas that are wet, cluttered, or have poor lighting. Operating machinery in these areas greatly increases the risk of accidents and injury.

**MENTAL ALERTNESS REQUIRED.** Full mental alertness is required for safe operation of machinery. Never operate under the influence of drugs or alcohol, when tired, or when distracted.

**ELECTRICAL EQUIPMENT INJURY RISKS.** You can be shocked, burned, or killed by touching live electrical components or improperly grounded machinery. To reduce this risk, only allow qualified service personnel to do electrical installation or repair work, and always disconnect power before accessing or exposing electrical equipment.

**DISCONNECT POWER FIRST.** Always disconnect machine from power supply **BEFORE** making adjustments, changing tooling, or servicing machine. This prevents an injury risk from unintended startup or contact with live electrical components.

**EYE PROTECTION.** Always wear ANSI-approved safety glasses or a face shield when operating or observing machinery to reduce the risk of eye injury or blindness from flying particles. Everyday eyeglasses are **NOT** approved safety glasses.



# WARNING

**WEARING PROPER APPAREL.** Do not wear loose clothing, gloves, neckties, or jewelry that can become entangled in moving parts. Always tie back or cover long hair. Wear non-slip footwear to reduce risk of slipping and losing control or accidentally contacting cutting tool or moving parts.

**HAZARDOUS DUST.** Dust created by machinery operations may cause cancer, birth defects, or long-term respiratory damage. Be aware of dust hazards associated with each workpiece material. Always wear a NIOSH-approved respirator to reduce your risk.

**HEARING PROTECTION.** Always wear hearing protection when operating or observing loud machinery. Extended exposure to this noise without hearing protection can cause permanent hearing loss.

**REMOVE ADJUSTING TOOLS.** Tools left on machinery can become dangerous projectiles upon startup. Never leave chuck keys, wrenches, or any other tools on machine. Always verify removal before starting!

**USE CORRECT TOOL FOR THE JOB.** Only use this tool for its intended purpose—do not force it or an attachment to do a job for which it was not designed. Never make unapproved modifications—modifying tool or using it differently than intended may result in malfunction or mechanical failure that can lead to personal injury or death!

**AWKWARD POSITIONS.** Keep proper footing and balance at all times when operating machine. Do not overreach! Avoid awkward hand positions that make workpiece control difficult or increase the risk of accidental injury.

**CHILDREN & BYSTANDERS.** Keep children and bystanders at a safe distance from the work area. Stop using machine if they become a distraction.

**GUARDS & COVERS.** Guards and covers reduce accidental contact with moving parts or flying debris. Make sure they are properly installed, undamaged, and working correctly BEFORE operating machine.

**FORCING MACHINERY.** Do not force machine. It will do the job safer and better at the rate for which it was designed.

**NEVER STAND ON MACHINE.** Serious injury may occur if machine is tipped or if the cutting tool is unintentionally contacted.

**STABLE MACHINE.** Unexpected movement during operation greatly increases risk of injury or loss of control. Before starting, verify machine is stable and mobile base (if used) is locked.

**USE RECOMMENDED ACCESSORIES.** Consult this owner's manual or the manufacturer for recommended accessories. Using improper accessories will increase the risk of serious injury.

**UNATTENDED OPERATION.** To reduce the risk of accidental injury, turn machine **OFF** and ensure all moving parts completely stop before walking away. Never leave machine running while unattended.

**MAINTAIN WITH CARE.** Follow all maintenance instructions and lubrication schedules to keep machine in good working condition. A machine that is improperly maintained could malfunction, leading to serious personal injury or death.

**DAMAGED PARTS.** Regularly inspect machine for damaged, loose, or mis-adjusted parts—or any condition that could affect safe operation. Immediately repair/replace BEFORE operating machine. For your own safety, DO NOT operate machine with damaged parts!

**MAINTAIN POWER CORDS.** When disconnecting cord-connected machines from power, grab and pull the plug—NOT the cord. Pulling the cord may damage the wires inside. Do not handle cord/plug with wet hands. Avoid cord damage by keeping it away from heated surfaces, high traffic areas, harsh chemicals, and wet/damp locations.

**EXPERIENCING DIFFICULTIES.** If at any time you experience difficulties performing the intended operation, stop using the machine! Contact our Technical Support at (570) 546-9663.



# Additional Safety for Edge Sanders

## **WARNING**

**Serious injury or death can occur if fingers, clothing, jewelry, or hair get entangled in moving components. Impact injuries can occur from kickback if workpiece is improperly fed into moving sandpaper. Serious pinch injuries can occur from touching in-running nip point between table and sanding surface. Long-term respiratory damage can occur from using sander without proper use of a respirator. To reduce the risk of these hazards, operator and bystanders MUST completely heed the hazards and warnings below.**

**AVOIDING ENTANGLEMENT.** Becoming entangled in moving parts of this machine can cause pinching and crushing injuries. To avoid these hazards, DO NOT wear loose clothing, gloves, or jewelry, and tie back long hair. Keep all guards in place and secure.

**IN-RUNNING NIP POINTS.** The gap between moving sandpaper and fixed table/support creates a pinch point for fingers or workpieces; the larger this gap is, the greater risk of fingers or workpieces getting caught in it. Minimize this risk by adjusting table no more than  $\frac{1}{16}$ " away from sandpaper.

**SANDPAPER DIRECTION.** Feeding workpiece incorrectly can cause it to be thrown from machine, striking operator or bystanders, or causing your hands to slip into the moving sandpaper. To reduce these risks, only sand against direction of sandpaper travel, ensure workpiece is properly supported, and avoid introducing sharp edges into moving sandpaper on leading side of workpiece.

**WORKPIECE SUPPORT & HAND PLACEMENT.** Rotating sandpaper can remove a large amount of skin quickly, and kickback can occur with violent force if workpiece is not properly supported during operation. Always sand with workpiece firmly against table or another support device. Never touch moving sandpaper on purpose.

**WORKPIECE INTEGRITY.** Only sand solid workpieces that can withstand power sanding forces. Make sure shape of workpiece is properly supported on table; avoid sanding workpieces without flat bottom surfaces unless some type of jig is used to maintain support and control when sanding force is applied.

**FEEDING WORKPIECE.** Forcefully jamming workpiece into sanding surface could cause workpiece to be aggressively grabbed and pull your hands into sanding surface. Firmly grasp workpiece in both hands and ease it into sandpaper using light pressure.

**SMALL WORKPIECES.** Small workpieces are difficult to control and require close support near sanding surface. Always use a jig or other holding device when sanding small workpieces, and keep hands and fingers at least 2" away from sanding surface.

**WORKPIECE INSPECTION.** Nails, staples, knots, or other imperfections in workpiece can be dislodged and thrown from sander at high rate of speed into operator or bystanders, or cause damage to sandpaper or sander. Never try to sand stock that has embedded foreign objects or questionable imperfections.

**SANDPAPER CONDITION.** Worn or damaged sandpaper not only produces poor sanding results, but could fly apart, aggressively grab workpiece, and throw debris at the operator. Always inspect sandpaper before operation and replace if worn or damaged.

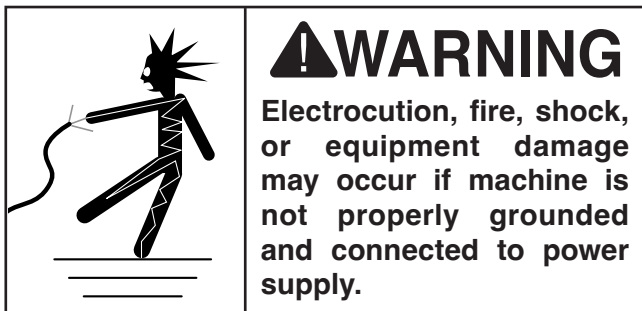
**SANDING DUST & DUST COLLECTION.** Sanding creates large amounts of dust and flying particles that can lead to eye injury or respiratory illness. Reduce risk by wearing approved eye and respiratory protection when using sander. Never operate without adequate dust-collection system in place and running. Proper dust collection reduces dust in work area, decreasing risk of long-term respiratory damage, but it is not a substitute for using a respirator.



# SECTION 2: POWER SUPPLY

## Availability

Before installing the machine, consider the availability and proximity of the required power supply circuit. If an existing circuit does not meet the requirements for this machine, a new circuit must be installed. To minimize the risk of electrocution, fire, or equipment damage, installation work and electrical wiring must be done by an electrician or qualified service personnel in accordance with all applicable codes and standards.



## Full-Load Current Rating

The full-load current rating is the amperage a machine draws at 100% of the rated output power. On machines with multiple motors, this is the amperage drawn by the largest motor or sum of all motors and electrical devices that might operate at one time during normal operations.

**Full-Load Current Rating at 220V ..... 10 Amps**

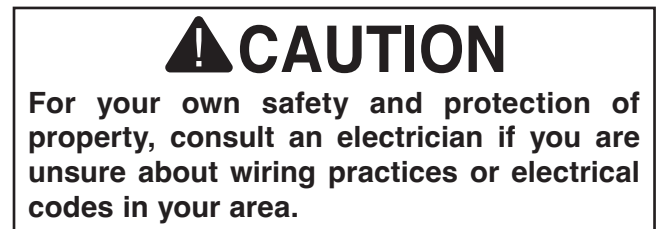
**Full-Load Current Rating at 110V ..... 20 Amps**

The full-load current is not the maximum amount of amps that the machine will draw. If the machine is overloaded, it will draw additional amps beyond the full-load rating.

If the machine is overloaded for a sufficient length of time, damage, overheating, or fire may result—especially if connected to an undersized circuit. To reduce the risk of these hazards, avoid overloading the machine during operation and make sure it is connected to a power supply circuit that meets the specified circuit requirements.

## Circuit Information

A power supply circuit includes all electrical equipment between the breaker box or fuse panel in the building and the machine. The power supply circuit used for this machine must be sized to safely handle the full-load current drawn from the machine for an extended period of time. (If this machine is connected to a circuit protected by fuses, use a time delay fuse marked D.)

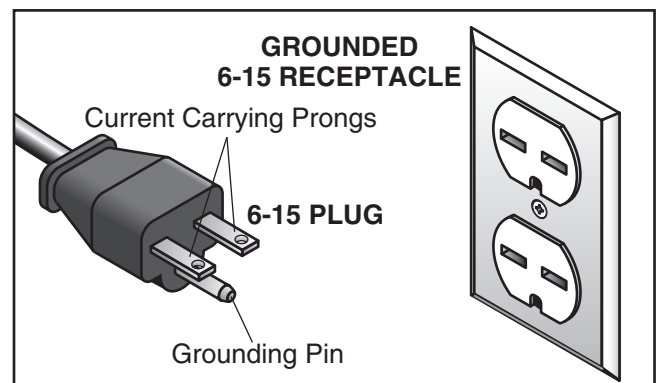


**Note:** *Circuit requirements in this manual apply to a dedicated circuit—where only one machine will be running on the circuit at a time. If machine will be connected to a shared circuit where multiple machines may be running at the same time, consult an electrician or qualified service personnel to ensure circuit is properly sized for safe operation.*

## Circuit Requirements for 220V

This machine is prewired to operate on a power supply circuit that has a verified ground and meets the following requirements:

Nominal Voltage .....	220V
Cycle .....	60 Hz
Phase .....	Single-Phase
Power Supply Circuit .....	15 Amps
Plug/Receptacle .....	NEMA 6-15



**Figure 2.** NEMA 6-15 plug and receptacle.



## Circuit Requirements for 110V

This machine can be converted to operate on a 110V power supply (refer to **Voltage Conversion** instructions) that has a verified ground and meets the following requirements:

**Nominal Voltage** ..... 110V  
**Cycle** ..... 60 Hz  
**Phase** ..... Single-Phase  
**Power Supply Circuit** ..... 30 Amps  
**Plug/Receptacle** ..... NEMA L5-30

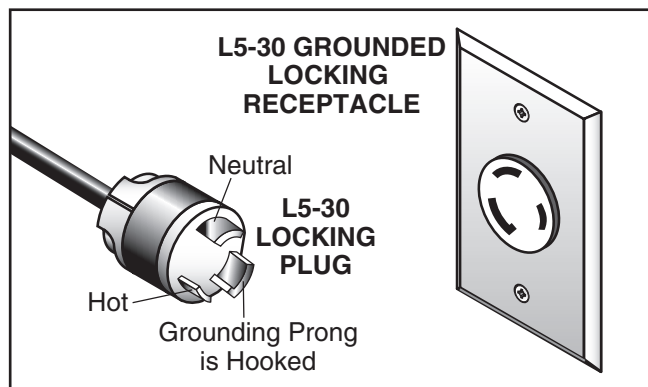


Figure 3. Typical L5-30 plug and receptacle.

## Grounding Requirements

This machine **MUST** be grounded. In the event of certain malfunctions or breakdowns, grounding reduces the risk of electric shock by providing a path of least resistance for electric current.

This machine is equipped with a power cord that has an equipment-grounding wire and a grounding plug. Only insert plug into a matching receptacle (outlet) that is properly installed and grounded in accordance with all local codes and ordinances. **DO NOT** modify the provided plug!

Improper connection of the equipment-grounding wire can result in a risk of electric shock. The wire with green insulation (with or without yellow stripes) is the equipment-grounding wire. If repair or replacement of the power cord or plug is necessary, do not connect the equipment-grounding wire to a live (current carrying) terminal.

Check with a qualified electrician or service personnel if you do not understand these grounding requirements, or if you are in doubt about whether the machine is properly grounded. If you ever notice that a cord or plug is damaged or worn, disconnect it from power, and immediately replace it with a new one.

**⚠ WARNING**

Serious injury could occur if you connect machine to power before completing setup process. **DO NOT** connect to power until instructed later in this manual.

**⚠ CAUTION**

No adapter should be used with plug. If plug does not fit available receptacle, or if machine must be reconnected for use on a different type of circuit, reconnection must be performed by an electrician or qualified service personnel, and it must comply with all local codes and ordinances.

## Extension Cords

We do not recommend using an extension cord with this machine. If you must use an extension cord, only use it if absolutely necessary and only on a temporary basis.

Extension cords cause voltage drop, which can damage electrical components and shorten motor life. Voltage drop increases as the extension cord size gets longer and the gauge size gets smaller (higher gauge numbers indicate smaller sizes).

Any extension cord used with this machine must be in good condition and contain a ground wire and matching plug/receptacle. Additionally, it must meet the following size requirements:

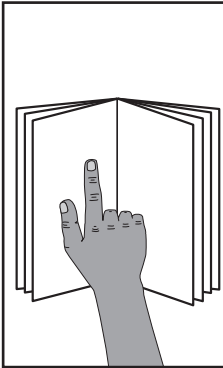
**Minimum Gauge Size** ..... 12 AWG  
**Maximum Length (Shorter is Better)** ..... 50 ft.

## Voltage Conversion

The voltage conversion **MUST** be performed by a qualified electrician. To perform the voltage conversion, install the correct plug and rewire the motor to the new voltage, according to the provided wiring diagram. *If the diagram included on the motor conflicts with the one in this manual, the motor may have changed since the manual was printed. Use the diagram provided on the motor.*

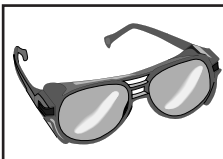


# SECTION 3: SETUP



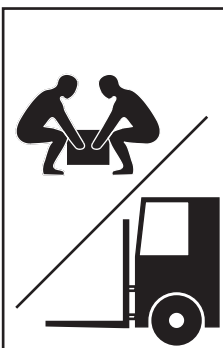
## **!WARNING**

This machine presents serious injury hazards to untrained users. Read through this entire manual to become familiar with the controls and operations before starting the machine!



## **!WARNING**

Wear safety glasses during the entire setup process!



## **!WARNING**

### HEAVY LIFT!

Straining or crushing injury may occur from improperly lifting machine or some of its parts. To reduce this risk, get help from other people and use a forklift (or other lifting equipment) rated for weight of this machine.

## **!WARNING**

No list of safety guidelines can be complete. Every shop environment is different. Always consider safety first, as it applies to your individual working conditions. Use this and other machinery with caution and respect. Failure to do so could result in serious personal injury, damage to equipment, or poor work results.

## Needed for Setup

The following items are needed, but not included, for the setup/assembly of this machine.

Description	Qty
• Straightedge 4' .....	1
• Safety Glasses .....	1 Per Person
• Lifting Assistant .....	1
• Dust Collection System .....	1
• 4" Dust Hose & Clamp .....	1
• Open-End Wrench/Socket 12mm.....	1
• Open-End Wrench/Socket 14mm.....	1
• Open-End Wrench 19mm.....	1
• Phillips Head Screwdriver #2 .....	1
• Hex Wrench 1/8" or 3/16" .....	1
• Hex Wrench 4mm.....	1

## Unpacking

This machine was carefully packaged for safe transport. When unpacking, separate all enclosed items from packaging materials and inspect them for shipping damage. ***If items are damaged, please call us immediately at (570) 546-9663.***

**IMPORTANT:** Save all packaging materials until you are completely satisfied with the machine and have resolved any issues between Grizzly or the shipping agent. *You MUST have the original packaging to file a freight claim. It is also extremely helpful if you need to return your machine later.*



# Inventory

The following is a list of items shipped with your machine. Before beginning setup, lay these items out and inventory them.

If any non-proprietary parts are missing (e.g. a nut or a washer), we will gladly replace them; or for the sake of expediency, replacements can be obtained at your local hardware store.

<b>Box 1 (Figures 4–5)</b>	<b>Qty</b>
<b>A.</b> Sanding Unit.....	1
<b>B.</b> Work Table .....	1
<b>C.</b> Trunnions.....	2
<b>D.</b> Leadscrew Bracket.....	1
<b>E.</b> Sanding Belt 6" x 80" .....	1
<b>F.</b> Table Bracket w/Leadscrew .....	1
<b>G.</b> Dust Hood .....	1
<b>H.</b> End Table .....	1
<b>I.</b> End Table Post.....	1
<b>J.</b> Idler Roller Guard.....	1
<b>K.</b> Miter Gauge.....	1
<b>L.</b> Lock Knob $\frac{5}{16}$ "-18.....	1
<b>M.</b> Back Stop (G1140 Only) .....	1
<b>N.</b> Lock Handles $\frac{3}{8}$ "-16 x 1" .....	3
<b>O.</b> Feet .....	4
<b>P.</b> Horizontal Brace.....	1
<b>Q.</b> Vertical Brace.....	1
<b>R.</b> Tension Lever.....	1

## Fasteners (and where installed)

- Phillips Head Screws 10-24 x  $\frac{3}{4}$ " (Feet) .... 4
- Hex Nut  $\frac{1}{2}$ "-13 (Tension Lever) ..... 1
- Hex Bolts  $\frac{5}{16}$ "-18 x  $\frac{1}{2}$ " (Dust Hood) ..... 2
- Flat Washers  $\frac{5}{16}$ " (Dust Hood)..... 2
- Lock Knob  $\frac{1}{4}$ "-20 (Idler Roller Guard)..... 1
- Flat Washer  $\frac{1}{4}$ " (Idler Roller Guard)..... 1
- Hex Bolts  $\frac{3}{8}$ "-16 x 1" (Leadscrew Bracket) 4
- Lock Washers  $\frac{3}{8}$ " (Leadscrew Bracket).... 4
- Flat Washers  $\frac{3}{8}$ " (Lock Handles) ..... 3
- Hex Nut  $\frac{1}{2}$ "-13 (Horizontal Brace) ..... 1
- Hex Bolt  $\frac{5}{16}$ "-18 x  $\frac{1}{2}$ " (Horizontal Brace).... 1
- Hex Nuts  $\frac{1}{2}$ "-13 (Vertical Brace) ..... 2
- Flat Washers  $\frac{1}{2}$ "-13 (Vertical Brace)..... 2
- Hex Bolts  $\frac{5}{16}$ "-18 x 1" (Trunnions) ..... 2
- Flat Washers  $\frac{5}{16}$ " (Trunnions) ..... 2
- Flat Washer  $\frac{5}{16}$ " (Miter Gauge) ..... 1

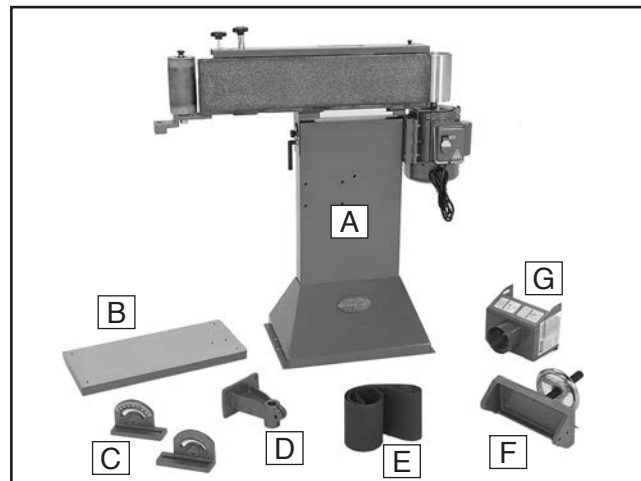


Figure 4. Inventory 1.

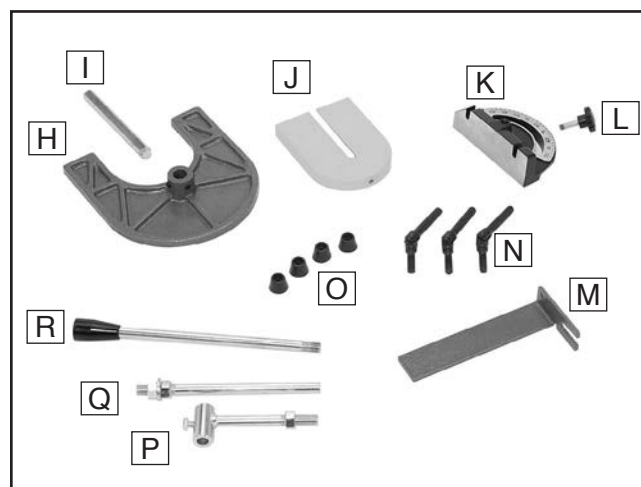


Figure 5. Inventory 2.


## NOTICE

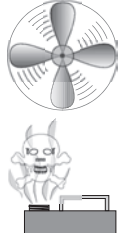
If you cannot find an item on this list, carefully check around/inside the machine and packaging materials. Often, these items get lost in packaging materials while unpacking or they are pre-installed at the factory.



# Cleanup

The unpainted surfaces are coated with a waxy oil to prevent corrosion during shipment. Remove this protective coating with a solvent cleaner or degreaser, such as shown in **Figure 6**. For thorough cleaning, some parts must be removed. **For optimum performance, clean all moving parts or sliding contact surfaces.** Avoid chlorine-based solvents, such as acetone or brake parts cleaner that may damage painted surfaces. Always follow the manufacturer's instructions when using any type of cleaning product.

	<p><b>! WARNING</b> Gasoline and petroleum products have low flash points and can explode or cause fire if used to clean machinery. <b>DO NOT</b> use these products to clean the machinery.</p>
---	--

	<p><b>! CAUTION</b> Many cleaning solvents are toxic if inhaled. Minimize your risk by only using these products in a well ventilated area.</p>
---	---

## T23692—Orange Power Degreaser

A great product for removing the waxy shipping grease from the *non-painted* parts of the machine during clean up.

<p><b>Order online at</b> <a href="http://www.grizzly.com">www.grizzly.com</a> <b>OR</b> <b>Call 1-800-523-4777</b></p>	
---	---

**Figure 6.** T23692 Orange Power Degreaser.

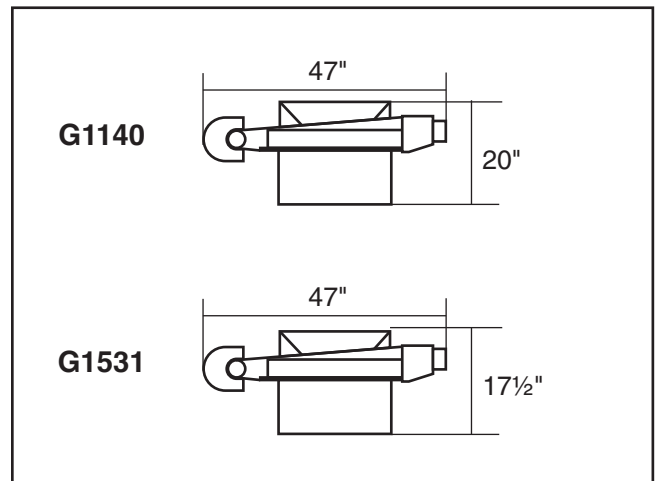
# Site Considerations

## Floor Load

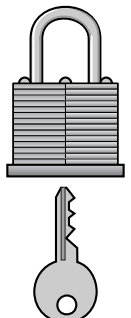
Refer to the **Machine Data Sheet** for the weight and footprint specifications of your machine. Some residential floors may require additional reinforcement to support both the machine and operator.

## Placement Location

Consider existing and anticipated needs, size of material to be processed through each machine, and space for auxiliary stands, work tables or other machinery when establishing a location for your new machine. See **Figure 7** for the minimum working clearances.



**Figure 7.** Minimum working clearances.

	<p><b>! CAUTION</b> Children and visitors may be seriously injured if unsupervised around this machine. Lock entrances to the shop or disable start switch or power connection to prevent unsupervised use.</p>
--	---



# Assembly

The machine must be fully assembled before it can be operated. Before beginning the assembly process, refer to **Needed for Setup** and gather all listed items. To ensure the assembly process goes smoothly, first clean any parts that are covered or coated in heavy-duty rust preventative (if applicable).

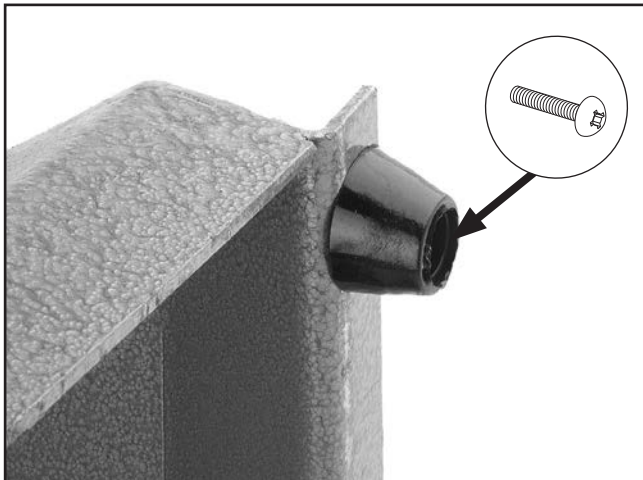
## To assemble your edge sander:

1. With the help of an assistant, carefully lay the machine on its side.

### **!WARNING**

**Serious personal injury could occur if you try to lay the machine over by yourself.**

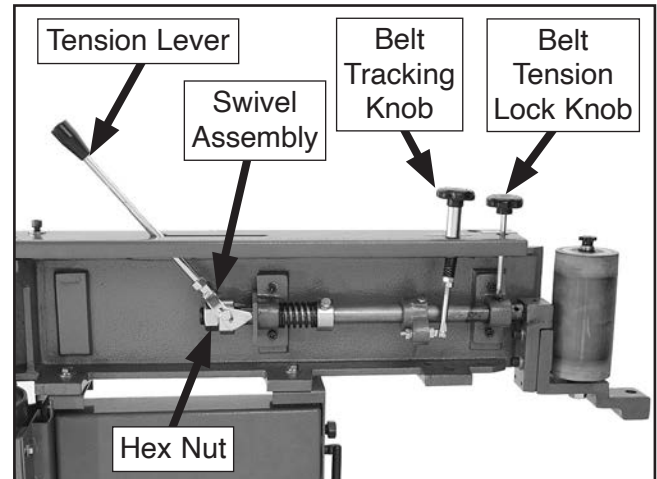
2. Install the four feet in the bottom of the base using the four 10-24 x  $\frac{3}{4}$ " Phillips head screws (**Figure 8**), then stand the machine upright.



**Figure 8.** Foot installed.

3. Loosen the belt tension lock knob.

4. Thread a  $\frac{1}{2}$ -13 hex nut onto the tension lever, slide the tension lever through the slot on the top of the platen cover, then thread it into the swivel assembly (see **Figure 9**). It may be necessary to have an assistant push the idler roller back into the machine to allow the tension lever to line up with the thread in the yoke.

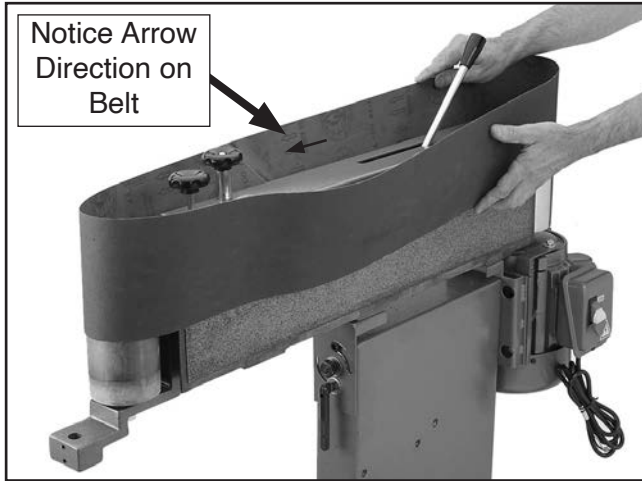


**Figure 9.** Tension lever installed.

5. Tighten the hex nut against the swivel assembly to secure the tension lever.

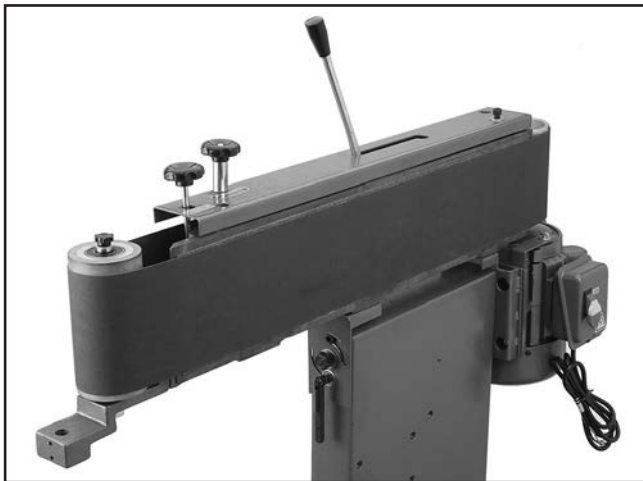


- Loosen the belt tension lock knob, and move the tension lever to the release position, as shown in **Figure 10**.



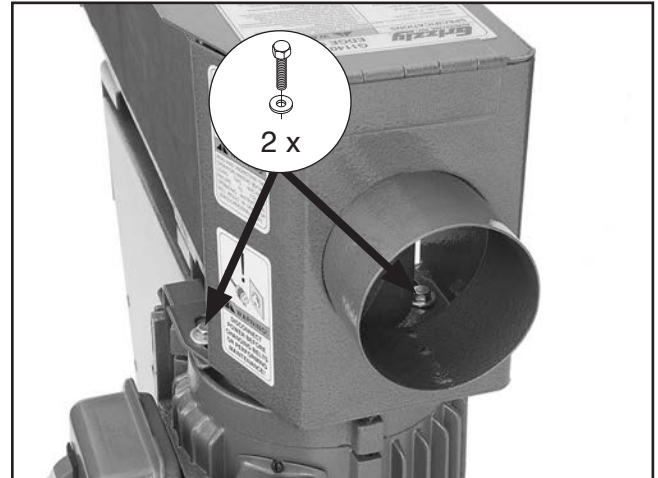
**Figure 10.** Installing sanding belt.

- Make sure the arrows on the inside of the belt point in the counterclockwise direction, and place the sanding belt over both rollers as shown in **Figure 10** above.
- Move the tension lever back to its tensioned position, as shown in **Figure 11**. Belt pre-tracking and tracking are covered on **Pages 18 and 19**.



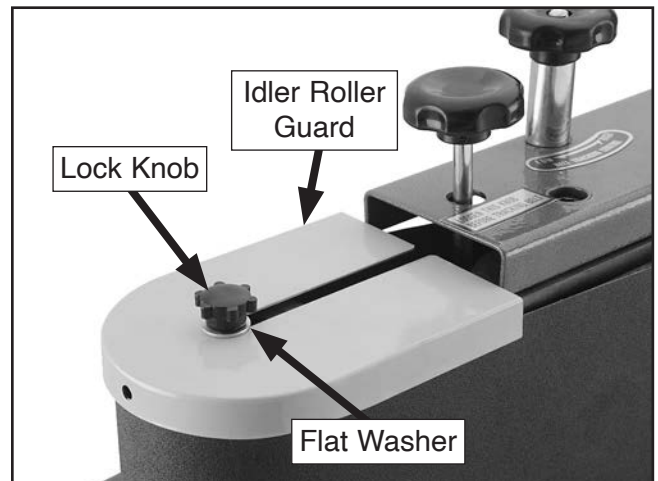
**Figure 11.** Sanding belt installed.

- Position the dust hood approximately 1" away from the main roller and fasten to the sander using the two pre-installed  $\frac{5}{16}$ "-18 hex bolts and flat washers, as shown in **Figure 12**.



**Figure 12.** Dust hood installed.

- Install the idler roller guard onto the left end of the sander with the pre-installed  $\frac{1}{4}$ "-20 lock knob and  $\frac{1}{4}$ " flat washer, as shown in **Figure 13**.



**Figure 13.** Idler roller guard installed.



# Pre-Tracking Belt

You must perform the following procedure before performing the test run to ensure that the belt does not come off of or bottom out on the rollers during the initial startup.

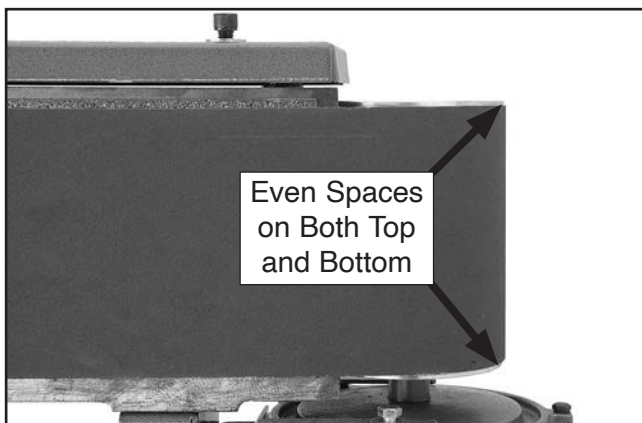
## To pre-track the belt:

1. DISCONNECT SANDER FROM POWER!
2. Loosen the belt tension lock knob.
3. Move the tension lever to the tensioned position.

## ⚠ CAUTION

Sanding surfaces can cause serious personal injury if they come in contact with fingers, hands or other body parts. To reduce the risk of injury, wear gloves during the next step.

4. Standing in front of the sander, push the sanding belt multiple times along the platen, so that it moves in the direction of operation (counterclockwise on the rollers), and watch how the belt tracks on the rollers.
5. Adjust the tracking higher or lower with the belt tracking knob as needed and continue to rotate the belt by hand until the sanding belt is centered on the main roller, as shown in **Figure 14**.



**Figure 14.** Example of sanding belt centered on main roller (dust hood removed for clarity).

6. Tighten the belt tension lock knob.

# Test Run & Tracking Belt

Once assembly is complete, test run the machine to ensure it is properly connected to power and safety components are functioning correctly.

If you find an unusual problem during the test run, immediately stop the machine, disconnect it from power, and fix the problem **BEFORE** operating the machine again. The **Troubleshooting** table in the **SERVICE** section of this manual can help.

The Test Run consists of verifying the following: 1) The motor powers up and runs correctly, 2) the belt tracks correctly, 3) the safety disabling mechanism on the switch works correctly.

You must perform the pre-tracking procedure on **this page** before starting the sander to ensure that the belt does not come off of or bottom out on the rollers during startup.

## ⚠ WARNING

Serious injury or death can result from using this machine **BEFORE** understanding its controls and related safety information. **DO NOT** operate, or allow others to operate, machine until the information is understood.

## ⚠ WARNING

**DO NOT** start machine until all preceding setup instructions have been performed. Operating an improperly set up machine may result in malfunction or unexpected results that can lead to serious injury, death, or machine/property damage.



**To test run the machine and track the belt:**

1. Clear all setup tools away from machine.
2. Make sure the belt is properly pre-tracked (refer to **Pre-Tracking Belt** on **Page 18**).
3. Connect the machine to the power source.
4. Turn machine **ON**, verify motor operation, and then turn machine **OFF**.

The motor should run smoothly and without unusual problems or noises.

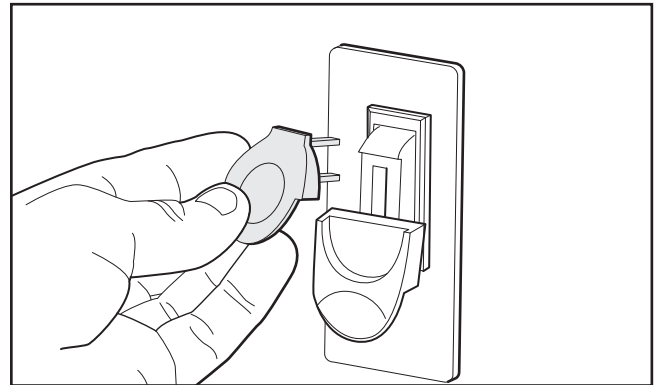
**⚠ CAUTION**

Moving sanding belts are dangerously abrasive. Use extreme caution when working near sanding surfaces. Use extreme caution while making adjustments that require momentary or extended operation of the edge sander. Failure to exercise care while sanding could result in severe personal injury.

5. Loosen the belt tension lock knob, and using the tracking control knob, carefully adjust the tracking higher or lower until the sanding belt remains centered on the main roller (see **Figure 14**).

**Note:** *The tracking control knob is very sensitive; adjust it carefully in small increments.*

6. When the tracking is correct, allow the sander to run for approximately one minute to verify that the tracking stays in the correct position.
7. Repeat **Steps 5–6** if tracking does not stay correct, otherwise proceed to **Step 8**.
8. When the sanding belt is tracking correctly, tighten the belt tension lock knob.
9. Turn the machine **OFF**, and remove the switch disabling key, as shown in **Figure 15**.



**Figure 15.** Removing switch key from paddle switch.

10. Try to start machine with paddle switch. The machine should not start.
  - If the machine *does not* start, the switch disabling feature is working as designed.
  - If the machine *does start*, immediately stop the machine. The switch disabling feature is not working correctly. This safety feature must work properly before proceeding with regular operations. Call Tech Support for help.



# Installing Work Table

## To install the work table:

1. DISCONNECT SANDER FROM POWER!
2. Attach the leadscrew bracket (Figure 16) to the front of the stand using the four pre-installed  $\frac{3}{8}$ "-16 x 1" hex bolts and lock washers, then install the lock handle with the thin  $\frac{3}{8}$ " flat washer.

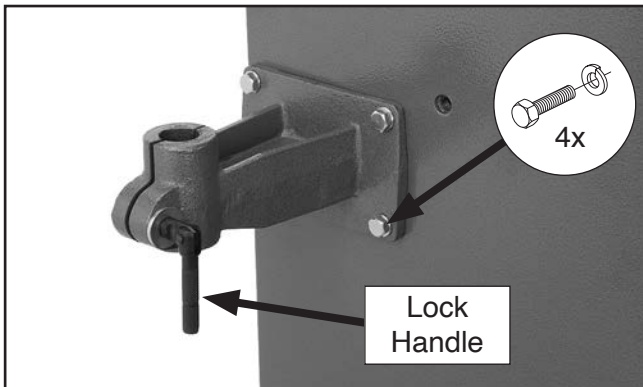


Figure 16. Leadscrew bracket installed.

3. Thread a  $\frac{1}{2}$ "-13 hex nut  $\frac{3}{4}$  of the way onto the horizontal brace, and thread a  $\frac{5}{16}$ "-18 x  $\frac{1}{2}$ " hex bolt into the shaft on the horizontal brace (Figure 17), making sure the bolt end is flush with the inside of the shaft.

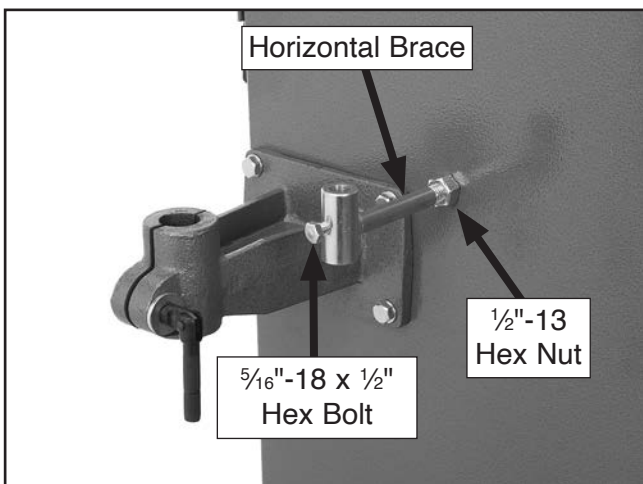


Figure 17. Horizontal brace installed.

4. Thread the horizontal brace into the sander (Figure 17), but do not tighten the hex nut yet; the brace will require further adjustment later.

5. Rotate the handwheel so it is in the center of the leadscrew, then insert the leadscrew assembly into the leadscrew bracket, as shown in Figure 18. Position the leadscrew assembly so the red pointer is on the left side.

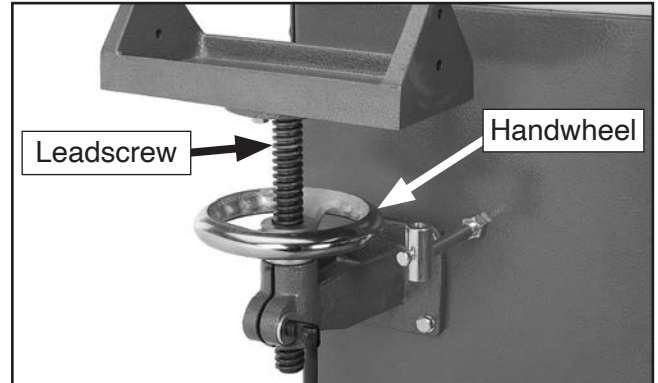


Figure 18. Leadscrew assembly installed.

6. Turn the horizontal brace approximately  $45^\circ$ .
7. Install a  $\frac{1}{2}$ "-13 hex nut and flat washer onto the vertical brace until 1" of the threaded end is visible above the washer.
8. Insert the vertical brace through the shaft at the end of the horizontal brace (Figure 19), then rotate the horizontal/vertical brace assembly to  $90^\circ$ . Do not tighten the fasteners yet.

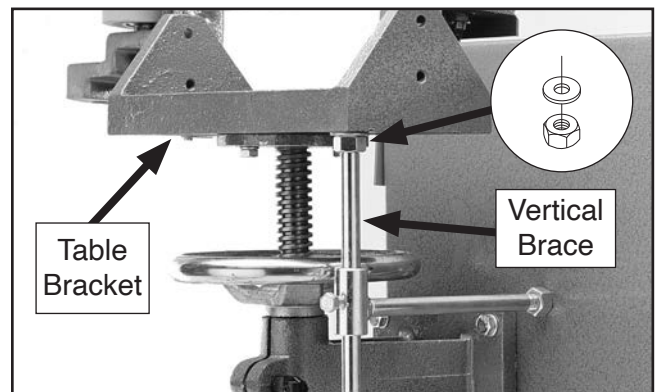
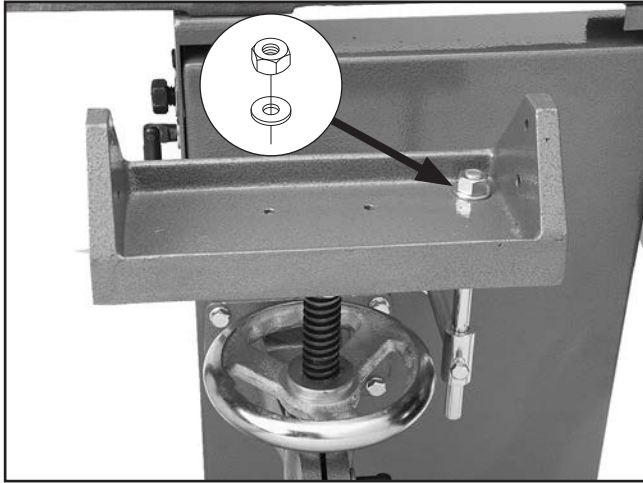


Figure 19. Horizontal/vertical brace installed.

9. Insert the threaded end of the vertical brace through the hole in the bottom of the table bracket.

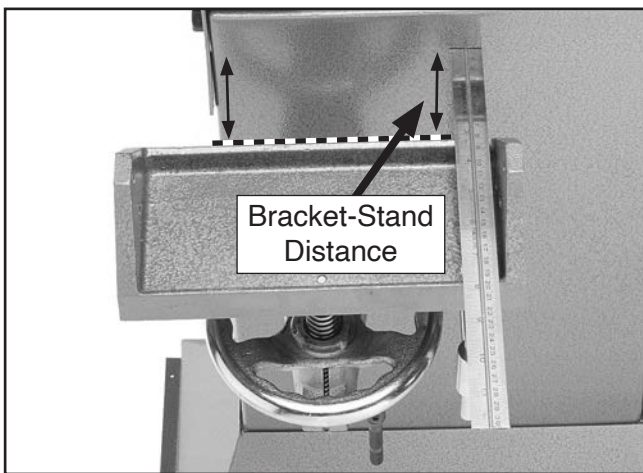


10. Now install a  $\frac{1}{2}$ "-13 hex nut and flat washer onto the shaft end (**Figure 20**). Thread the handwheel down until it touches the top of the leadscrew bracket.



**Figure 20.** Table bracket top secured.

11. Measure the distance between the table bracket and stand, checking that the bracket is parallel to the stand, as shown in **Figure 21**.

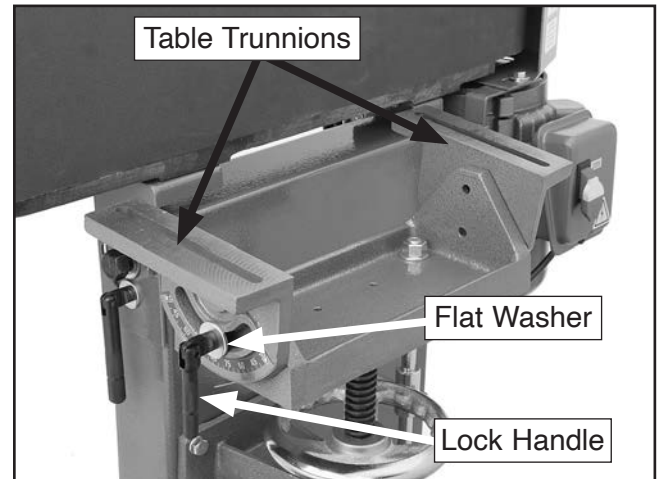


**Figure 21.** Checking table bracket for parallelism.

- If the bracket is not parallel to the stand, loosen the hex nuts on the vertical brace and adjust the table bracket-stand distance until it is equal.
- If the bracket is still not parallel, remove the vertical brace, thread the horizontal brace in or out an appropriate amount, and reinstall the vertical brace. Check the table bracket-stand distance and adjust until it is equal.

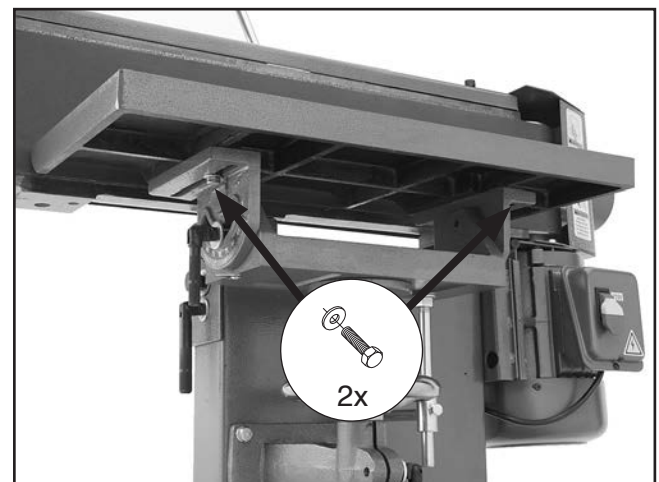
12. Once the table bracket is parallel to the stand, tighten the horizontal brace jam nut and the hex bolt and hex nuts that hold the vertical brace in place.

13. Attach each table trunnion to the table bracket with a  $\frac{3}{8}$ " flat washer and lock handle, as shown in **Figure 22**. The trunnion with the scale attaches to the left side.



**Figure 22.** Table trunnions installed.

14. Leaving the table trunnion lock handles slightly loose, secure the work table to the trunnions using the two  $\frac{5}{16}$ "-18 x 1" hex bolts and  $\frac{5}{16}$ " flat washers, as shown in **Figure 23**. Adjust the table so it is approximately  $\frac{1}{8}$ " to  $\frac{3}{16}$ " from the sanding platen, then tighten the mounting bolts.

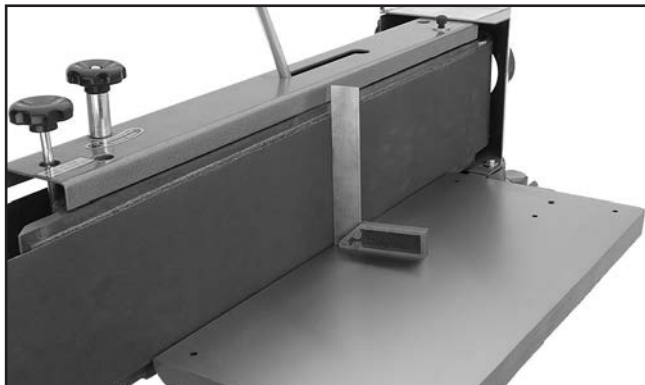


**Figure 23.** Work table installed.

**Note:** You can use an  $\frac{1}{8}$ " or  $\frac{3}{16}$ " hex wrench as a gauge to set the distance between the table and sanding belt.

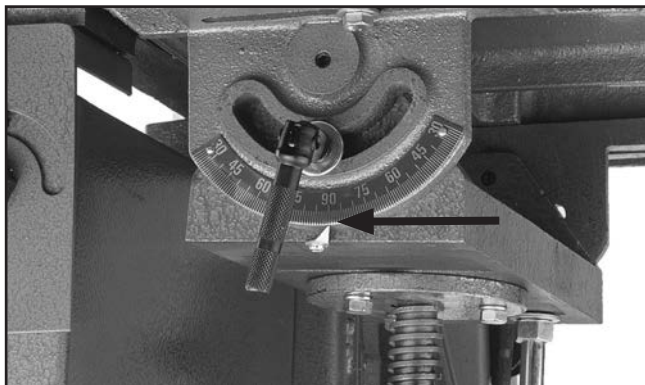


15. Place one edge of a square against the work table and the other against the sanding belt and platen, as shown in **Figure 24**.



**Figure 24.** Squaring main work table.

16. Adjust the work table perpendicular to the sanding platen, tighten the table lock handles, then adjust the pointer to 90° (**Figure 25**).



**Figure 25.** Pointer set to 90°.

17. Set the miter body into its pivot hole and secure into place with the plastic lock knob and 5/16" flat washer, as shown in **Figure 26**. The miter body should only be used when sanding the ends of workpieces at least 8" long. Do not use it as a back stop.

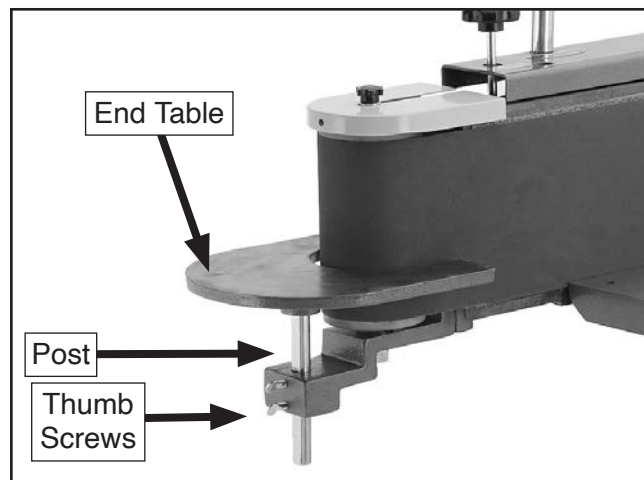


**Figure 26.** Miter gauge installed.

## Installing End Table

To install the end table:

1. DISCONNECT SANDER FROM POWER!
2. Insert the end table post into the bottom of the end table so the flat part of the shaft faces away from the end of the sander, as shown in **Figure 27**.



**Figure 27.** End table installed.

3. Unscrew the thumb screws, slide the end table into place, as shown in **Figure 27**, and tighten the thumb screws when the table is at the desired working height. It is not necessary to have the end table mounted at all times—it can be installed when needed.

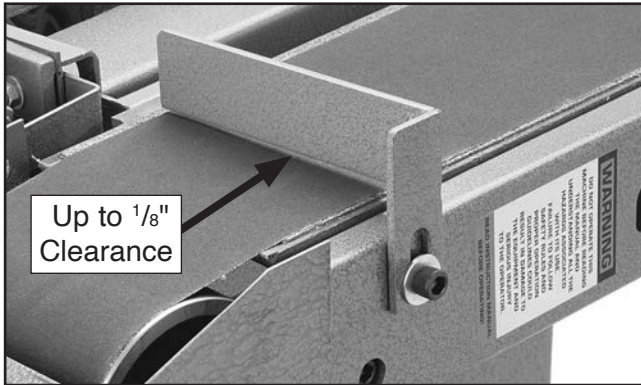
### **NOTICE**

**Make sure tables do not come in contact with rotating sanding belt.**



# Back Stop (G1140)

Attach the back stop with the preinstalled cap screw and flat washer, as shown in **Figure 28**, setting the bottom edge no more than  $\frac{1}{8}$ " from the sandpaper. This will prevent objects from jamming between the back stop and the sanding belt, reducing the risk of a potentially dangerous situation.



**Figure 28.** Back stop installed.

## **!WARNING**

**DO NOT** attempt to operate the Model G1140 without this back stop in place and properly adjusted as described above. An improper gap between the stop and the belt can create a situation where a finger or hand can get trapped against the moving belt, causing serious personal injury.

# Dust Collection

## **!CAUTION**

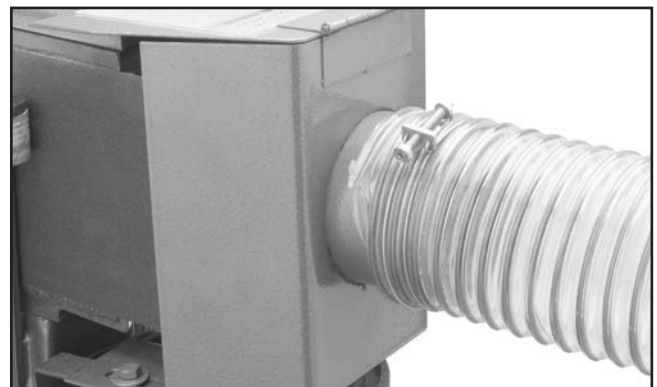
**This machine creates a lot of wood chips/dust during operation. Breathing airborne dust on a regular basis can result in permanent respiratory illness. Reduce your risk by wearing a respirator and capturing the dust with a dust-collection system.**

### **Recommended CFM at Dust Hood: 450**

*Do not confuse this CFM recommendation with the rating of the dust collector. To determine the CFM at the dust port, you must consider these variables: (1) CFM rating of the dust collector, (2) hose type and length between the dust collector and the machine, (3) number of branches or wyes, and (4) amount of other open lines throughout the system. Explaining how to calculate these variables is beyond the scope of this manual. Consult an expert or purchase a good dust collection "how-to" book.*

### **To connect a dust collection hose:**

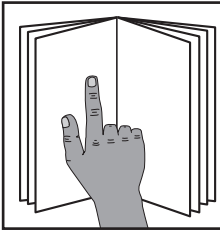
Fit the 4" dust hose over the dust port, and secure it in place with a hose clamp, as shown in **Figure 29**.



**Figure 29.** Example of dust port connected to dust collection system.



# SECTION 4: OPERATIONS

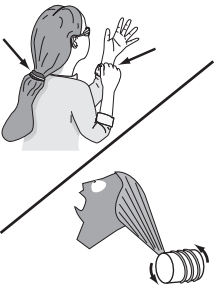
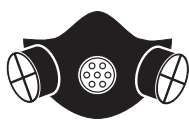


## ⚠️ WARNING

To reduce your risk of serious injury, read this entire manual **BEFORE** using machine.

## ⚠️ WARNING

Eye injuries, respiratory problems, or hearing loss can occur while operating this tool. Wear personal protective equipment to reduce your risk from these hazards.



## ⚠️ WARNING

Keep hair, clothing, and jewelry away from moving parts at all times. Entanglement can result in death, amputation, or severe crushing injuries!

## NOTICE

If you are not experienced with this type of machine, WE STRONGLY RECOMMEND that you seek additional training outside of this manual. Read books/magazines or get formal training before beginning any projects. Regardless of the content in this section, Grizzly Industrial will not be held liable for accidents caused by lack of training.

## Basic Edge Sander Controls

This section covers the basic controls used during routine operation.

**Paddle Switch:** Turns the motor **ON** when flipped up; turns motor **OFF** when pressed down (**Figure 30**).

**Switch Disabling Key:** Disables switch when the yellow key is removed (**Figure 30**).

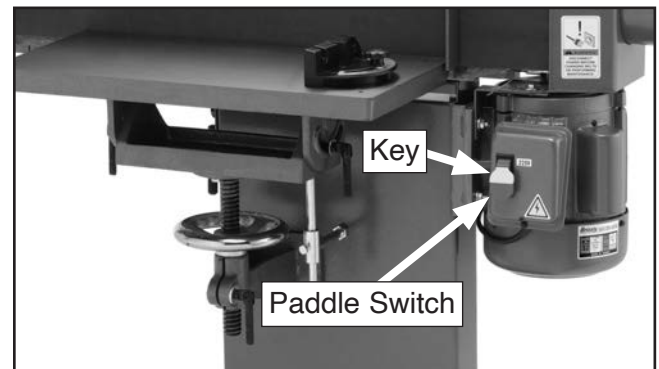


Figure 30. Paddle switch location.

**Table Tilt:** To tilt the table, loosen the trunnion lock handles (**Figure 31**), tilt the work table to the desired angle, then retighten the lock handles.

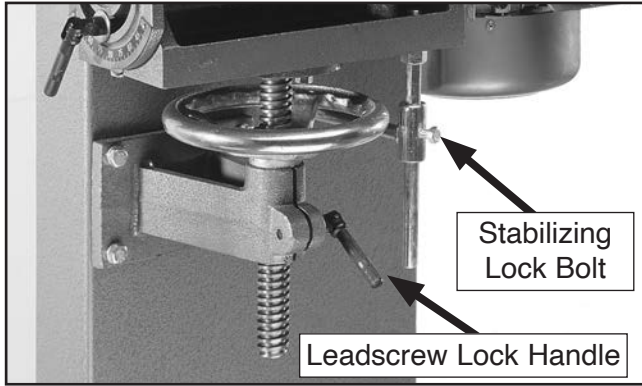


Figure 31. Trunnion lock handles.



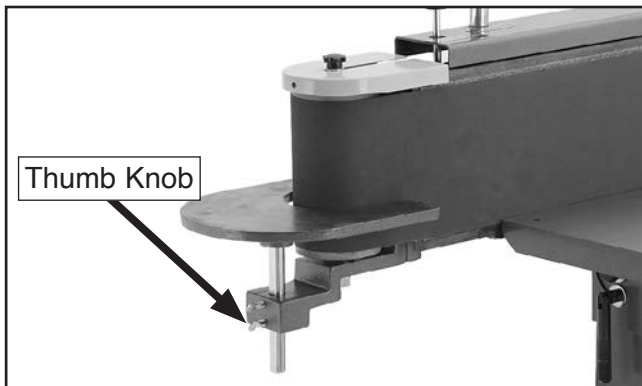
If necessary, re-adjust the work table closer to the platen (refer to **Page 21, Step 13**), aiming for a  $\frac{1}{8}$ " to  $\frac{3}{16}$ " gap between the platen and the work table.

**Table Height:** To adjust table height, loosen lock handle (**Figure 32**) and stabilizing lock bolt. Turn handwheel and position work table to desired height, then retighten lock handle and lock bolt.



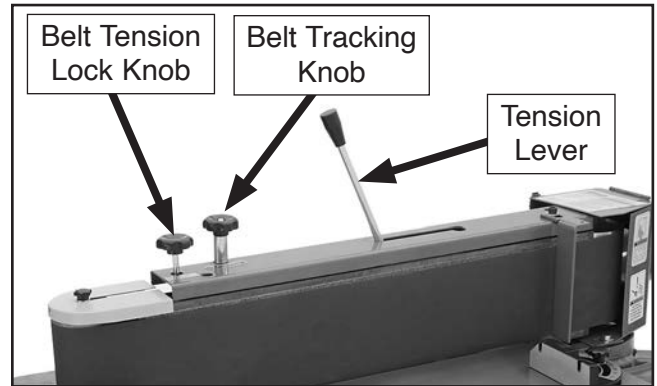
**Figure 32.** Table height controls.

**End Table:** To adjust end table height, loosen the thumb screws, position the table, then re-tighten the thumb screws, as shown in **Figure 33**. When using the end roller for curved sanding, we recommend you use the center portion of the roller to assure proper belt tracking. This also prevents the edge of the workpiece from becoming tapered.



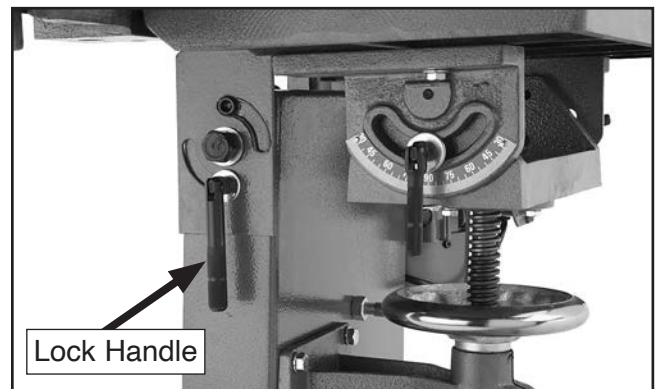
**Figure 33.** End table.

**Belt Tracking and Tension:** To adjust the tracking, loosen the belt tension lock knob, move the tension lever to the closed position, turn the belt tracking knob to adjust the belt height, then tighten the belt tension lock knob.

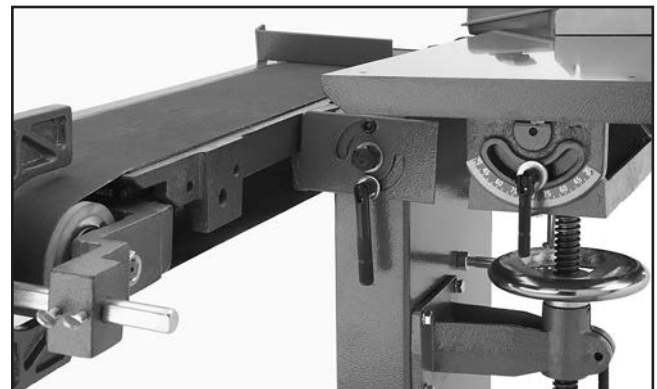


**Figure 34.** Belt tracking and tension controls.

**Platen Tilt (Model G1140 Only):** To tilt the platen, loosen the table tilt lock handle shown in **Figure 35**, carefully tilt the platen assembly (**Figure 36**), then retighten the lock handle. After returning the platen assembly to its upright position tighten the lock handle.



**Figure 35.** Platen tilt lock handle.



**Figure 36.** Platen tilted to 90°.



# Edge & End Sanding

To perform edge or end sanding:

1. Check to make sure the sanding belt is tracking correctly (see **Tracking Belt** on **Page 28**).
2. Turn the sander **ON**.
3. Keep your fingers away from the moving belt and slowly feed the workpiece into the moving belt, as shown in **Figures 37 & 38**.



**Figure 37.** Typical edge sanding method.

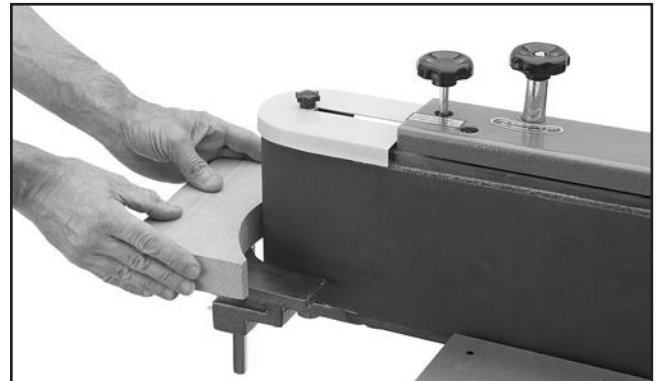


**Figure 38.** Typical end grain sanding method using miter gauge.

# Contour Sanding

To perform contour sanding:

1. Make sure belt tracking is correctly set (see **Tracking Belt** on **Page 28**).
2. Adjust the end table up or down so the workpiece is roughly centered on the roller, then secure it with the thumb knobs.
3. Turn the sander **ON**.
4. While supporting the workpiece against the end table and keeping your fingers away from the belt, slowly feed the workpiece into the curved end and continue moving the workpiece profile along the contour until you achieve your desired shape, as shown in **Figure 39**.



**Figure 39.** Example of contour sanding method.

## **⚠️WARNING**

Do not operate this equipment when wearing loose clothing, gloves, neckties, rings, bracelets or other jewelry which might get caught in the moving belt or trapped between the belt and the tables. Serious personal injury may result.



# Horizontal Sanding (G1140)

## To perform horizontal sanding:

1. Make sure belt tracking is correctly set (see **Tracking Belt** on **Page 28**).
2. Tilt the platen so it is horizontal (see **Page 25**, *Platen Tilt*), then lock it in place.
3. Turn the sander **ON**.
4. While supporting the workpiece against the back stop and keeping your fingers away from the belt, slowly feed the workpiece into the belt, as shown in **Figure 40**.

**Note:** Apply even hand pressure while moving the workpiece back and forth for even belt wear.



**Figure 40.** Example of face sanding method.

## **!**WARNING

Sanding surfaces can cause serious personal injury if they come in contact with fingers, hands or other body parts. Use extreme care to provide a safe distance between the belt and any part of your body.

# Sanding Tips

- Replace the sandpaper with a higher grit to achieve a finer finish.
- Extend the life of the sandpaper by regularly using a PRO-STICK® sanding pad (see **Accessories** on **Page 29**).
- When sanding workpieces with a bow or crown, place the high point up on the table (prevents the workpiece from rocking) and take very light passes.

# Choosing Sandpaper

The Model G1140/G1531 uses a 6" x 80" sanding belt.

There are many types of sanding belts to choose from. We recommend aluminum oxide for general workshop environments. Below is a chart that groups abrasives into different classes, and shows which grits fall into each class.

Grit	Class
36	Extra Coarse
60	Coarse
80–100	Medium
120–180	Fine

The general rule of thumb is to sand a workpiece with progressively higher grit numbers, with no one grit increase of more than 50. Avoid skipping grits; the larger the grit increase, the harder it will be to remove the scratches from the previous grit.

Ultimately, the type of wood you use and your stage of finish will determine the best grit types to install on your sander.

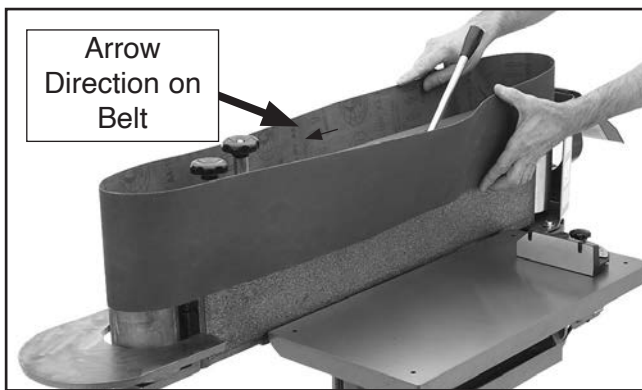


# Replacing Belt

Replace the belt on the Model G1140/G1531 with a 6" x 80" sanding belt. Grizzly carries a wide variety of aluminum oxide sanding belts for your edge sander (refer to **Accessories** on **Page 29**).

**To replace the sanding belt:**

1. DISCONNECT SANDER FROM POWER!
2. Loosen the belt tracking lock knob, then move the tension lever to the release position, as shown in **Figure 41**.



**Figure 41.** Installing the sanding belt.

3. Remove the idler roller guard and the back stop (Model G1140), open the dust port cover, then remove the belt.
4. Make sure the arrows on the inside of the new belt point in the counterclockwise direction, and place the new sanding belt over both rollers, as shown in **Figure 41**.
5. Move the tension lever back to its tensioned position, as shown in **Figure 42**.



**Figure 42.** Sanding belt installed.

6. Close the dust port cover, then reinstall the idler roller guard and back stop (Model G1140).
7. Perform the belt pre-tracking procedure (refer to **Pre-Tracking Belt** on **Page 18**).
8. Perform the belt tracking procedure below.

## Tracking Belt

**To track the belt:**

1. Make sure the belt is properly pre-tracked (refer to **Pre-Tracking Belt** on **Page 18**).
2. Tie back loose clothing and long hair to protect yourself from getting caught in the moving sanding belt when you start the machine.
3. Loosen the belt tension lock knob, turn the sander **ON**, and using the tracking control knob, carefully adjust the tracking higher or lower until the sanding belt remains centered on the main roller (**Figure 14, Page 18**).

**Note:** *The tracking control knob is very sensitive; adjust it carefully in small increments.*

### ⚠ CAUTION

**Moving sanding belts are dangerously abrasive. Use extreme caution when working near sanding surfaces. Use extreme caution while making adjustments that require momentary or extended operation of the edge sander. Failure to exercise care while sanding could result in severe personal injury.**

4. When the tracking is correct, allow the sander to run for approximately one minute to verify that the tracking stays in the correct position.
5. Repeat **Steps 3 & 4** if the tracking does not stay correct; otherwise, proceed to **Step 6**.
6. When the sanding belt is tracking correctly, tighten the belt tension lock knob.



# SECTION 5: ACCESSORIES

## **!WARNING**

Installing unapproved accessories may cause machine to malfunction, resulting in serious personal injury or machine damage. To reduce this risk, only install accessories recommended for this machine by Grizzly.

## **NOTICE**

Refer to our website or latest catalog for additional recommended accessories.

### 6" x 80" Sanding Belts (2-Pc.)

Model & Type	Grit
D1263 Aluminum Oxide.....	60
D1264 Aluminum Oxide.....	80
D1265 Aluminum Oxide.....	100
D1266 Aluminum Oxide.....	120
D1267 Aluminum Oxide.....	150
D1268 Aluminum Oxide.....	180
D1269 Aluminum Oxide.....	220



Figure 43. Aluminum oxide sanding belts.

### Pro-Stik® Abrasive Belt Cleaners

W1306—Small: (1 1/2" x 1 1/2" x 8 1/2")

W1307—Large: (2" x 2" x 12")



Figure 44. Pro-Stik® Belt Cleaners.

### T28922—Bear Crawl "Cub" Mobile Base

The Cub version of the Bear Crawl was designed for small-footprint machines weighing up to 900lbs. It features wide-inline fixed casters and outrigger swivel casters to keep your equipment moving effortlessly on almost any surface. This is a high-quality mobile base that will make your shop more convenient and efficient and will keep your equipment stable and rolling for years to come. Adjusts from 14" x 14" to 22 1/2" x 22 1/2"!

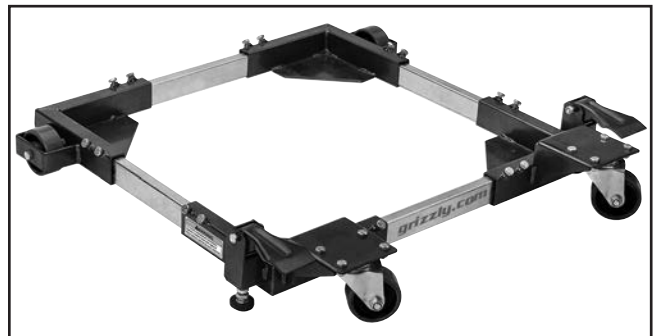


Figure 45. T28922 Bear Crawl "Cub" Mobile Base.

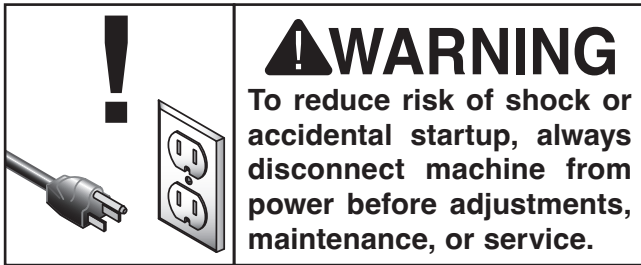
**order online at [www.grizzly.com](http://www.grizzly.com) or call 1-800-523-4777**



# SECTION 6: MAINTENANCE

---

---



## Schedule

---

---

For optimum performance from this machine, this maintenance schedule must be strictly followed.

### Ongoing

To maintain a low risk of injury and proper machine operation, if you ever observe any of the items below, shut down the machine immediately and fix the problem before continuing operations:

- Loose mounting bolts.
- Worn or damaged sanding belt.
- Worn or damaged wires.
- Any other unsafe condition.

### Weekly/Monthly Maintenance

- Wipe down work table and end table with lubricant.
- Clean/vacuum dust buildup from inside cabinet and off motor.

## Cleaning & Protecting

---

---

Cleaning the Model G1140/G1531 is relatively easy. Vacuum excess wood chips and sawdust, and wipe off the remaining dust with a dry cloth. If any resin has built up, use a resin dissolving cleaner to remove it.

Protect the unpainted cast iron table by wiping it clean after every use—this ensures moisture from wood dust does not remain on bare metal surfaces. Keep the table rust-free with regular applications of products like G96® Gun Treatment, SLIPIT®, or Boeshield® T-9.

## Sanding Belt

---

---

The sanding belt should be regularly cleaned as it becomes clogged with sawdust. Clean the sanding belt with PRO STIK® belt cleaners (Model G1511/G1512, as shown on **Page 29**). Belts that are regularly cleaned have a much longer useful life, than belts that are neglected.



# Lubrication

---

## Bearings

Since all bearings are shielded and permanently lubricated, simply leave them alone until they need to be replaced. DO NOT lubricate them.

## Table Height Leadscrew

Wipe off built-up sawdust and brush a light coat of NLGI #2 grease onto the leadscrew threads (Figure 46). After lubricating, be sure to move the leadscrew through the full range of motion that it can travel, so that the grease is spread evenly.

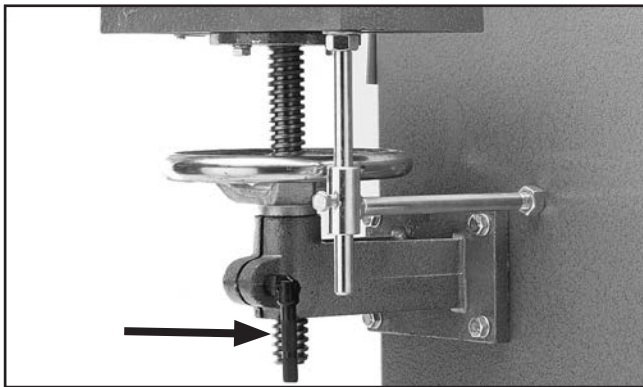


Figure 46. Locations to lubricate leadscrew.

## Tension Shaft

Apply a few drops of light machine oil, such as Model H3788 G96® Gun Treatment (see Page 29) at the locations indicated in Figure 47. Move the tension lever back-and-forth a few times to spread the oil evenly.

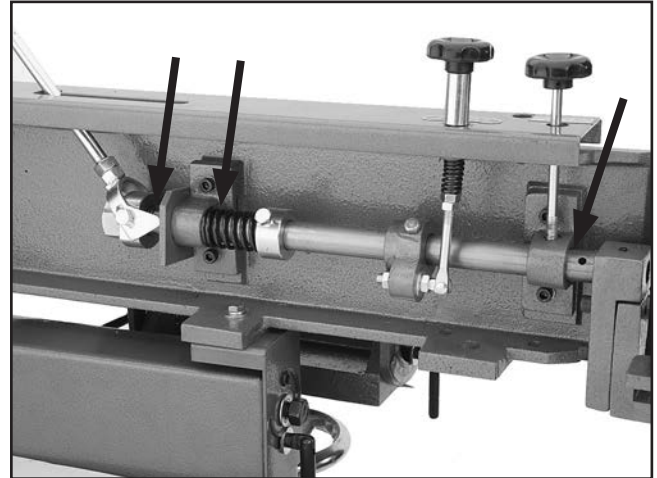


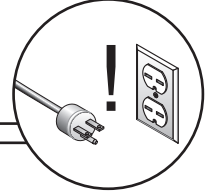
Figure 47. Tension shaft lubrication locations.



# SECTION 7: SERVICE

Review the troubleshooting procedures in this section if a problem develops with your machine. If you need replacement parts or additional help with a procedure, call our Technical Support. **Note:** *Please gather the serial number and manufacture date of your machine before calling.*

## Troubleshooting



### Motor & Electrical

Symptom	Possible Cause	Possible Solution
Machine does not start or a breaker trips.	<ol style="list-style-type: none"> <li>1. Switch disabling key is removed.</li> <li>2. Power supply switched OFF or is at fault.</li> <li>3. Start capacitor is at fault.</li> <li>4. Motor connection wired incorrectly.</li> <li>5. Wall fuse/circuit breaker is blown/tripped.</li> <li>6. Wiring is open/has high resistance.</li> <li>7. Motor ON button or ON/OFF switch is at fault.</li> </ol>	<ol style="list-style-type: none"> <li>1. Install switch disabling key.</li> <li>2. Ensure power supply is switched on; ensure power supply has the correct voltage.</li> <li>3. Test/replace if faulty.</li> <li>4. Correct motor wiring connections.</li> <li>5. Ensure circuit size is suitable for this machine; replace weak breaker.</li> <li>6. Check for broken wires or disconnected/corroded connections, and repair/replace as necessary.</li> <li>7. Replace faulty ON button or ON/OFF switch.</li> </ol>
Machine stalls or is overloaded.	<ol style="list-style-type: none"> <li>1. Workpiece material is not suitable for this machine.</li> <li>2. Motor connection is wired incorrectly.</li> <li>3. Motor bearings are at fault.</li> <li>4. Machine is undersized for the task.</li> <li>5. Motor has overheated.</li> <li>6. Motor is at fault.</li> </ol>	<ol style="list-style-type: none"> <li>1. Only cut wood products; make sure moisture content is below 20% and there are no foreign materials in the workpiece.</li> <li>2. Correct motor wiring connections.</li> <li>3. Test by rotating shaft; rotational grinding/loose shaft requires bearing replacement.</li> <li>4. Use new sandpaper with appropriate grit; reduce the feed rate/depth of sanding.</li> <li>5. Clean off motor, let cool, and reduce workload.</li> <li>6. Test/repair/replace.</li> </ol>
Machine has vibration or noisy operation.	<ol style="list-style-type: none"> <li>1. Motor or component is loose.</li> <li>2. Motor mount loose/broken/incorrect.</li> <li>3. Machine sits unevenly.</li> <li>4. Motor fan is rubbing on fan cover.</li> <li>5. Motor bearings are at fault.</li> </ol>	<ol style="list-style-type: none"> <li>1. Inspect/replace stripped or damaged bolts/nuts, and re-tighten with thread locking fluid.</li> <li>2. Tighten/replace/adjust.</li> <li>3. Relocate/shim machine.</li> <li>4. Replace dented fan cover; replace loose/damaged fan.</li> <li>5. Test by rotating shaft; rotational grinding/loose shaft requires bearing replacement.</li> </ol>



# Edge Sander Operations



Symptom	Possible Cause	Possible Solution
Machine vibrates excessively (non-motor related).	<ol style="list-style-type: none"> <li>1. Stand not stable on floor.</li> <li>2. Incorrect sanding belt tension.</li> <li>3. Weak or broken tension spring.</li> <li>4. Idler roller is too loose.</li> <li>5. Broken/defective sanding belt.</li> </ol>	<ol style="list-style-type: none"> <li>1. Reposition to level surface, or shim stand.</li> <li>2. Make sure tension lever is engaged (see <b>Page 34</b>).</li> <li>3. Replace spring.</li> <li>4. Adjust idler roller.</li> <li>5. Replace sanding belt.</li> </ol>
Sanded surface not square.	<ol style="list-style-type: none"> <li>1. Table not perpendicular to belt.</li> </ol>	<ol style="list-style-type: none"> <li>1. Adjust table tilt (see <b>Page 22</b>).</li> </ol>
Deep sanding grooves or scores in workpiece.	<ol style="list-style-type: none"> <li>1. Sandpaper too coarse for the desired finish.</li> <li>2. Workpiece sanded across the grain.</li> <li>3. Too much sanding force on workpiece.</li> <li>4. Workpiece held still against the belt.</li> </ol>	<ol style="list-style-type: none"> <li>1. Use a finer grit sanding belt.</li> <li>2. Sand with the grain.</li> <li>3. Reduce pressure on workpiece while sanding.</li> <li>4. Keep workpiece moving while sanding on the belt.</li> </ol>
Abrasive grit rubs off the belt easily.	<ol style="list-style-type: none"> <li>1. Sanding belt has been stored in an incorrect environment.</li> <li>2. Sanding belt has been folded or smashed.</li> </ol>	<ol style="list-style-type: none"> <li>1. Store sanding belt away from extremely dry/hot or damp/wet temperatures.</li> <li>2. Store sanding belt flat, not folded or bent.</li> </ol>
Sanding belt surfaces clog quickly or burn.	<ol style="list-style-type: none"> <li>1. Too much pressure against belt.</li> <li>2. Sanding softwood.</li> <li>3. Sanding belt too fine.</li> </ol>	<ol style="list-style-type: none"> <li>1. Reduce pressure on workpiece while sanding.</li> <li>2. Use different stock. Or, accept the characteristics of the stock and plan on cleaning/replacing belts frequently.</li> <li>3. Use coarser grit sanding belt.</li> </ol>
Burn marks on workpiece.	<ol style="list-style-type: none"> <li>1. Using too fine of sanding grit.</li> <li>2. Using too much pressure.</li> <li>3. Work held still for too long.</li> </ol>	<ol style="list-style-type: none"> <li>1. Use a coarser grit sanding belt.</li> <li>2. Reduce pressure on workpiece while sanding.</li> <li>3. Do not keep workpiece in one place for too long.</li> </ol>
Glazed sanding surfaces.	<ol style="list-style-type: none"> <li>1. Sanding wet stock.</li> <li>2. Sanding stock with high residue.</li> </ol>	<ol style="list-style-type: none"> <li>1. Dry stock properly before sanding.</li> <li>2. Use different stock. Or, accept the characteristics of the stock and plan on cleaning/replacing belts frequently.</li> </ol>
Workpiece frequently gets pulled out of your hand.	<ol style="list-style-type: none"> <li>1. Not supporting the workpiece against the stop (G1140).</li> <li>2. Starting the workpiece on a leading corner.</li> </ol>	<ol style="list-style-type: none"> <li>1. Use back stop to support workpiece (Model G1140).</li> <li>2. Start workpiece on a trailing corner.</li> </ol>
Hard to install belts, belt slaps against platen, slips on rollers.	Tension adjusted incorrectly.	Adjust tensioner (see <b>Page 34</b> ).
Weak tension spring, excessive play in belt tension lever.	Spring tension incorrect.	Reset spring tension (see <b>Page 35</b> ).
Belt has difficulty tracking correctly.	Parallel tracking incorrect.	Adjust parallel tracking (see <b>Page 36</b> ).
Belt tension lever stiff.	<ol style="list-style-type: none"> <li>1. Shaft spring tension incorrect.</li> <li>2. Tension shaft needs lubrication.</li> <li>3. Idler roller-to-platen relationship incorrect.</li> </ol>	<ol style="list-style-type: none"> <li>1. Adjust shaft spring tension (see <b>Page 35</b>).</li> <li>2. Lubricate tension shaft (see <b>Page 31</b>).</li> <li>3. Adjust idler roller-to-platen relationship (see <b>Page 39</b>).</li> </ol>



# Adjusting Tensioner

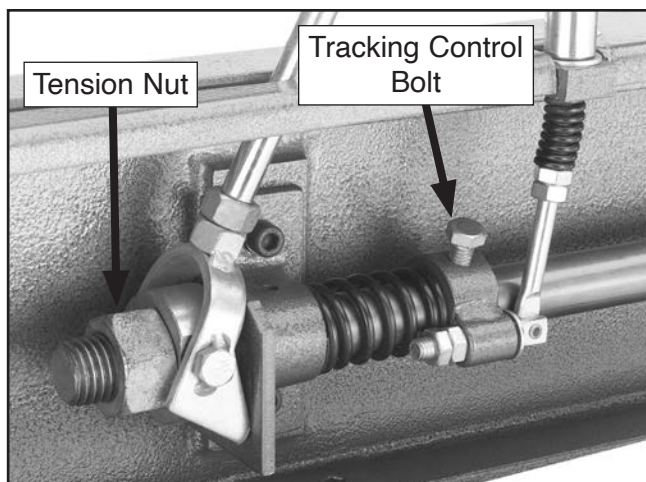
The belt tensioner is normally adjusted as the belt stretches. Two good indications of belt stretch (or a loose belt) are if the belt slaps against the platen while running or if it slips on the rollers.

On the other hand, if the belt tension is too tight, you will have a hard time installing and removing the belt when the belt tension is released.

<b>Tools Needed</b>	<b>Qty</b>
Adjustable Wrench, 1½" Jaw Capacity .....	1

## To adjust the belt tensioner:

1. DISCONNECT SANDER FROM POWER!
2. Lower the work table as far as it will go.
3. Loosen the belt tension lock knob, release the belt tension, and remove the idler roller guard and back stop (Model G1140).
4. Open the dust hood, then remove the sanding belt from the sander.
5. Move the belt tension lever to the position where the belt is normally tensioned.
6. Rotate the tension nut (**Figure 48**) counterclockwise to increase the belt tension and clockwise to decrease the belt tension.



**Figure 48.** Belt tension nut and tracking control bolt.

— *Decreased Belt Tension:* If you rotated the tension nut clockwise, move the belt tension lever to the release position. If it is not too stiff, continue to **Step 7**. If it is too stiff to move comfortably, then either the shaft spring tension needs to be reset, the tension shaft needs lubrication (refer to **Page 31**), or the idler roller-to-platen relationship needs to be adjusted (refer to **Platen-Roller Adjustment on Page 39**).

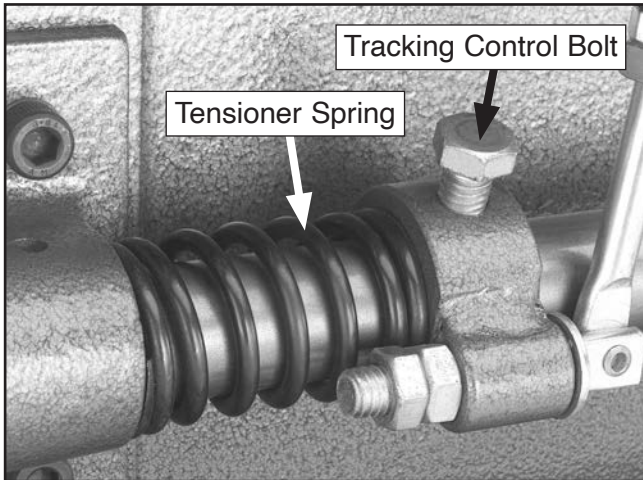
— *Increased Belt Tension:* If you rotated the tension nut counterclockwise, check the beginning movement of the belt tension lever. If there is no play in the first 2" of travel, continue to **Step 7**. If there is play in the first 2", then the tension shaft spring tension needs to be reset, as described in **Resetting Tensioner Spring Tension on Page 35**.

7. Replace the sanding belt and other components removed in **Steps 3 & 4** and examine the effect of the tension adjustment on your belt. Repeat the adjustment procedure if necessary.



# Resetting Tensioner Spring Tension

The tensioner spring (shown in **Figure 49**) applies pressure to the sanding belt when the belt tension lever is in the tension position. When repeated adjustments are made to the tensioner nut, the spring tension may lose the original setting from the factory, at which point it will need to be reset.



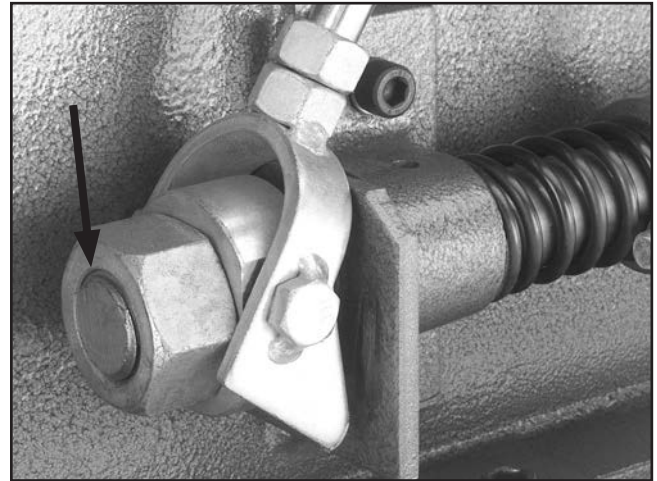
**Figure 49.** Tensioner spring and tracking control bolt.

Tools Needed	Qty
Wrench 14mm .....	1
Assistant .....	1

## To reset the tensioner spring:

1. DISCONNECT SANDER FROM POWER!
2. Loosen the tension lock knob and remove the idler roller guard and the sanding belt.
3. Move the tension lever to the tension position.

4. Turn the tension nut until the threads of the tension shaft are flush with the nut, as shown in **Figure 50**.



**Figure 50.** Tension nut flush with threads.

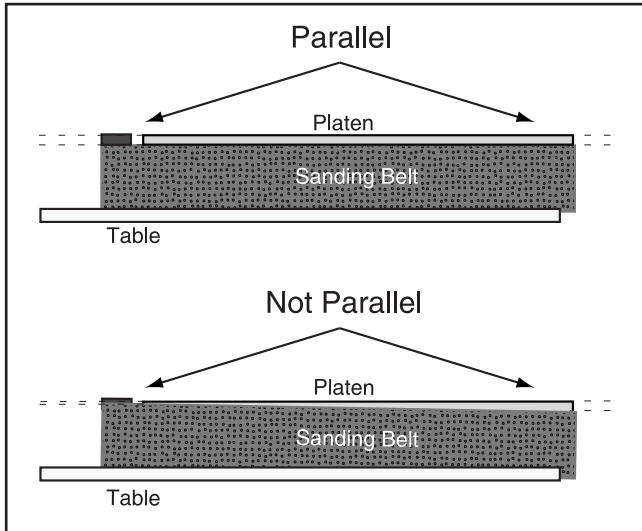
5. Loosen the tracking control bolt.
6. While an assistant pulls on the idler roller to take up the slack in the tension shaft, tighten the tracking control bolt.
7. Turn the tension nut clockwise approximately three full turns.
8. Engage and disengage the belt tension lever, then tighten the tension nut two more full turns.
9. Adjust the idler roller-to-platen relationship, as described on **Page 39**.
10. Re-install the sanding belt and idler roller guard, then track the sanding belt before operating the sander.

**Note:** *It may be necessary to slightly adjust the tension nut to make the table fit.*



# Parallel Belt Tracking

The belt should track on the rollers so that the top edge of the sanding belt stays parallel with the top edge of the platen graphite, as illustrated in **Figure 51**.



**Figure 51.** Illustration of parallel belt tracking.

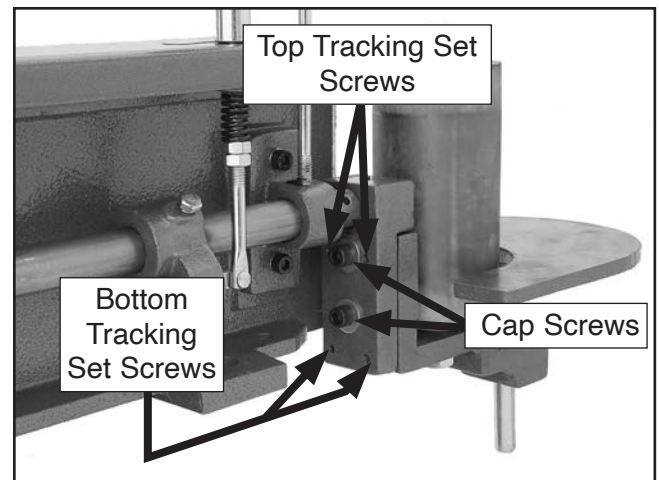
Tools Needed	Qty
Ruler .....	1
Hex Wrench 3mm.....	1
Hex Wrench 8mm.....	1

## To check the parallel tracking of the sanding belt:

- Track the belt so it is centered on the main roller and the top of the belt is parallel with the top of the platen, as shown in **Figure 51**.
  - If the top of the belt is not parallel with the top of the platen, and the **low side of the belt is more than 1/8" away from the top of the platen**, write down the distance between the low side of the belt and the top of the platen, then proceed with parallel belt tracking instructions.
  - If the top of the belt is not parallel with the top of the platen and the **low side of the belt is less than 1/8" away from the top of the platen**, then you do not need to adjust your belt for parallel tracking.

## To adjust the parallel tracking of the sanding belt:

- DISCONNECT SANDER FROM POWER!
- Remove the dust port.
- Remove the sanding belt.
- Loosen the two cap screws behind the idler roller, shown in **Figure 52**, approximately half a turn, and notice the four set screws nearby—these control the parallel tracking of the sanding belt.



**Figure 52.** Idler roller adjustment screws.

- Thread in the appropriate pair of parallel tracking set screws approximately 1/4–1/2 a turn, as discussed below.
  - If the **low side of the belt is on the left end** of the sander (facing front of sander), then thread the two bottom set screws into the plate (clockwise) and unthread (counterclockwise) the two top set screws out of the plate in the same amount of turns as the bottom set screws.
  - If the **low side of the of the belt is on the right end** of the sander (facing front of sander), then evenly thread the two top set screws into the plate (clockwise) and evenly unthread (counterclockwise) the two bottom set screws out of the plate in the same amount of turns as the top set screws.

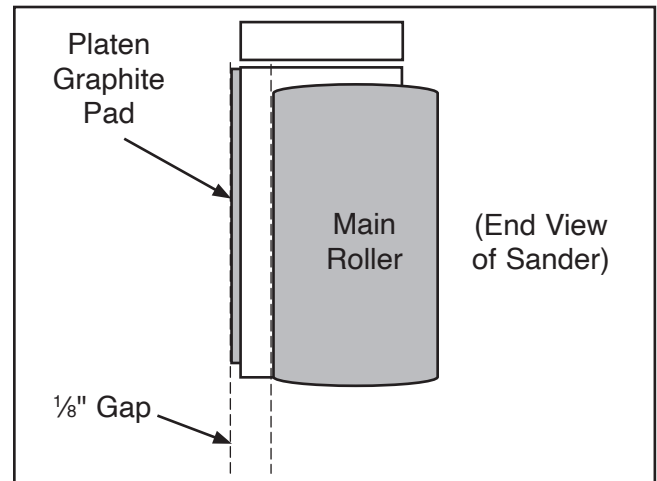


6. Tighten the two cap screws shown in **Figure 52**.
7. Replace and track the belt. The top of the belt should now be parallel with the top of the platen.
  - If the top of the belt is not parallel with the top of the platen and the low side of the belt is less than  $\frac{1}{8}$ " away from the top of the graphite, then you do not need to make further adjustments for parallel tracking.
  - If the top of the belt is not parallel with the top of the platen and the lower side of the belt is still more than  $\frac{1}{8}$ " away from the top of the graphite, estimate how much the belt moved from when you originally checked it. Compare this movement with how much you turned the two set screws in **Step 5**, then repeat **Steps 3-6**, but adjust the set screws from **Step 5** the amount that you estimate will fix the parallel tracking. Repeat as necessary until the parallel tracking is correct.

## Platen-Roller Adjustments

---

The platen can be adjusted forward or backward in relation to the main and idler rollers. When the platen graphite pad is correctly adjusted, it should extend beyond the rollers approximately  $\frac{1}{8}$ ", as shown in **Figure 53**.



**Figure 53.** Correct platen-main roller distance.

If the platen extends beyond this, the belt will stretch and the graphite pad will wear quicker.

Because the idler roller is attached to the platen, it will need to be adjusted independently to complete this procedure.

Also, if the main roller is not vertically parallel with the platen, the motor will need to be adjusted on the motor mount to complete this procedure.

Instructions for all three adjustments are given below. First, check the platen-to-roller relationship to see if you need to make the adjustments.

<b>Tools Needed</b>	<b>Qty</b>
Straightedge .....	1
Wrench 8mm .....	1
Wrench 12mm .....	1
Wrench 14mm .....	1



**To check the platen-to-main roller relationship:**

1. DISCONNECT SANDER FROM POWER!
2. Remove the dust port and sanding belt.
3. Place a straightedge across the TOP part of the platen graphite and the main roller as shown in **Figure 54**. Measure the gap, if there is one, between the straightedge and the main roller.



**Figure 54.** Example of checking top of platen-to-roller.

4. Now place the straightedge across the BOTTOM part of the platen graphite and the main roller, as shown in **Figure 55**. Measure the gap, if there is one, between the straightedge and the main roller.



**Figure 55.** Example of checking bottom of platen-to-roller.

5. Analyze the results of your check in **Steps 3-4**, using the criteria below:

— *Correct Platen-to-Main Roller Relationship:* The distance between the straightedge and the main roller is approximately  $\frac{1}{8}$ " at both the top and bottom. You do not need to adjust the platen position or the main roller position.

— *Platen is Incorrect:* The distances between the straightedge and the main roller at both the top and bottom are more or less than  $\frac{1}{8}$ ", and the distances are about the same. Action: Adjust the platen (refer to instructions on **Page 40**).

— *Main Roller is Incorrect:* The distance between the straightedge and the main roller is different at the top than it is at the bottom. Action: Adjust the main roller (refer to instructions on **Page 39**).

**To check the platen-to-idler roller relationship:**

1. Follow **Steps 1–2** from the previous instructions.
2. Place the straightedge across the TOP of the platen graphite and the idler roller in a similar manner to the method shown in **Figure 54**. Measure the gap, if there is one, between the straightedge and the idler roller.
3. Place the straightedge across the BOTTOM of the platen graphite and the idler roller. Measure the gap, if there is one, between the straightedge and the idler roller.

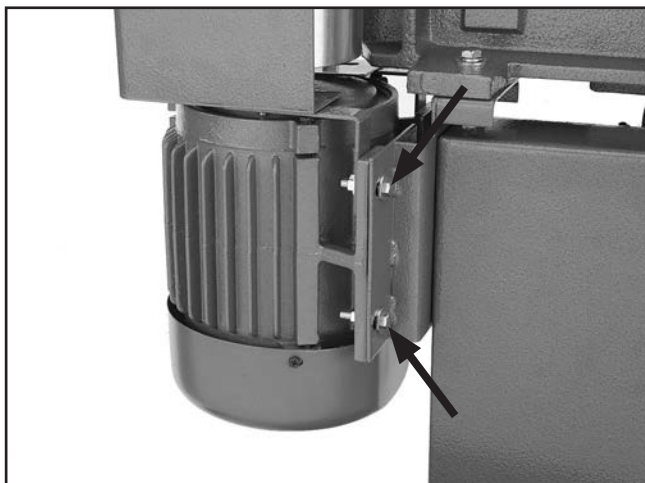
— *Correct Platen-to-Idler Roller Relationship:* The distance between the straightedge and the idler roller is approximately  $\frac{1}{8}$ " at both the top and bottom. You do not need to adjust the idler roller position.

— *Idler Roller Incorrect:* The distances between the straightedge and the idler roller at both the top and bottom are more or less than  $\frac{1}{8}$ ". Action: Adjust the idler roller (refer to instructions on **Page 39**).



**To adjust the main roller-to-platen relationship:**

1. DISCONNECT SANDER FROM POWER!
2. Remove the sanding belt and dust port.
3. Loosen the four motor mount bolts/nuts that secure the motor to the motor bracket. **Figure 56** shows two of the four motor mount bolts.

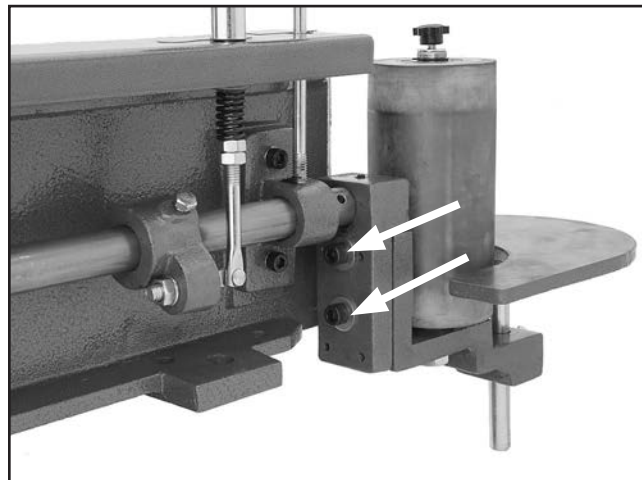


**Figure 56.** Two of the four motor mount bolts.

4. Place a straightedge across the TOP part of the platen graphite and the main roller, and adjust the main roller so that it is to  $\frac{1}{8}$ " behind the platen graphite at both the top and bottom of the roller.
5. Tighten the motor mount bolts carefully, making sure not to move the motor from its corrected position.
6. Recheck the main roller-to-platen alignment. Follow **Steps 1-5** *To check the platen to main roller relationship* on **Page 38**.
  - If the alignment is correct, then it is adjusted correctly. Proceed to **Step 7**.
  - If the alignment is incorrect, repeat **Steps 3-5**.
7. Replace the sanding belt and dust port, and retrack the sanding belt (refer to **Page 28**) before resuming sanding operations.

**To adjust the idler roller-to-platen relationship:**

1. DISCONNECT SANDER FROM POWER!
2. Remove the sanding belt.
3. Loosen the two cap screws, shown in **Figure 57**, approximately one full turn.



**Figure 57.** Idler roller adjustment cap screws.

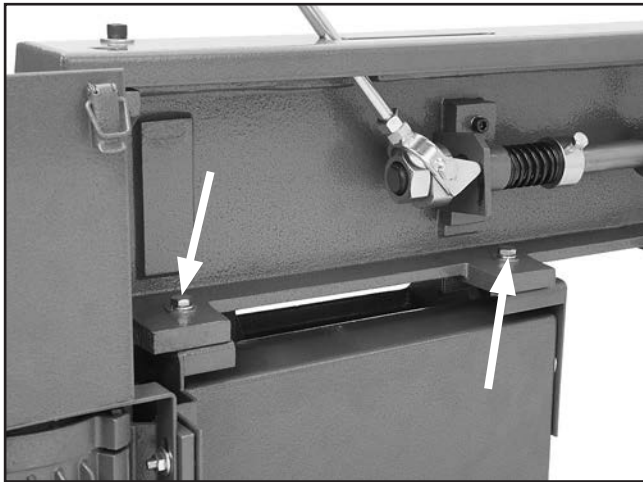
4. Place a straightedge across the TOP part of the platen graphite and in front of the idler roller, and adjust the idler roller so that it is approximately  $\frac{1}{8}$ " away from the straight-edge.
5. Place a straightedge across the BOTTOM part of the platen graphite and in front of the idler roller, and adjust the idler roller so that it is approximately  $\frac{1}{8}$ " away from the straight-edge.
6. Check the adjustments made in **Steps 4-5**, and tighten the cap screws that you loosened in **Step 3**, making sure not to move the corrected idler roller position during tightening.
7. Replace the sanding belt and dust port, and retrack the sanding belt (refer to **Page 28**) before resuming sanding operations.



The platen can also be adjusted, but this adjustment should be done carefully because moving the platen too far will make the sanding belt press against the table.

**To adjust the platen:**

1. DISCONNECT MACHINE FROM POWER!
2. Remove the sanding belt and dust port.
3. Loosen the two hex bolts shown in Figure 59.



**Figure 58.** Hex bolts that secure platen for adjustments.

4. Place a straightedge across the platen graphite and in front of the main roller.
5. Adjust the platen so the distance between the straightedge and main roller is approximately  $\frac{1}{8}$ ".
6. Tighten both hex bolts in an even manner and recheck the distance between the platen and the main roller to make sure that it did not move when you tightened the hex bolts.
  - If the platen did move, repeat **Steps 3-5** until it is positioned properly.
  - If the platen did not move, then it is adjusted correctly. Proceed to **Step 7**.
7. Replace the sanding belt and dust port, and retrack the sanding belt (refer to **Page 28**) before resuming sanding operations.



# G1140 Wiring Diagram

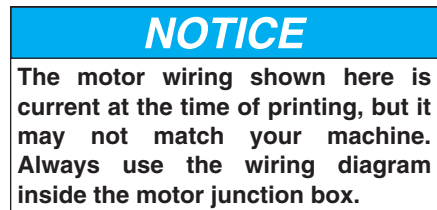
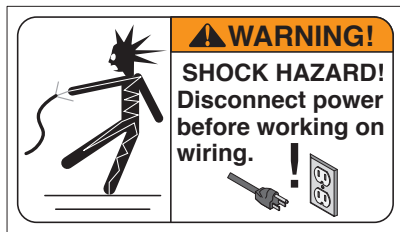
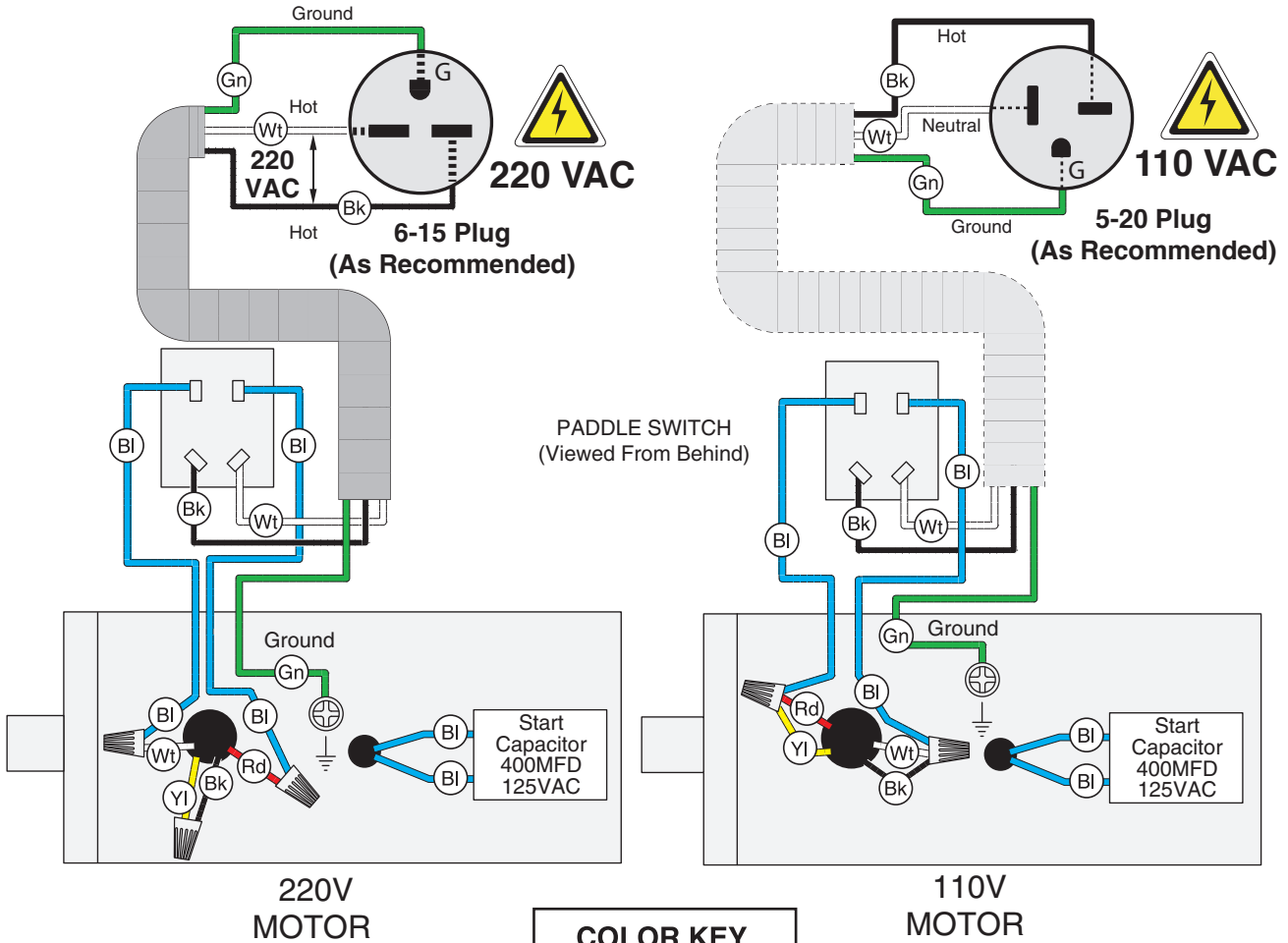


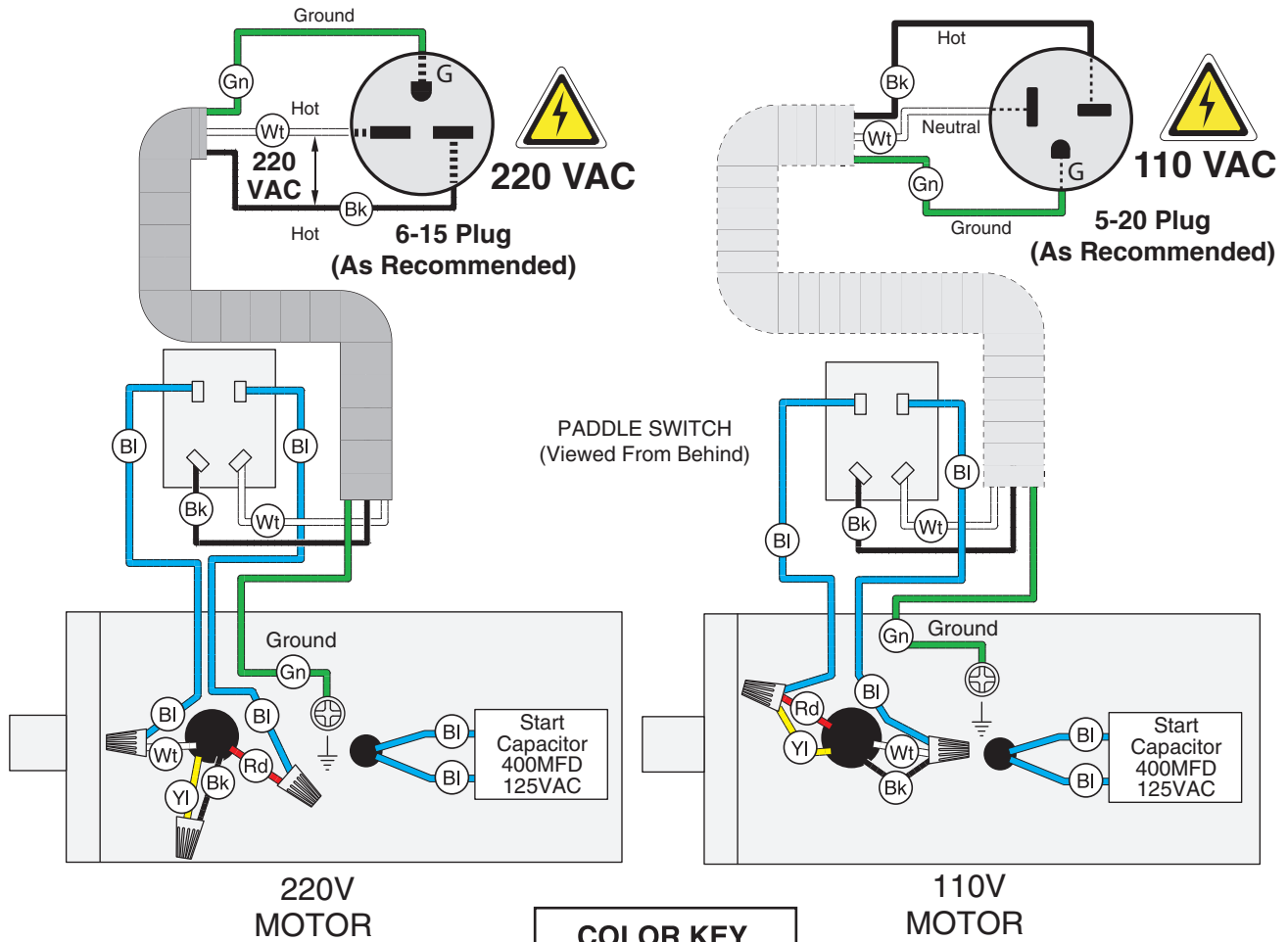
Figure 59. G1140 motor wiring (prewired 220V).



Figure 60. G1140 capacitor.



# G1531 Wiring Diagram



**⚠ WARNING!**

**SHOCK HAZARD!**  
Disconnect power before working on wiring.

**NOTICE**

The motor wiring shown here is current at the time of printing, but it may not match your machine. Always use the wiring diagram inside the motor junction box.



Figure 61. G1531 motor wiring (prewired 220V).



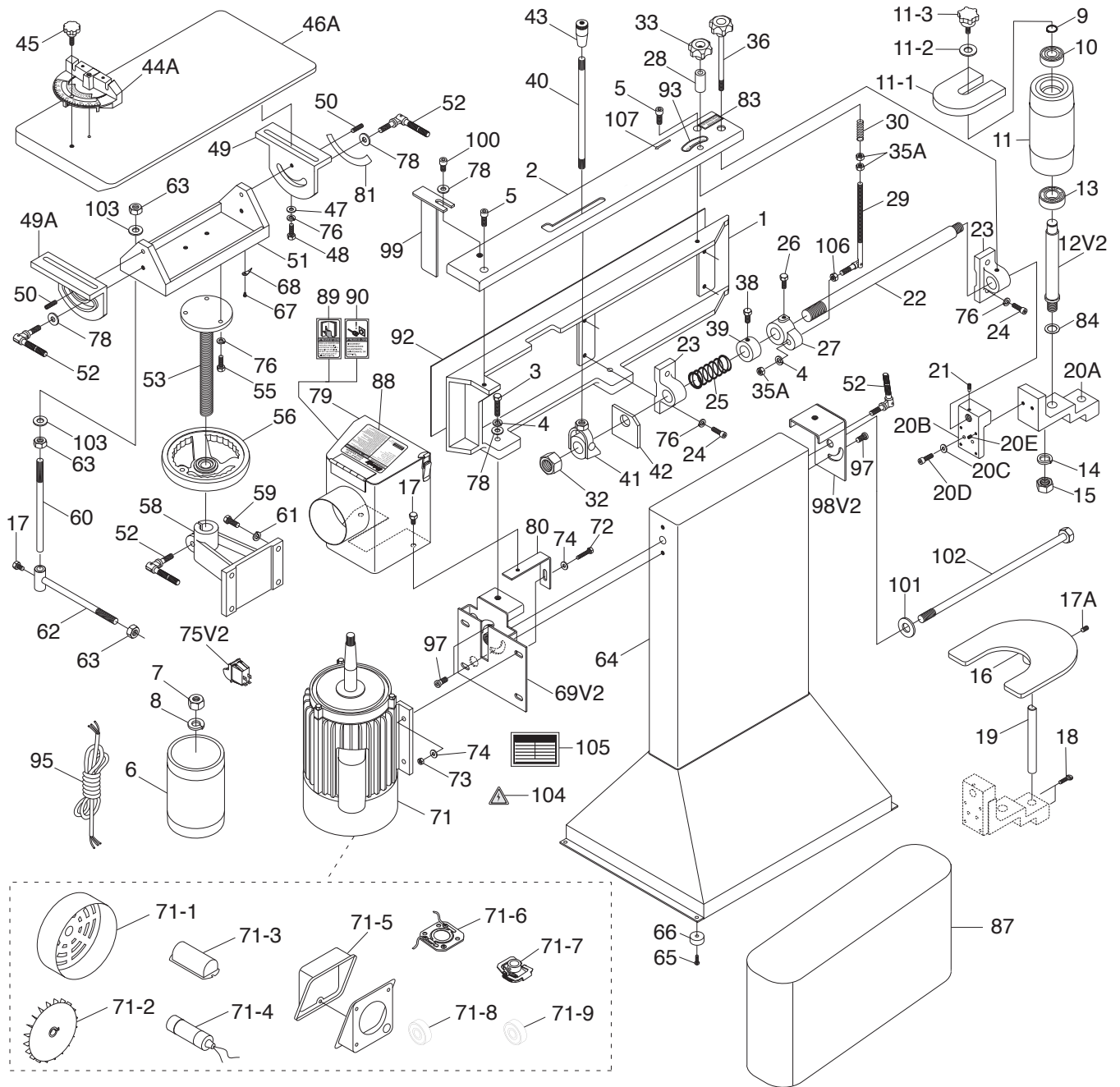
Figure 62. G1531 capacitor.



# SECTION 8: PARTS

We do our best to stock replacement parts when possible, but we cannot guarantee that all parts shown are available for purchase. Call (800) 523-4777 or visit [www.grizzly.com/parts](http://www.grizzly.com/parts) to check for availability.

## G1140 Parts Breakdown



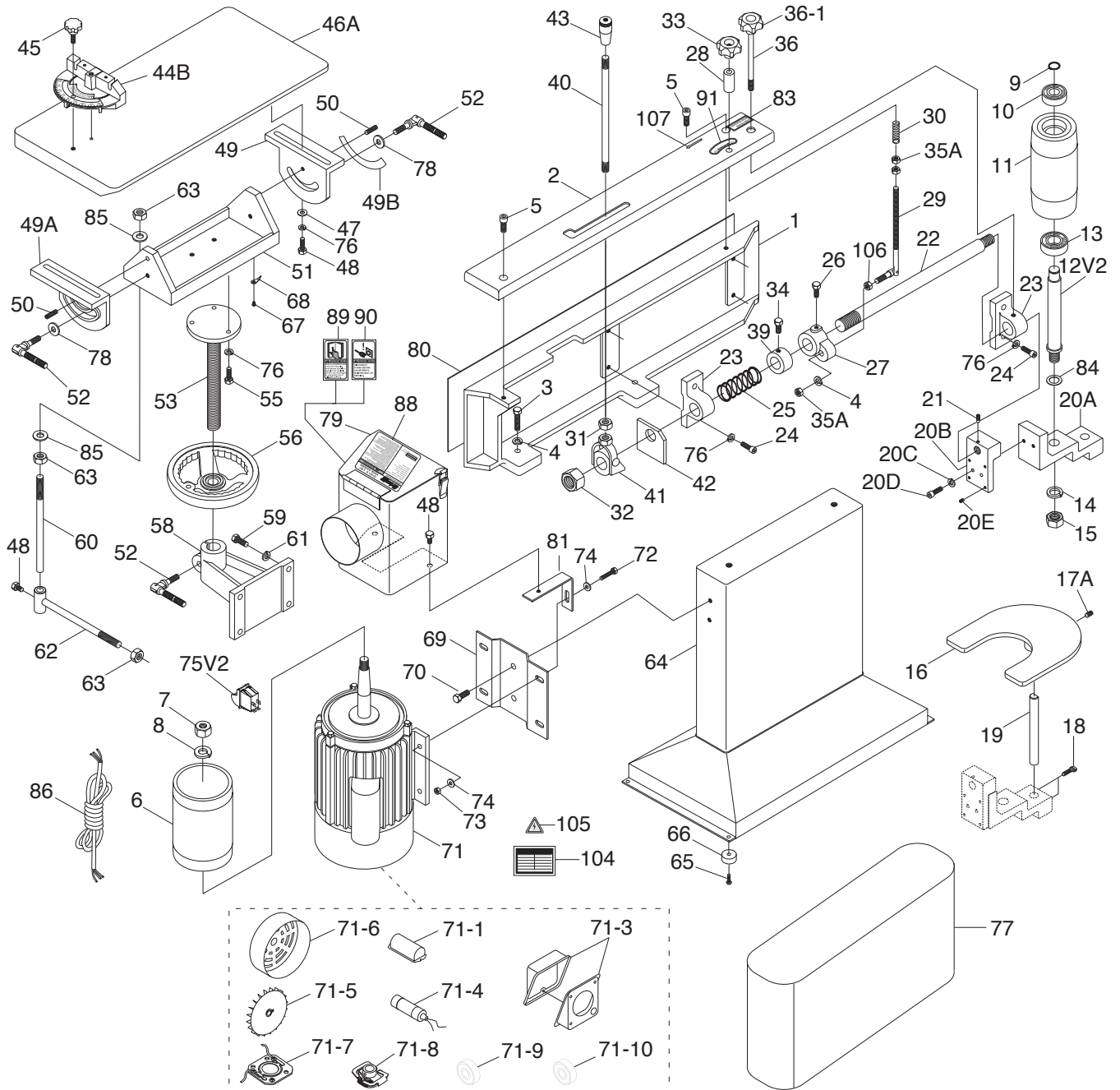
# G1140 Parts List

REF	PART #	DESCRIPTION
1	P1140001	PLATEN
2	P1140002	PLATEN COVER
3	P1140003	HEX BOLT 3/8-16 X 1-1/2
4	P1140004	LOCK WASHER 3/8
5	P1140005	CAP SCREW 3/8-16 X 1
6	P1140006	DRIVE ROLLER
7	P1140007	HEX NUT 5/8-18
8	P1140008	LOCK WASHER 5/8
9	P1140009	EXT RETAINING RING 3/4
10	P1140010	BALL BEARING 6204ZZ
11	P1140011	RUBBER IDLER ROLLER
11-1	P1140011-1	IDLER ROLLER GUARD
11-2	P1140011-2	FLAT WASHER 1/4
11-3	P1140011-3	SMALL STAR KNOB
12V2	P1140012V2	ROLLER AXLE V2.04.03
13	P1140013	BALL BEARING 6205ZZ
14	P1140014	LOCK WASHER 5/8
15	P1140015	HEX NUT 5/8-11
16	P1140016	AUXILLARY TABLE
17	P1140017	HEX BOLT 5/16-18 X 1/2
17A	P1140017A	SET SCREW 5/16-18 X 5/8
18	P1140018	THUMBSCREW 1/4-20 x 2
19	P1140019	AUXILIARY TABLE POST
20A	P1140020A	ROLLER SUPPORT BRACKET
20B	P1140020B	ROLLER BLOCK BRACKET
20C	P1140020C	FLAT WASHER 3/8
20D	P1140020D	CAP SCREW 3/8-16 X 1-1/2
20E	P1140020E	SET SCREW 1/4-20 X 5/8
21	P1140021	SPECIAL SCREW
22	P1140022	BELT ADJUST SHAFT
23	P1140023	ADJUST SHAFT SLIDE
24	P1140024	CAP SCREW 5/16-18 X 1
25	P1140025	COMPRESSION SPRING 36 X 78
26	P1140026	HEX BOLT 5/16-18 X 3/4
27	P1140027	ARM CONTROL CASTING
28	P1140028	SLEEVE
29	P1140029	CONTROL SHAFT
30	P1140030	SPRING
32	P1140032	HEX NUT 1-8
33	P1140033	TILT KNOB
35A	P1140035A	HEX NUT 3/8-16
36	P1140036	LOCK KNOB 3/8"
38	P1140038	HEX BOLT 5/16-18 X 3/8
39	P1140039	COLLAR
40	P1140040	LEVER
41	P1140041	SWIVEL ASSEMBLY
42	P1140042	PLATE
43	P1140043	KNOB
44A	P1140044A	MITER GAUGE BODY
45	P1140045	KNOB 5/16" X 1"
46A	P1140046A	TABLE V2.07.98
47	P1140047	FLAT WASHER 5/16
48	P1140048	HEX BOLT 5/16-18 X 1
49	P1140049	TILT SLIDES LEFT
49A	P1140049A	TILT SLIDES RIGHT
50	P1140050	SET SCREW 5/16-18 X 1

REF	PART #	DESCRIPTION
51	P1140051	TABLE SUPPORT BRACKET
52	P1140052	SWIVEL LOCK HANDLE 3/8"-16 X 1-1/4"
53	P1140053	TABLE ELEVATION LEADSCREW
55	P1140055	HEX BOLT 5/16-18 X 3/4
56	P1140056	HAND WHEEL
58	P1140058	SPLIT CASTING
59	P1140059	HEX BOLT 3/8-16 X 1
60	P1140060	TABLE ADJ SHAFT
61	P1140061	LOCK WASHER 3/8
62	P1140062	LEVELING ARM SHAFT
63	P1140063	HEX NUT 1/2"-13
64	P1140064	STAND
65	P1140065	PHLP HD SCR 10-24 X 3/4
66	P1140066	FEET
67	P1140067	PHLP HD SCR 8-32 x 1/4
68	P1140068	POINTER
69V2	P1140069V2	MOTOR BRACKET V2.08.14
71	P1140071	MOTOR 1-1/2HP 110/220V 1PH
71-1	P1140071-1	FAN COVER
71-2	P1140071-2	MOTOR FAN
71-3	P1140071-3	CAPACITOR COVER
71-4	P1140071-4	S CAPACITOR 400M 125V 1-7/8 X 3-3/8
71-5	P1140071-5	JUNCTION BOX
71-6	P1140071-6	CONTACT PLT-TUNGSTEN 5HP OR LESS
71-7	P1140071-7	CENT SWITCH 5/8-1725
71-8	P1140071-8	BALL BEARING 6203ZZ
71-9	P1140071-9	BALL BEARING 6205ZZ
72	P1140072	HEX BOLT 5/16-18 X 1-1/4
73	P1140073	HEX NUT 5/16"-18
74	P1140074	FLAT WASHER 5/16
75V2	P1140075V2	GRIZZLY SAFETY PADDLE SWITCH
76	P1140076	LOCK WASHER 5/16
78	P1140078	FLAT WASHER 3/8
79	P1140079	DUST COLLECTION HOOD
80	P1140080	SUPPORT BRACKET DUST HOOD
81	P1140081	ANGLE SCALE
83	P1140083	BELT TENSION LOCK KNOB LABEL
84	P1140084	SPECIAL WASHER 5/8 X 30 X 27
87	P1140087	BELT 6" X 80" P100
88	P1140088	G1140 ID LABEL
89	P1140089	READ MANUAL-VERTICAL NS 7/05
90	P1140090	DISCONNECT 220V 2W X 3.3H
92	P1140092	GRAPHITE PAD 6"W X 29"L
93	P1140093	BELT TRACKING CONTROL LABEL
95	P1140095	POWER CORD 16AWG 3-WIRE 68"L
97	P1140097	SPECIAL SCREW 3/8-16
98V2	P1140098V2	BRACKET V2.08.14
99	P1140099	BACK STOP
100	P1140100	CAP SCREW 3/8-16 X 1
101	P1140101	SPECIAL WASHER 5/8 X 30 X 27
102	P1140102	LOCK BOLT 5/8-11
103	P1140103	FLAT WASHER 1/2
104	P1140104	ELECTRICITY LABEL
105	P1140105	G1140 MOTOR LABEL
106	P1140106	HEX NUT 3/8-16
107	P1140107	BELT ROTATION LABEL



# G1531 Parts Breakdown



## ⚠ WARNING

Safety labels help reduce the risk of serious injury caused by machine hazards. If any label comes off or becomes unreadable, the owner of this machine **MUST** replace it in the original location before resuming operations. For replacements, contact (800) 523-4777 or [www.grizzly.com](http://www.grizzly.com).



# G1531 Parts List

REF	PART #	DESCRIPTION
1	P1531001	PLATEN
2	P1531002	PLATEN COVER
3	P1531003	HEX BOLT 3/8-16 X 1-1/2
4	P1531004	LOCK WASHER 3/8"
5	P1531005	CAP SCREW 3/8"-16 X 1"
6	P1531006	DRIVE ROLLER
7	P1531007	HEX NUT 5/8"-18
8	P1531008	LOCK WASHER 5/8"
9	P1531009	EXT RETAINING RING 3/4
10	P1531010	BALL BEARING 6204ZZ
11	P1531011	RUBBER IDLER ROLLER
12V2	P1531012V2	ROLLER AXLE V2.04.03
13	P1531013	BALL BEARING 6205ZZ
14	P1531014	LOCK WASHER 5/8"
15	P1531015	HEX NUT 5/8"-11
16	P1531016	AUXILLARY TABLE
17A	P1531017A	SET SCREW 5/16-18 X 5/8
18	P1531018	THUMBSCREW 1/4-20 x 2
19	P1531019	AUXILLARY TABLE POST
20A	P1531020A	ROLLER SUPPORT BRACKET V2.12.97
20B	P1531020B	ROLLER BLOCK BRACKET V2.11.98
20C	P1531020C	FLAT WASHER 3/8
20D	P1531020D	CAP SCREW 3/8"-16 X 1-1/2"
20E	P1531020E	SET SCREW 1/4"-20 X 5/8"
21	P1531021	SPECIAL SCREW 1/4-20 X 5/8
22	P1531022	BELT ADJUST SHAFT
23	P1531023	ADJUST SHAFT SLIDE
24	P1531024	CAP SCREW 5/16"-18 X 1"
25	P1531025	COMPRESSION SPRING 36 X 78
26	P1531026	HEX BOLT 5/16-18 X 3/4
27	P1531027	ARM CONTROL CASTING
28	P1531028	SLEEVE
29	P1531029	CONTROL SHAFT
30	P1531030	SPRING 16.5 X 44
31	P1531031	HEX NUT 1/2"-13
32	P1531032	HEX NUT 1"-8 LH
33	P1531033	TILT KNOB
34	P1531034	HEX BOLT 5/16-18 X 3/8
35A	P1531035A	HEX NUT 3/8"-16
36	P1531036	KNOB W/SHAFT
36-1	P1531036-1	KNOB
39	P1531039	COLLAR
40	P1531040	LEVER
41	P1531041	SWIVEL ASSY
42	P1531042	PLATE
43	P1531043	KNOB
44B	P1531044B	MITER STOP V1.10.95
45	P1531045	KNOB 5/16-18 X 1"
46A	P1531046A	TABLE V2.07.98
47	P1531047	FLAT WASHER 5/16"
48	P1531048	HEX BOLT 5/16-18 X 1/2
49	P1531049	TILT SLIDES LEFT
49A	P1531049A	TILT SLIDES RIGHT

REF	PART #	DESCRIPTION
49B	P1531049B	ANGLE SCALE
50	P1531050	SET SCREW 5/16"-18 X 1"
51	P1531051	TABLE SUPPORT BRACKET
52	P1531052	SWIVEL LOCK HANDLE 3/8"-16 X 1-1/4"
53	P1531053	LEAD SCREW 1"-4
55	P1531055	HEX BOLT 5/16-18 X 3/4
56	P1531056	HANDWHEEL
58	P1531058	SPLIT CASTING
59	P1531059	HEX BOLT 3/8-16 X 1
60	P1531060	TABLE ADJ SHAFT
61	P1531061	LOCK WASHER 3/8
62	P1531062	LEVELING ARM SHAFT
63	P1531063	HEX NUT 1/2"-13
64	P1531064	BASE
65	P1531065	PHLP HD SCR 10-24 X 3/4
66	P1531066	FEET
67	P1531067	PHLP HD SCR 8-32 x 1/4
68	P1531068	POINTER
69	P1531069	MOTOR BRACKET
70	P1531070	HEX BOLT 3/8-16 X 1
71	P1531071	MOTOR 1-1/2HP 110/220V 1PH
71-1	P1531071-1	CAPACITOR COVER
71-3	P1531071-3	CONNECTION BOX CASE
71-4	P1531071-4	S CAPACITOR 400M 125V 1-7/8 X 3-3/8
71-5	P1531071-5	MOTOR FAN
71-6	P1531071-6	FAN COVER
71-7	P1531071-7	CONTACT PLT-TUNGSTEN 5HP OR LESS
71-8	P1531071-8	CENT SWITCH 5/8-1725
71-9	P1531071-9	BALL BEARING 6203ZZ
71-10	P1531071-10	BALL BEARING 6205ZZ
72	P1531072	HEX BOLT 5/16-18 X 1-1/4
73	P1531073	HEX NUT 5/16"-18
74	P1531074	FLAT WASHER 5/16"
75V2	P1531075V2	GRIZZLY SAFETY PADDLE SWITCH
76	P1531076	LOCK WASHER 5/16"
77	P1531077	BELT 6" X 80" P100
78	P1531078	FLAT WASHER 3/8"
79	P1531079	DUST COLLECTION HOOD
80	P1531080	GRAPHITE PAD 6"W X 29"L
81	P1531081	DUST HOOD SUPPORT BRACKET
83	P1531083	BELT TENSION LOCK KNOB LABEL
84	P1531084	SPECIAL WASHER 5/8 X 30 X 27
85	P1531085	FLAT WASHER 1/2"
86	P1531086	POWER CORD
88	P1531088	G1531 ID LABEL
89	P1531089	READ MANUAL-VERTICAL NS 7/05
90	P1531090	DISCONNECT 220V 2W X 3.3H
91	P1531091	BELT TRACKING CONTROL LABEL
104	P1531104	ELECTRICITY LABEL
105	P1531105	G1531 MOTOR LABEL
106	P1531106	HEX NUT 3/8-16
107	P1531107	BELT ROTATION LABEL







# WARRANTY & RETURNS

---

Grizzly Industrial, Inc. warrants every product it sells for a period of **1 year** to the original purchaser from the date of purchase. This warranty does not apply to defects due directly or indirectly to misuse, abuse, negligence, accidents, repairs or alterations or lack of maintenance. This is Grizzly's sole written warranty and any and all warranties that may be implied by law, including any merchantability or fitness, for any particular purpose, are hereby limited to the duration of this written warranty. We do not warrant or represent that the merchandise complies with the provisions of any law or acts unless the manufacturer so warrants. In no event shall Grizzly's liability under this warranty exceed the purchase price paid for the product and any legal actions brought against Grizzly shall be tried in the State of Washington, County of Whatcom.

We shall in no event be liable for death, injuries to persons or property or for incidental, contingent, special, or consequential damages arising from the use of our products.

The manufacturers reserve the right to change specifications at any time because they constantly strive to achieve better quality equipment. We make every effort to ensure that our products meet high quality and durability standards and we hope you never need to use this warranty.

In the event you need to use this warranty, contact us by mail or phone and give us all the details. We will then issue you a "Return Number," which must be clearly posted on the outside as well as the inside of the carton. We will not accept any item back without this number. Proof of purchase must accompany the merchandise.

Please feel free to write or call us if you have any questions about the machine or the manual.

Thank you again for your business and continued support. We hope to serve you again soon.

For further information about the warranty, visit <https://www.grizzly.com/forms/warranty> or scan the QR code below to be automatically directed to our warranty page.



***grizzly.com***<sup>®</sup>  
**TOOL WEBSITE**

Buy Direct and Save with Grizzly<sup>®</sup> – Trusted, Proven and a Great Value!  
~Since 1983~

*Visit Our Website Today For  
Current Specials!*

**ORDER  
24 HOURS A DAY!  
1-800-523-4777**

