

Grizzly **Industrial, Inc.**®

MODEL G0612 6" JOINTER OWNER'S MANUAL



COPYRIGHT © JANUARY, 2007 BY GRIZZLY INDUSTRIAL, INC. REVISED JANUARY, 2010 (JB)
**WARNING: NO PORTION OF THIS MANUAL MAY BE REPRODUCED IN ANY SHAPE
OR FORM WITHOUT THE WRITTEN APPROVAL OF GRIZZLY INDUSTRIAL, INC.
FOR MODELS MANUFACTURED SINCE JULY 2007 #JC8885 PRINTED IN CHINA**

 **WARNING!**

This manual provides critical safety instructions on the proper setup, operation, maintenance and service of this machine/equipment.

Failure to read, understand and follow the instructions given in this manual may result in serious personal injury, including amputation, electrocution or death.

The owner of this machine/equipment is solely responsible for its safe use. This responsibility includes but is not limited to proper installation in a safe environment, personnel training and usage authorization, proper inspection and maintenance, manual availability and comprehension, application of safety devices, blade/cutter integrity, and the usage of personal protective equipment.

The manufacturer will not be held liable for injury or property damage from negligence, improper training, machine modifications or misuse.

 **WARNING!**

Some dust created by power sanding, sawing, grinding, drilling, and other construction activities contains chemicals known to the State of California to cause cancer, birth defects or other reproductive harm. Some examples of these chemicals are:

- **Lead from lead-based paints.**
- **Crystalline silica from bricks, cement and other masonry products.**
- **Arsenic and chromium from chemically-treated lumber.**

Your risk from these exposures varies, depending on how often you do this type of work. To reduce your exposure to these chemicals: Work in a well ventilated area, and work with approved safety equipment, such as those dust masks that are specially designed to filter out microscopic particles.

Table of Contents

INTRODUCTION	2	SECTION 4: OPERATIONS	18
Manual Accuracy	2	Operation Safety	18
Contact Info.....	2	Basic Parts and Controls	18
Machine Description	2	Fence Angle Stops	20
Identification.....	3	Stock Inspection and Requirements.....	23
Machine Data Sheet	4	Squaring Stock.....	24
SECTION 1: SAFETY	6	Surface Planing.....	25
Safety Instructions for Machinery	6	Edge Jointing	26
Additional Safety for Jointers	8	Bevel Cutting.....	27
SECTION 2: CIRCUIT REQUIREMENTS	9	SECTION 5: ACCESSORIES	28
110V Operation.....	9	SECTION 6: MAINTENANCE	30
SECTION 3: SETUP	10	Schedule	30
Setup Safety	10	Belts	30
Unpacking	10	Cleaning.....	30
Items Needed for	10	Lubrication	30
Setup.....	10	SECTION 7: SERVICE	31
Inventory	11	Troubleshooting	31
Cleanup.....	12	Adjusting/Replacing Belts	33
Site Considerations.....	12	Replacing Motor Brushes	34
Mounting the Jointer	12	Wiring Diagram	35
Attaching the Fence Support	13	Parts Breakdown.....	36
Installing the Fence	14	Parts List.....	37
Fence Tilting Handle.....	14	Safety Label Parts List.....	38
Checking Outfeed Table Alignment.....	15	WARRANTY AND RETURNS	41
Dust Collection.....	16		
Test Run	17		

INTRODUCTION

Manual Accuracy

We are proud to offer this manual with your new machine! We've made every effort to be exact with the instructions, specifications, drawings, and photographs of the machine we used when writing this manual. However, sometimes we still make an occasional mistake.

Also, owing to our policy of continuous improvement, **your machine may not exactly match the manual**. If you find this to be the case, and the difference between the manual and machine leaves you in doubt, check our website for the latest manual update or call technical support for help.

Before calling, find the manufacture date of your machine by looking at the date stamped into the machine ID label (see below). This will help us determine if the manual version you received matches the manufacture date of your machine.

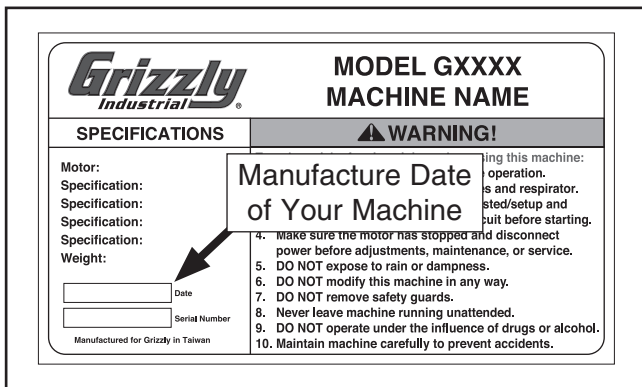

For your convenience, we post all available manuals and manual updates for free on our website at www.grizzly.com. Any updates to your model of machine will be reflected in these documents as soon as they are complete.

Contact Info

We stand behind our machines. If you have any service questions, parts requests or general questions about the machine, please call or write us at the location listed below.

Grizzly Industrial, Inc.
1203 Lycoming Mall Circle
Muncy, PA 17756
Phone: (570) 546-9663
E-Mail: techsupport@grizzly.com

We want your feedback on this manual. If you can take the time, please email or write to us at the address below and tell us how we did:

Grizzly Industrial, Inc.
c/o Technical Documentation Manager
P.O. Box 2069
Bellingham, WA 98227-2069
Email: manuals@grizzly.com

Machine Description

A jointer is primarily used to flatten the face or edge of a workpiece, which is required when properly "squaring up" a workpiece for later construction or joining multiple pieces with glue. A jointer can also cut bevels, rabbets, and other specialized cuts with various jigs or fixtures.



Identification

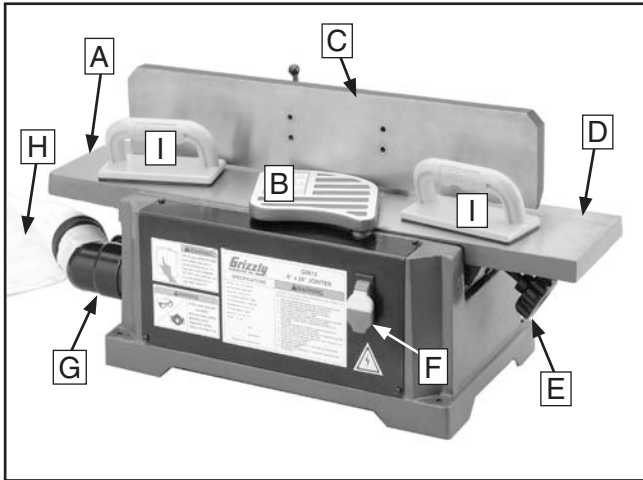

Figure 1. G0612 identification — front view.

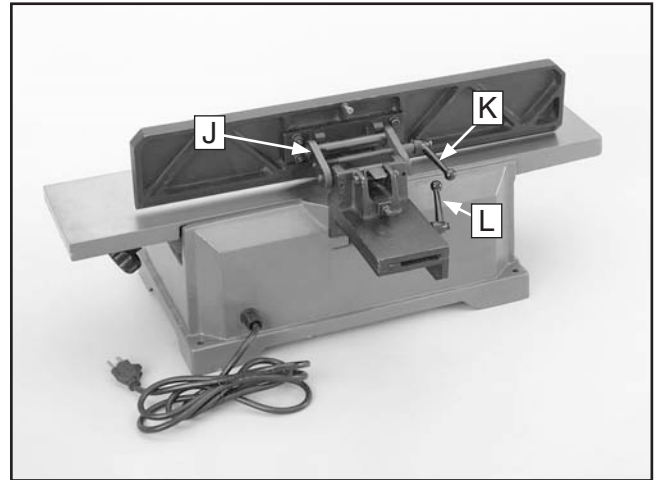

Figure 2. G0612 identification — back view.

- A. Outfeed Table
- B. Cutterhead Guard
- C. Fence
- D. Infeed Table
- E. Depth of Cut Adjusting Knob
- F. ON/OFF Switch
- G. Dust Collection Chute
- H. Dust Collection Bag
- I. Push Blocks

- J. Fence Bracket Assembly
- K. Fence Tilting Handle
- L. Fence Sliding Handle





MACHINE DATA SHEET

Customer Service #: (570) 546-9663 · To Order Call: (800) 523-4777 · Fax #: (800) 438-5901

MODEL G0612 6" X 24" BENCH TOP JOINTER

Product Dimensions:

Weight..... 95 lbs.
 Length/Width/Height..... 24 x 6 x 7-3/4 in.
 Foot Print (Length/Width)..... 11 x 18-7/8 in.

Shipping Dimensions:

Type..... Not Available
 Content..... Machine
 Weight..... 99 lbs.
 Length/Width/Height..... 26 x 8 x 10 in.

Motors:

Main

Type..... Universal
 Horsepower..... 2
 Voltage..... 110
 Prewired..... 110
 Phase..... Single
 Amps..... 12
 Speed..... 20000
 Cycle..... 60
 Number Of Speeds..... 1
 Power Transfer Belt Drive
 Bearings..... Shielded and Lubricated

Main Specifications:

Fence Information

Fence Length..... 22-7/8 in.
 Fence Width..... 3/4 in.
 Fence Height..... 4-5/16 in.
 Fence Stops..... 45 and 90 deg.

Cutting Capacities

Bevel Jointing..... Left & Right 45
 Maximum Width of Cut..... 6 in.
 Maximum Depth of Cut..... 1/8 in.
 Number of Cuts Per Minute..... 20000

Knife Information

Number of Knives..... 2
 Knife Type..... Straight
 Knife Length..... 6-1/2 in.
 Knife Width..... 7/8 in.
 Knife Thickness..... 3/32 in.
 Knife Adjustment..... Jack Screw



Cutterhead Information

Cutterhead Type..... 2 Knife
Cutterhead Diameter..... 1-7/8 in.
Cutterhead Speed..... 10000 RPM

Table Information

Table Length..... 28-1/2 in.
Table Width..... 6-1/4 in.
Floor to Table Height..... 73-1/4 in.
Table Adjustment Type..... Knob
Table Movement Type..... Swing

Construction

Base Construction..... Cast Iron
Body Assembly Construction..... Cast Iron
Cabinet Construction..... Preformed Steel
Fence Assembly Construction..... Cast Iron
Guard Construction..... Aluminum
Table Construction..... Precision Ground Cast Iron
Paint..... Powder Coating

Other Information

Number of Dust Ports..... 1
Dust Port Size..... 2-1/2 in.

Features:

- 45 Degree Inward, 90 and 45 Degree Outward Stops
- Jack Screw Knife Adjustment
- 2-1/2" Dust Port
- 2 Safety Push Blocks
- Dust Collection Fan, Chute and Bag



SECTION 1: SAFETY

WARNING

For Your Own Safety, Read Instruction Manual Before Operating this Machine

The purpose of safety symbols is to attract your attention to possible hazardous conditions. This manual uses a series of symbols and signal words intended to convey the level of importance of the safety messages. The progression of symbols is described below. Remember that safety messages by themselves do not eliminate danger and are not a substitute for proper accident prevention measures.

 **DANGER** Indicates an imminently hazardous situation which, if not avoided, **WILL** result in death or serious injury.

 **WARNING** Indicates a potentially hazardous situation which, if not avoided, **COULD** result in death or serious injury.

 **CAUTION** Indicates a potentially hazardous situation which, if not avoided, **MAY** result in minor or moderate injury. It may also be used to alert against unsafe practices.

NOTICE This symbol is used to alert the user to useful information about proper operation of the machine.

WARNING

Safety Instructions for Machinery

- 1. READ ENTIRE MANUAL BEFORE STARTING.** Operating machine before reading the manual greatly increases the risk of injury.
- 2. ALWAYS USE ANSI APPROVED SAFETY GLASSES WHEN OPERATING MACHINERY.** Everyday eyeglasses only have impact resistant lenses—they are NOT safety glasses.
- 3. ALWAYS WEAR A NIOSH APPROVED RESPIRATOR WHEN OPERATING MACHINERY THAT PRODUCES DUST.** Most types of dust (wood, metal, etc.) can cause severe respiratory illnesses.
- 4. ALWAYS USE HEARING PROTECTION WHEN OPERATING MACHINERY.** Machinery noise can cause permanent hearing loss.
- 5. WEAR PROPER APPAREL. DO NOT** wear loose clothing, gloves, neckties, rings, or jewelry that can catch in moving parts. Wear protective hair covering to contain long hair and wear non-slip footwear.
- 6. NEVER OPERATE MACHINERY WHEN TIRED OR UNDER THE INFLUENCE OF DRUGS OR ALCOHOL.** Be mentally alert at all times when running machinery.



WARNING

Safety Instructions for Machinery

7. **ONLY ALLOW TRAINED AND PROPERLY SUPERVISED PERSONNEL TO OPERATE MACHINERY.** Make sure operation instructions are safe and clearly understood.
8. **KEEP CHILDREN/VISITORS AWAY.** Keep all children and visitors away from machinery. When machine is not in use, disconnect it from power, lock it out, or disable the switch to make it difficult for unauthorized people to start the machine.
9. **UNATTENDED OPERATION.** Leaving machine unattended while its running greatly increases the risk of an accident or property damage. Turn machine **OFF** and allow all moving parts to come to a complete stop before walking away.
10. **DO NOT USE IN DANGEROUS ENVIRONMENTS.** DO NOT use machinery in damp, wet locations, or where any flammable or noxious fumes may exist.
11. **KEEP WORK AREA CLEAN AND WELL LIGHTED.** Clutter and dark shadows may cause accidents.
12. **USE A GROUNDED POWER SUPPLY RATED FOR THE MACHINE AMPERAGE.** Grounded cords minimize shock hazards. Operating machine on an incorrect size of circuit increases risk of fire.
13. **ALWAYS DISCONNECT FROM POWER SOURCE BEFORE SERVICING MACHINERY.** Make sure switch is in OFF position before reconnecting.
14. **MAINTAIN MACHINERY WITH CARE.** Keep blades sharp and clean for best and safest performance. Follow instructions for lubricating and changing accessories.
15. **MAKE SURE GUARDS ARE IN PLACE AND WORK CORRECTLY BEFORE USING MACHINERY.**
16. **REMOVE CHUCK KEYS OR ADJUSTING TOOLS.** Make a habit of never leaving chuck keys or other adjustment tools in/on the machine—especially near spindles!
17. **DAMAGED MACHINERY.** Check for binding or misaligned parts, broken parts, loose bolts, other conditions that may impair machine operation. Always repair or replace damaged parts before operation.
18. **DO NOT FORCE MACHINERY.** Work at the speed for which the machine or accessory was designed.
19. **SECURE WORKPIECE.** Use clamps or a vise to hold the workpiece when practical. A secured workpiece protects your hands and frees both hands to operate the machine.
20. **DO NOT OVERREACH.** Maintain stability and balance at all times when operating machine.
21. **MANY MACHINES CAN EJECT WORKPIECES TOWARD OPERATOR.** Know and avoid conditions that cause the workpiece to "kickback."
22. **STABLE MACHINE.** Machines that move during operations greatly increase the risk of injury and loss of control. Verify machines are stable/secure and mobile bases (if used) are locked before starting.
23. **CERTAIN DUST MAY BE HAZARDOUS** to the respiratory systems of people and animals, especially fine dust. Be aware of the type of dust you are exposed to and always wear a respirator designed to filter that type of dust.
24. **EXPERIENCING DIFFICULTIES.** If at any time you are experiencing difficulties performing the intended operation, stop using the machine! Contact our Technical Support Department at (570) 546-9663.



WARNING

Additional Safety for Jointers

- 1. JOINTER KICKBACK.** "Kickback" is when the workpiece is thrown off the jointer table by the force of the cutterhead. Always use push blocks and safety glasses to reduce the likelihood of injury from "kickback." If you do not understand what kickback is, or how it occurs, **DO NOT** operate this machine.
- 2. CUTTERHEAD ALIGNMENT.** Keep the top edge of the outfeed table aligned with the edge of the cutterhead at top dead center (TDC) to avoid kickback and personal injuries.
- 3. PUSH BLOCKS.** Always use push blocks whenever surface planing. Never pass your hands directly over the cutterhead without a push block.
- 4. WORKPIECE SUPPORT.** Supporting the workpiece adequately at all times while cutting is crucial for making safe cuts and avoiding injury. Never attempt to make a cut with an unstable workpiece.
- 5. KICKBACK ZONE.** The "kickback zone" is the path directly through the end of the infeed table. Never stand or allow others to stand in this area during operation.
- 6. MAXIMUM CUTTING DEPTH.** The maximum cutting depth for one pass is $\frac{1}{8}$ ". Never attempt any single cut deeper than this!
- 7. JOINTING WITH THE GRAIN.** Jointing against the grain or jointing end grain is dangerous and could produce chatter or excessive chip out. Always joint with the grain.
- 8. KEEPING GUARDS IN PLACE.** With the exception of rabbeting, all operations must be performed with the guard in place. After rabbeting, be sure to replace the guard.
- 9. PROPER CUTTING.** When cutting, always keep the workpiece moving toward the outfeed table until the workpiece has passed completely over the cutterhead. Never back the work toward the infeed table.
- 10. USING GOOD STOCK.** Jointing safety begins with your lumber. Inspect your stock carefully before you feed it over the cutterhead. Never joint a board that has loose knots, nails, or staples. If you have any doubts about the stability or structural integrity of your stock, **DO NOT** joint it!

WARNING

Like all machines there is danger associated with this machine. Accidents are frequently caused by lack of familiarity or failure to pay attention. Use this machine with respect and caution to lessen the possibility of operator injury. If normal safety precautions are overlooked or ignored, serious personal injury may occur.

CAUTION

No list of safety guidelines can be complete. Every shop environment is different. Always consider safety first, as it applies to your individual working conditions. Use this and other machinery with caution and respect. Failure to do so could result in serious personal injury, damage to equipment, or poor work results.



SECTION 2: CIRCUIT REQUIREMENTS

110V Operation

⚠️ WARNING

Serious personal injury could occur if you connect the machine to the power source before you have completed the set up process. DO NOT connect the machine to the power source until instructed to do so.

Amperage Draw

The Model G0612 motor draws the following amps under maximum load:

Maximum Load..... 12 Amps

Circuit Requirements

We recommend connecting this machine to a dedicated circuit with a verified ground, using the circuit size given below. Never replace a circuit breaker with one of higher amperage without consulting a qualified electrician to ensure compliance with wiring codes. **If you are unsure about the wiring codes in your area or you plan to connect your machine to a shared circuit, you may create a fire hazard—consult a qualified electrician to reduce this risk.**

Recommended Circuit Size..... 15 Amps

Plug/Receptacle Type

Included Plug/Receptacle..... NEMA 5-15

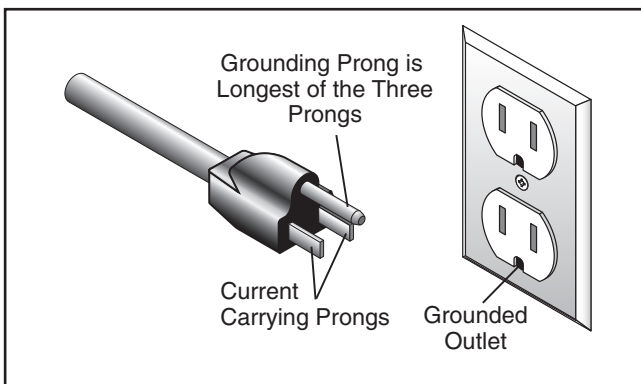
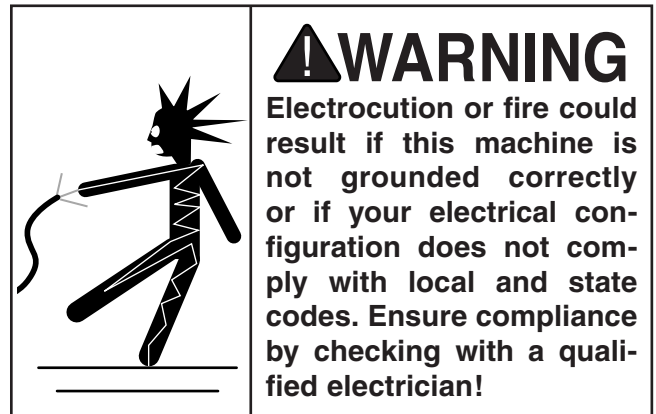

Figure 3. NEMA 5-15 plug and receptacle.

Grounding

In the event of an electrical short, grounding reduces the risk of electric shock. This tool is equipped with a power cord that has a grounding wire, which must be properly connected to the grounding prong on the plug; likewise, the outlet must be properly installed and grounded. All electrical connections must be made in accordance with local codes and ordinances.



Extension Cords

We do not recommend the use of extension cords. Instead, arrange the placement of your equipment and the installed wiring to eliminate the need for extension cords.

If you must use an extension cord at 110V with your machine:

- Use at least a 14 gauge cord that does not exceed 50 feet in length!
- The extension cord must also contain a ground wire and plug pin.
- Avoid cords over 50 feet long unless they have been sized by a qualified electrician.



SECTION 3: SETUP

Setup Safety

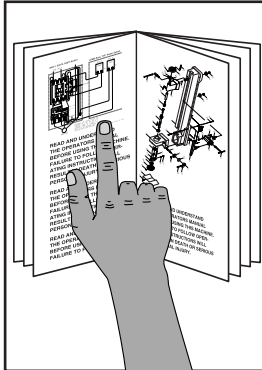

!WARNING
This machine presents serious injury hazards to untrained users. Read through this entire manual to become familiar with the controls and operations before starting the machine!



!WARNING
Wear safety glasses during the entire set up process!

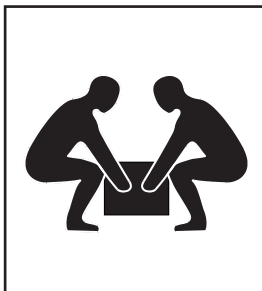

!WARNING
The jointer is heavy (approximately 100 lbs). DO NOT over-exert yourself while unpacking or moving your machine—get assistance.

Unpacking

The Model G0612 was carefully packed when it left our warehouse. If you discover the machine is damaged after you have signed for delivery, please immediately call Customer Service at (570) 546-9663 for advice.

Save the containers and all packing materials for possible inspection by the carrier or its agent. Otherwise, filing a freight claim can be difficult.

When you are completely satisfied with the condition of your shipment, you should inventory the contents.

Items Needed for Setup

The following items, needed to complete the setup process, are not included with your machine.*

DESCRIPTION	Qty
• People for Lifting	As Needed
• Straightedge	1
• Machinist's Combination Square.....	1
• Flat Head Screwdriver.....	1
• Phillips Head Screwdriver	1
• Wrench 10mm	1
• Wrench 8mm	2
• Mounting Hardware	As Needed (See Page 12).
• Degreaser and Rags	As Needed



Inventory

After all the parts have been removed from the box, you should have the following items:

Jointer Box Contents: (Figure 4 & 5)		Qty
A.	Jointer Bed Assembly	1
B.	Fence	1
C.	Dust Collection Bag.....	1
D.	Push Blocks.....	2
E.	Fence Tilting Handle	1
F.	Fence Bracket Assembly	1
G.	Fence Sliding Handle	1
H.	Locking Plate Assembly	1
I.	Fence Support.....	1
J.	Dust Chute	1
K.	Dust Collection Bag Clamp	1

Hardware (Not Shown)		Qty
•	Cap Screws M8-1.25 x 20.....	6
•	Lock Washers 8mm	6
•	Hex Wrench 4mm	1
•	Hex Wrench 6mm	1
•	Pan Head Screw M6-1 x 25.....	1

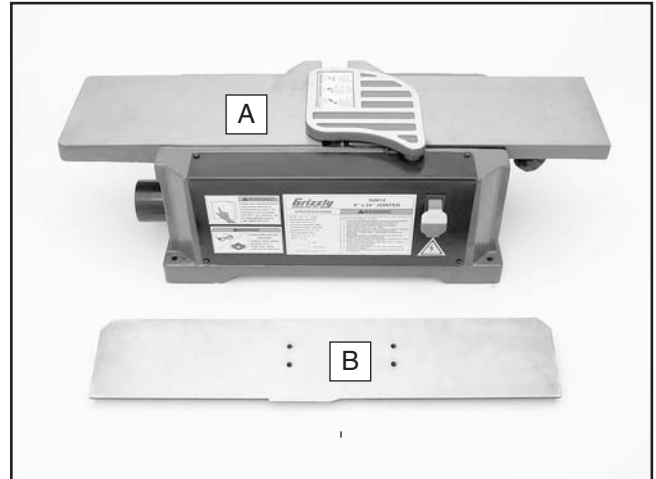

Figure 4. Box contents 1.

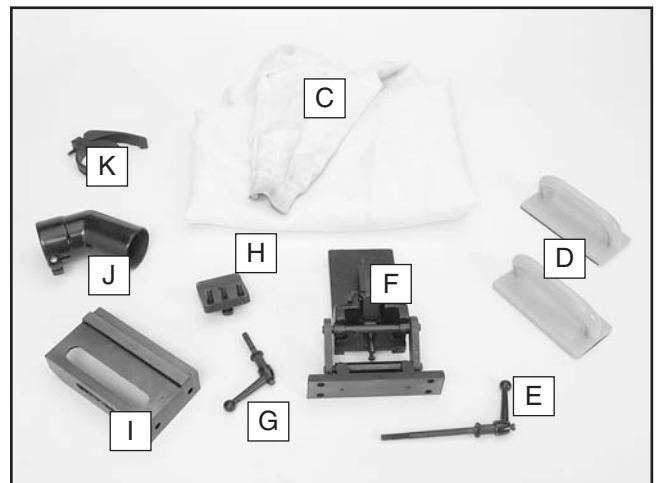

Figure 5. Box contents 2.

In the event that any nonproprietary parts are missing (e.g. a nut or a washer), we would be glad to replace them, or for the sake of expediency, replacements can be obtained at your local hardware store.

NOTICE

Some assembly fasteners may arrive pre-installed on the machine. Check the mounting locations on the machine before assuming that any items from the inventory list are missing.



Cleanup

The unpainted cast iron surfaces are coated with a waxy oil to protect them from corrosion during shipment. Remove this protective coating with a solvent cleaner or citrus-based degreaser such as Grizzly's G7895 Degreaser. To clean thoroughly, some parts may need to be removed. **For optimum performance from your machine, make sure you clean all moving parts or sliding contact surfaces that are coated.** Avoid chlorine-based solvents, such as acetone or brake parts cleaner, as they may damage painted surfaces should they come in contact.

Site Considerations

Consider the jointer dimensions and size of material to be processed through each machine, and space for auxiliary stands, work tables or other machinery when establishing a location for your jointer. See **Figure 6** for the Model G0612 overhead view dimensions.

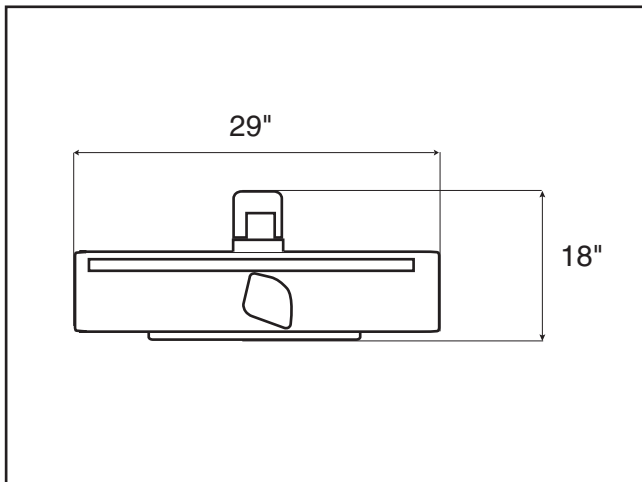

Figure 6. Model G0612 overhead view dimensions.

Mounting the Jointer

Your Model G0612 jointer must be securely mounted to a sturdy workbench. There are two ways to do this—either with a direct mount or with a through mount. We strongly recommend a through mount. Whichever method you choose, mount the jointer through the four holes in its cast iron base. See **Figures 7 and 8** for examples of direct and through mounts.

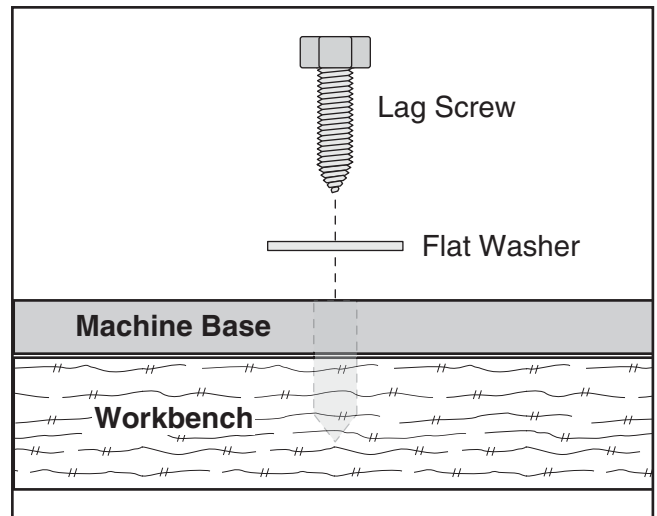

Figure 7. Typical direct mount.

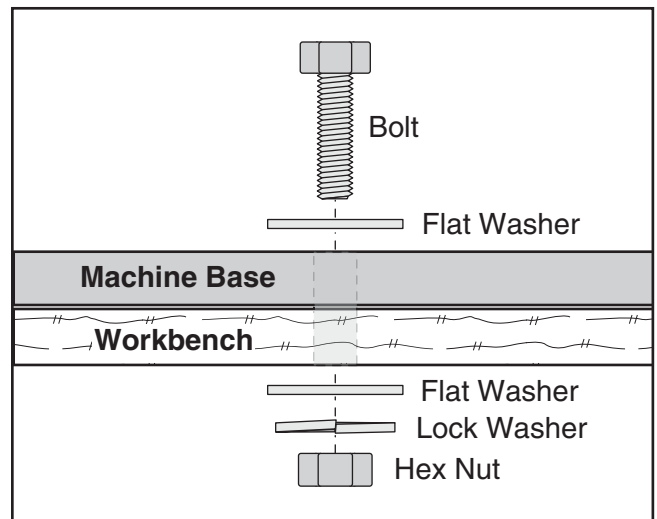

Figure 8. Typical through mount.



Attaching the Fence Support

Components and Hardware Needed:	Qty
Jointer Bed Assembly.....	1
Fence Support.....	1
Locking Plate Assembly	1
Fence Sliding Handle	1
Cap Screws M8-1.25 x 20.....	2
Lock Washers 8mm.....	2
Hex Wrench 6mm.....	1

To attach the fence support:

1. DISCONNECT THE JOINTER FROM POWER SOURCE!
2. Use two cap screws and lock washers to attach the fence support to the jointer bed as shown in **Figure 9**.

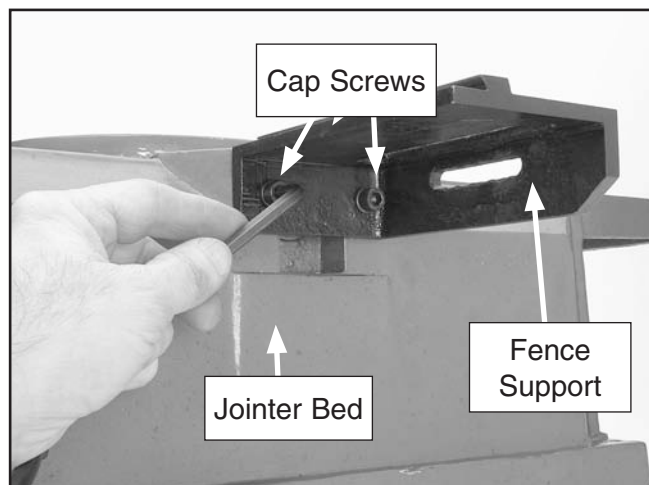

Figure 9. Attaching the fence support to the bed assembly.

3. Insert the locking plate assembly into the fence support, positioning it so the two pins are against the bottom edge of the fence support as shown in **Figure 10**.

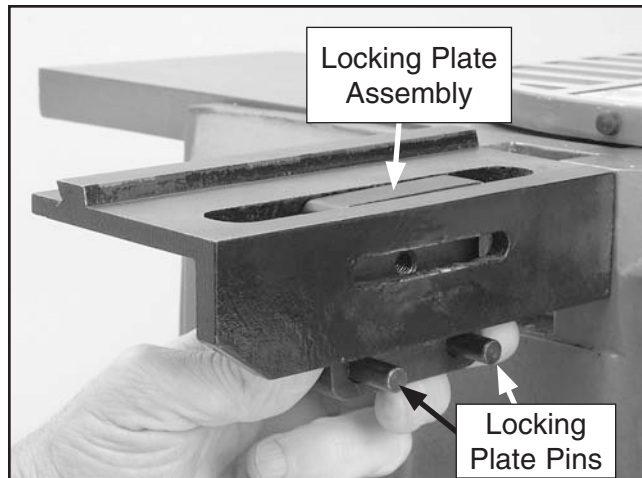

Figure 10. Inserting the locking plate.

4. Secure the locking plate in position with the fence sliding handle as shown in **Figure 11**.

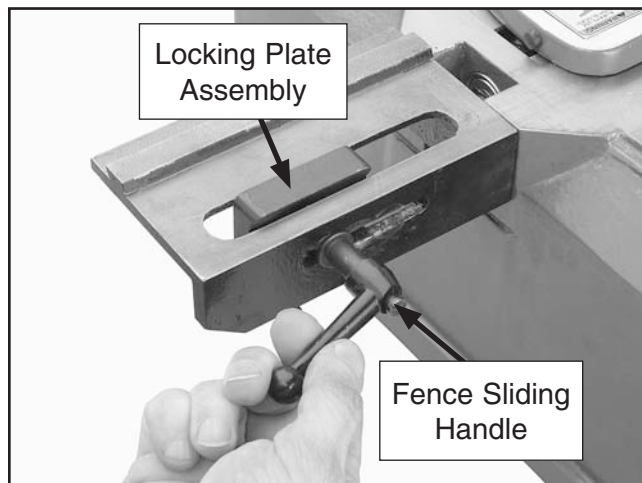

Figure 11. Securing the locking plate assembly with the fence sliding handle.



Installing the Fence

Components and Hardware Needed:	Qty
Jointer Bed Assembly with Fence Support	1
Fence.....	1
Fence Bracket Assembly.....	1
Fence Tilting Handle	1
Cap Screws M8-1.25 x 20.....	4
Lock Washers 8mm.....	4
Hex Wrench 6mm.....	1

To install the fence:

1. Use the four cap screws and washers to attach the fence to the fence bracket assembly, as shown in **Figure 12**.

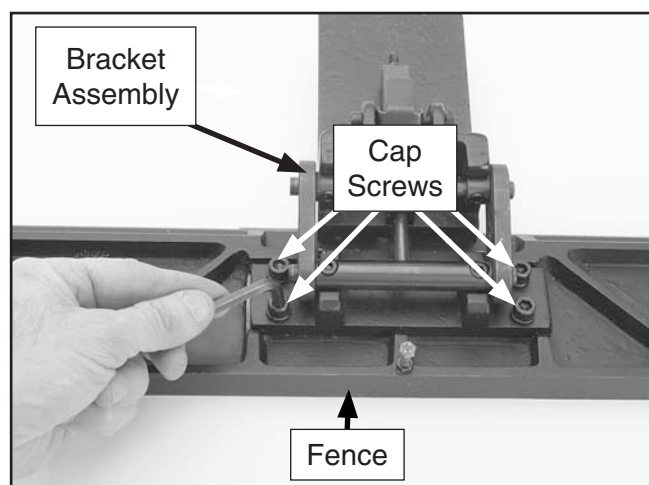

Figure 12. Attaching the fence to the fence bracket assembly.

2. Slide the fence bracket assembly over and onto the dovetails of the support and locking plate as shown in **Figure 13**.

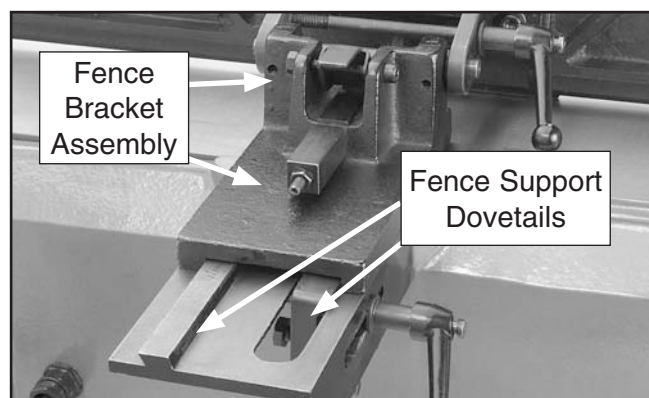

Figure 13. Sliding the fence bracket onto the fence support dovetails.

3. Slide the fence forward until it contacts the cutterhead guard and the cutterhead guard completely covers the cutterhead as shown in **Figure 14**.

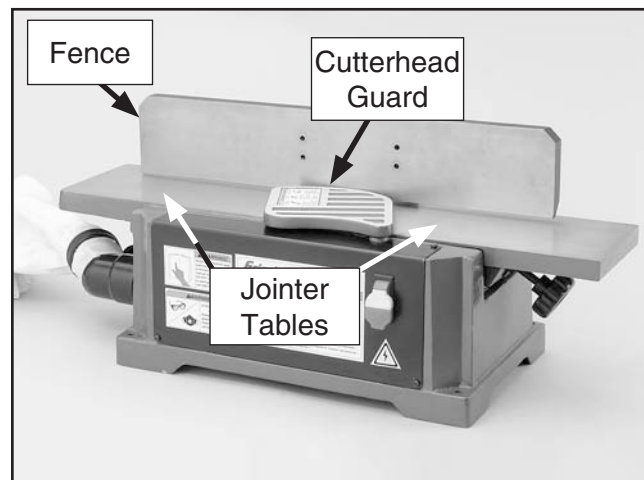

Figure 14. Fence positioned over the jointer tables.

Fence Tilting Handle

Install the fence tilting handle by screwing the handle shaft into the bracket assembly as shown in **Figure 15**.

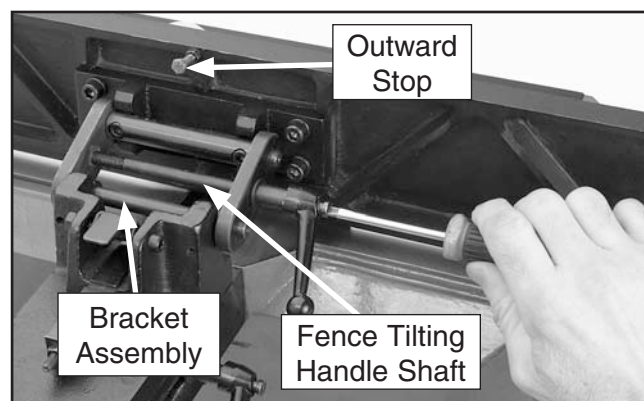

Figure 15. Installing the fence tilting handle.



Checking Outfeed Table Alignment

The outfeed table **MUST** be level with the knives when they are at top dead center (their highest point during rotation) or the workpiece cannot be fed across the jointer safely.

To check the outfeed table alignment:

1. DISCONNECT THE JOINTER FROM THE POWER SOURCE!
2. Place a straightedge on the outfeed table so it extends over the cutterhead. For best results, use a straightedge that will stand on edge without having to be held in place.
3. Rotate the cutterhead under the straightedge, as illustrated in **Figure 16**.

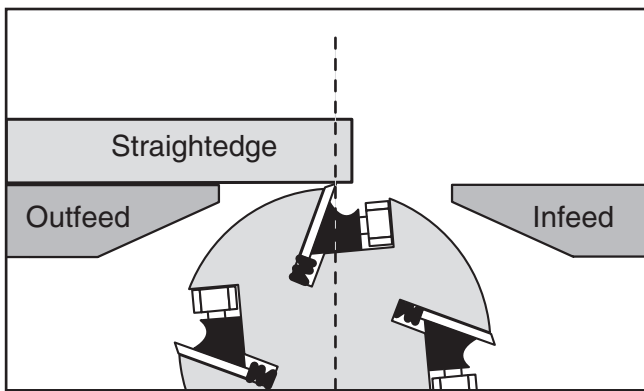

Figure 16. Illustration of a typical cutterhead alignment setup.

—If your cutterhead knives brush the straight edge and move it slightly ($\frac{1}{8}$ ") forward and back when you turn the cutterhead, then no adjustments are necessary.

—If the knives fall below the straightedge and do not move it, or if the knives lift the straightedge and move it more than $\frac{1}{8}$ " , the knives must be adjusted.

To adjust the height of the cutterhead knives:

1. DISCONNECT THE JOINTER FROM THE POWER SOURCE!
2. Block the cutterhead guard back so the cutterhead is fully exposed.
3. Locate the knife clamp screws and knife adjustment jack screws (see **Figures 17 & 18**).

Note: You will perform the procedure in **Steps 1-8** for each of the two knives.

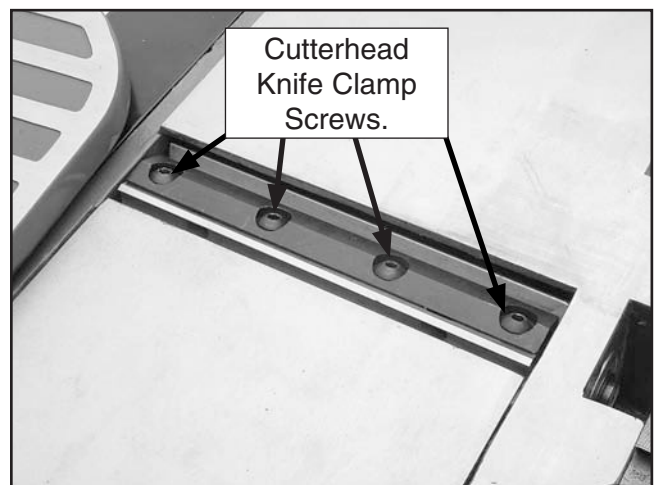

Figure 17. Cutterhead knife clamp screws.

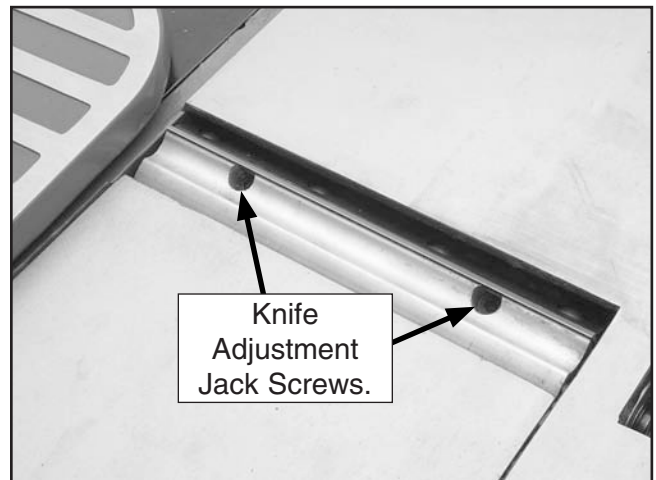

Figure 18. Knife adjustment jack screws.

4. Use a 4mm hex wrench to loosen the four knife clamp screws.



5. Loosen the two jack screws, then, using a scrap wood block, push the knife blade down until both ends are slightly below the straight-edge.
6. Using the 4mm hex wrench, turn each jack screw clockwise $\frac{1}{8}$ of a turn at a time until each end of the knife touches the straight-edge evenly.
7. Rotate the cutterhead without disturbing the knife clamp to check the knife height.
 - If the knife moves the straight edge slightly ($\frac{1}{8}$ ") forward and back on the table, the knife height is set correctly.
 - If the knife does not move the straightedge slightly ($\frac{1}{8}$ ") forward and back on the table, continue to make fine adjustments with the jack screws until the knife is set correctly.
8. When the knife height is set correctly, firmly tighten each of the knife clamp screws. When the clamp is set firmly, tighten the jack screws.

Dust Collection

CAUTION

The Model G0612 creates substantial amounts of wood dust while operating. **DO NOT** operate this machine without an adequate dust collection system. Failure to use a dust collection system can result in short and long-term respiratory illness.

Components and Hardware Needed:	Qty
Dust Chute	1
Dust Collection Bag.....	1
Dust Bag Clamp	1
Phillips Head Screwdriver	1

To Install the dust collection chute and bag:

1. Install the dust chute as shown in **Figure 19**.



Figure 19. Installing the dust chute.



- Slip the bag clamp over the collection bag, then attach the collection bag to the chute and clamp it as shown in **Figure 20**.



Figure 20. Attaching the dust collection bag.

Test Run

Before you begin operations, do **Steps 1-7** below to make sure your jointer is running properly.

	<p>⚠ WARNING</p> <p>Loose hair and clothing could get caught in machinery and cause serious personal injury. Keep loose clothing rolled up and long hair tied up and away from machinery.</p>
--	--

	<p>⚠ WARNING</p> <p>Projectiles thrown from the machine could cause serious eye injury. Wear safety glasses during assembly and operation.</p>
--	---

To test run your jointer:

- Read the entire instruction manual first!

- Make sure the cutterhead guard fully covers the cutterhead.
- Make sure all tools and foreign objects have been removed from the machine.
- Review **SECTIONS 1 and 2 (SAFETY and CIRCUIT REQUIREMENTS)** on **Pages 5-8** and connect your machine to the power source.
- Turn the jointer **ON**.
 - The jointer should run smoothly with little or no vibration.
 - Immediately stop the jointer if you suspect any problems. Refer to **Pages 31 & 32** to troubleshoot and fix any problems before starting the jointer again.
- Turn the jointer OFF, then remove the safety key from the ON/OFF paddle switch.
- Lift the paddle switch to the ON position.
 - If the jointer motor does not start, then the safety key is working properly and you have finished the test run.
 - If the jointer motor starts when the safety key is removed, **IMMEDIATELY DISCONNECT THE JOINTER FROM THE POWER SOURCE**. Refer to **Pages 32 & 33** to troubleshoot the problem.
 - If you still cannot solve this or any other problem that arises during the test run, call Grizzly Tech Support at (570) 546-9663.



SECTION 4: OPERATIONS

Operation Safety

!WARNING

Damage to your eyes, lungs, and ears could result from using this machine without proper protective gear. Always wear safety glasses, a respirator, and hearing protection when operating this machine.

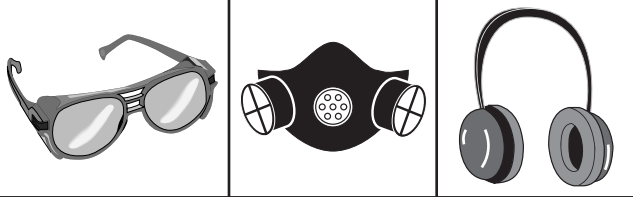

!WARNING

Loose hair and clothing could get caught in machinery and cause serious personal injury. Keep loose clothing and long hair away from moving machinery.

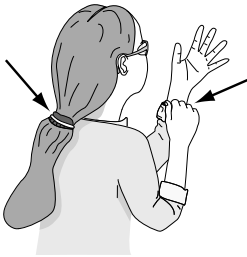

NOTICE

If you have never used this type of machine or equipment before, WE STRONGLY RECOMMEND that you read books, trade magazines, or get formal training before beginning any projects. Regardless of the content in this section, Grizzly Industrial will not be held liable for accidents caused by lack of training.

Basic Parts and Controls

This section covers the basic parts and controls used during routine operations. Refer to **Figures 21** and **22** for basic parts and control locations.

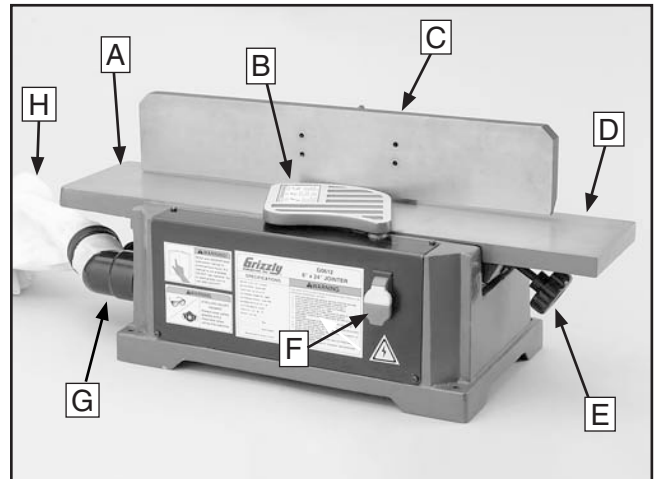

Figure 21. G0612 parts and controls (front view).

- A. Outfeed Table
- B. Cutterhead Guard
- C. Fence
- D. Infeed Table
- E. Depth of Cut Adjusting Knob
- F. ON/OFF Switch
- G. Dust Collection Chute
- H. Dust Collection Bag



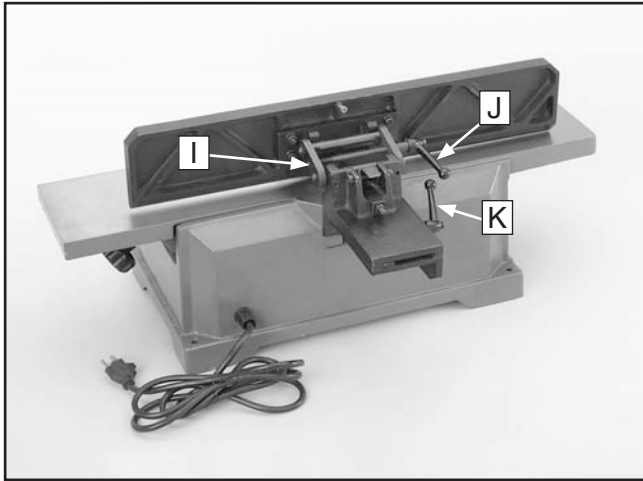

Figure 22. G0612 parts and controls (back view).

- I.** Fence Bracket Assembly
- J.** Fence Tilting Handle
- K.** Fence Sliding Handle

A. Outfeed Table: Supports the workpiece after it passes over the cutterhead.

B. Cutterhead Guard: Shields the cutterhead to increase operator safety during operation. The cutterhead guard is under spring tension; it will always (unless blocked) snap forward to hit the fence. *DO NOT* operate the jointer if the guard is not functioning properly.

C. Fence: The fence guides the workpiece uniformly over the cutterhead at the desired angle.

D. Infeed Table: Supports the workpiece as it is pushed over the cutterhead. The height of the infeed table relative to the cutterhead determines the depth of the cut.

E. Depth of Cut Adjustment Knob: This knob lets you change the height of the infeed table and thus control the depth of cut. Best results are achieved when you limit the maximum depth to $\frac{1}{8}$ " or less when edge jointing and $\frac{1}{32}$ " when surface planing. You can set the depth of cut precisely with this adjustment knob. To determine the depth of stock the cutterhead will remove from your workpiece, place a straightedge across the outfeed table and use a ruler to measure the gap between the straightedge and the infeed table.

F. ON/OFF Switch: This paddle switch starts and stops the cutterhead rotation. The yellow part of the switch is a safety device. When you remove this yellow key (by pulling it forward and out), the switch locks in the *OFF* position. Always remove this yellow key when you leave the jointer work area. Removing the key prevents unsupervised persons in your shop (especially children) from easily or accidentally starting the jointer.

G/H. Dust Collection Chute and Bag: This assembly receives the debris removed from the workpiece as it is cut. The internal fan - powered by the jointer motor - pulls the debris away from the cutterhead and blows it through the chute into the bag.

I. Fence Bracket Assembly: The various parts of this assembly let you change the position of the fence relative to the tables and secure it in position during operation.

J. Fence Tilting Handle: Lets you change the angle of the fence and lock it at the angle desired. The fence can be quickly set to 90° (perpendicular to the tables), 45° inward and 45° outward by setting and using the fence stops on the bracket assembly.

K. Fence Sliding Handle: This handle lets you adjust and lock the position of the fence across the tables. *ALWAYS* firmly tighten the sliding handle before you begin operations. The position of the fence determines the maximum width of the cut as you pass your workpiece over the spinning cutterhead. *NEVER* operate the jointer if *ANY* part of cutterhead is exposed on the work area.



Fence Angle Stops

You can quickly set the fence angle at 90° (perpendicular to the tables), 45° inward, and 45° outward. This section provides instructions for setting the fence stops precisely at these angles.

Before making these adjustments, take a moment to identify the various stop parts of the fence bracket assembly (see **Figure 23**).

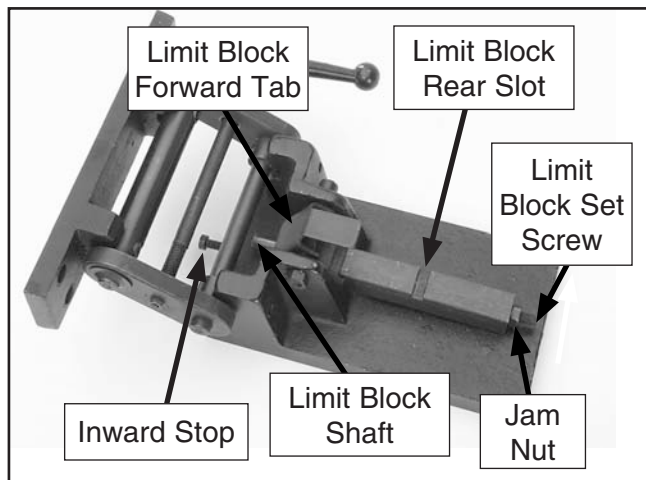

Figure 23. Fence stop parts identification.

To set the 90° stop:

1. DISCONNECT THE JOINTER FROM THE POWER SOURCE!
2. With the fence positioned over the bed and the with the sliding handle locked, loosen the fence tilting handle.
3. Press the forward tab of the limit plate into the rear slot of the limit block.
4. Pull the fence as far as it will go towards 90° (perpendicular to the table), then tighten the fence tilting handle.

Note: When you pull the fence towards 90°, it will stop when it hits the limit block shaft.

5. Use a machinist's combination square to check the angle of the fence as shown in **Figure 24**.



Figure 24. Checking the 90° stop.

—If the fence is perpendicular to the table according to the machinist's square, the 90° stop is set correctly; move ahead to set the 45° stops.

—If the fence is not perpendicular to the table, adjust the 90° stop by doing **Steps 6-9**.



6. Loosen the fence tilting handle, bring the fence to 90° with the machinist's square set against the fence, then tighten the handle.

Note: *Keep the limit plate tab in the rear slot of the limit block.*

7. Loosen the jam nut (located at the rear of the limit block shaft).
8. Using a screwdriver, turn the limit block set screw until the limit block shaft hits the fence.
9. Tighten the jam nut. The 90° stop is now set precisely.

To set the inward 45° stop:

1. DISCONNECT THE JOINTER FROM THE POWER SOURCE!
2. With the fence positioned over the bed and the sliding handle locked, loosen the fence tilting handle.
3. Tip the fence towards the table as far as it will go, then tighten the fence tilting handle.

Note: *When you tip the fence towards the table, it will stop when it hits the inward stop bolt.*

4. Use a machinist's combination square to check the angle of the fence as shown in **Figure 25**.



Figure 25. Checking the inward 45° stop.

—If the fence leans 45° towards the table, the inward 45° stop is set correctly; move ahead to set the outward 45° stop.

—If the fence does not lean 45° towards the table, adjust the inward 45° stop by doing **Steps 5-9**.

5. Loosen the fence tilting handle, bring the fence to 90°, then tighten the handle just enough to keep the fence in position.
6. Remove the limit block from the fence bracket assembly and set it aside.
7. Using two 8mm wrenches, adjust the inward stop bolt (see **Figure 26**) until it hits the fence at precisely 45° inward, then tighten the jam nut (where the bolt meets the bracket assembly) while holding the stop bolt in place. Some trial-and-error will be required to set this stop correctly.

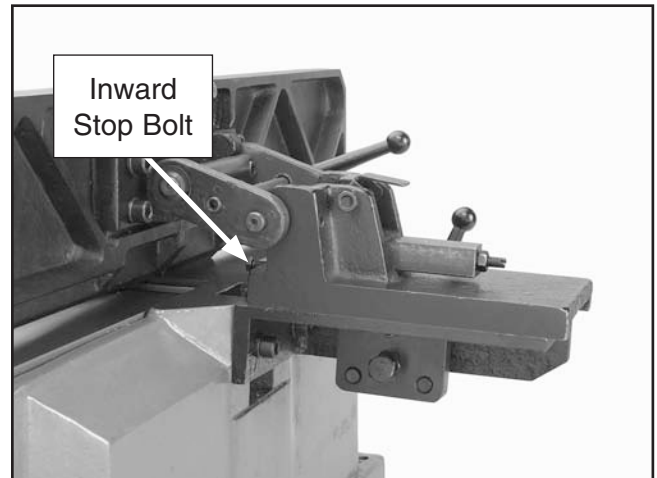

Figure 26. Adjusting the inward stop.



8. Use two 8mm wrenches to tighten the hex nut on the inward stop as you hold the stop in place.
9. Put the limit block back, bring the fence back to 90° and tighten the tilting handle.

To set the outward 45° stop:

1. DISCONNECT THE JOINTER FROM THE POWER SOURCE!
2. Loosen the fence tilting handle, remove the limit block and set it aside.
3. Tip the fence back (away from the table) until it stops.

Note: *The fence will stop when the outward stop bolt hits the fence bracket.*

4. Use a machinist's combination square to check the angle of the fence, as shown in **Figure 27**.



Figure 27. Checking the outward 45° stop.

—If the fence is tilting away from the table at 45°, the outward stop is set correctly. Put the limit block back, bring the fence to 90° and tighten the tilting handle.

—If the fence is not tilting away from the table at 45°, do **Steps 5 & 6** to set the outward stop correctly.

5. With the outward stop bolt resting against the fence bracket, use an 8mm wrench to adjust the length of the stop until the fence is at 45°, then tighten the jam nut (see **Figure 28**).

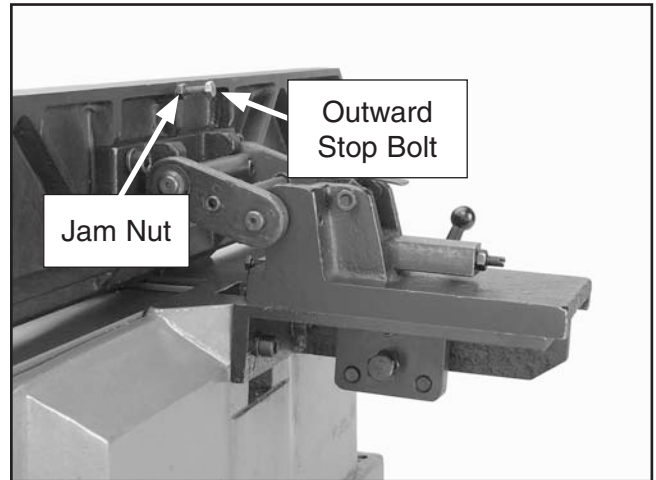

Figure 28. Outward stop bolt detail.

6. Put the limit block back, bring the fence to 90° and tighten the fence tilting handle.

Note: *To ensure accurate results when edge jointing, check the accuracy of these settings frequently (monthly at a minimum) with a machinist's combination square and readjust them if necessary.*



Stock Inspection and Requirements

Here are some rules to follow when choosing and jointing stock:

- **Jointing and surface planing WITH the grain produces a better finish and is safer for the operator.** Cutting with the grain is described as feeding the stock on the jointer so the grain points down and toward you as viewed on the edge of the stock (**Figure 29**).

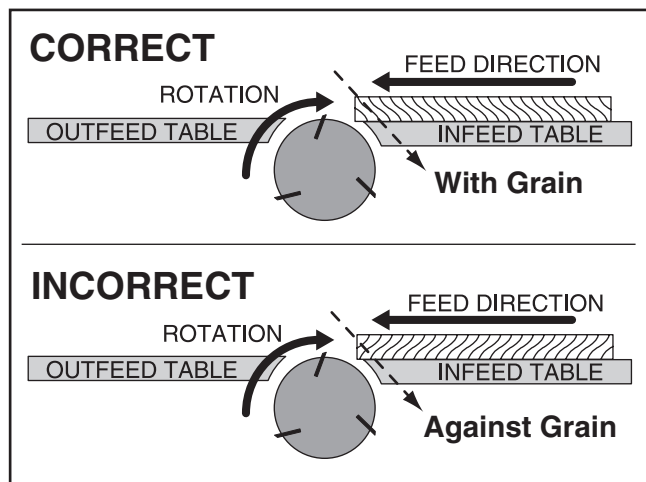

Figure 29. Illustration showing correct and incorrect grain alignment with cutterhead.

Note: If the grain changes direction along the edge of the board, decrease the cutting depth and make additional passes.

- **DO NOT joint or surface plane stock that contains large or loose knots.** Injury to the operator or damage to the workpiece can occur if the knots become dislodged during the cutting operation.
- **DO NOT joint or surface plane against the grain direction.** Cutting against the grain increases the likelihood of stock kickback, as well as tear-out on the workpiece.

- **Remove foreign objects from the stock.** Make sure that any stock you process with the jointer is clean and free of any dirt, nails, staples, tiny rocks or any other foreign objects that may damage the jointer blades.
- **Only process natural wood fiber through your jointer.** Never joint MDF, particle board, plywood, laminates or other synthetically made materials.
- **Make sure all stock is sufficiently dried before jointing.** Wood with a moisture content over 20% will cause unnecessary wear on the knives and poor cutting results.
- **Make sure your workpiece exceeds the minimum dimension requirements (Figures 31 & 30) before edge jointing or surface planing, or it may break or kick back during the operation!**

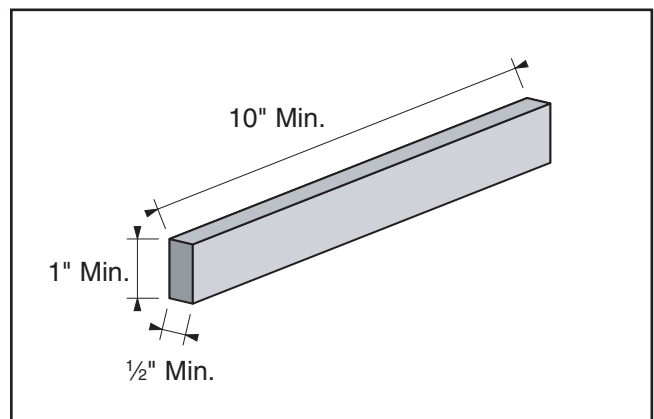

Figure 30. Illustration showing the minimum workpiece dimensions for edge jointing.

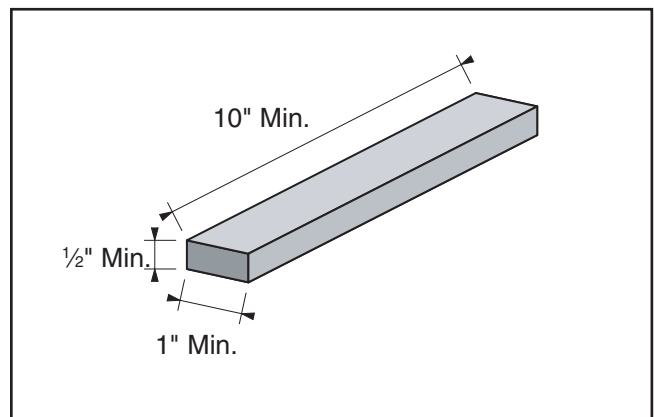

Figure 31. Illustration showing minimum workpiece dimensions for surface planing.



Squaring Stock

Squaring stock involves four steps performed in the order below:

1. Surface Plane on the Jointer—The concave face of the workpiece is surface planed flat with the jointer.

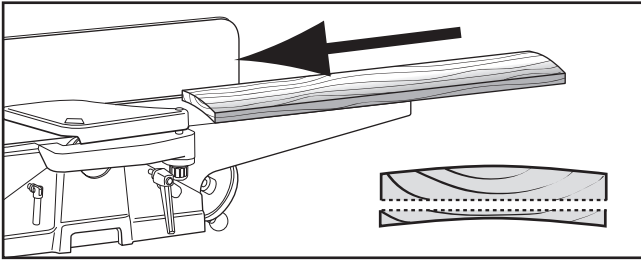

2. Surface Plane on a Thickness Planer—The opposite face of the workpiece is surface planed flat with a thickness planer.

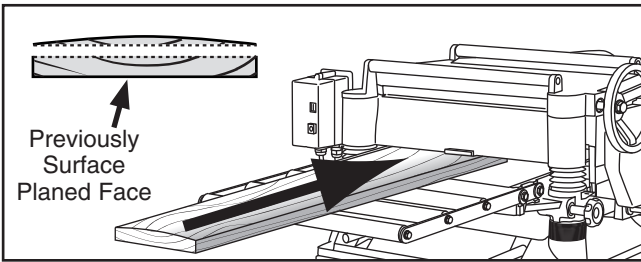

3. Edge Joint On the Jointer—The concave edge of the workpiece is jointed flat with the jointer.

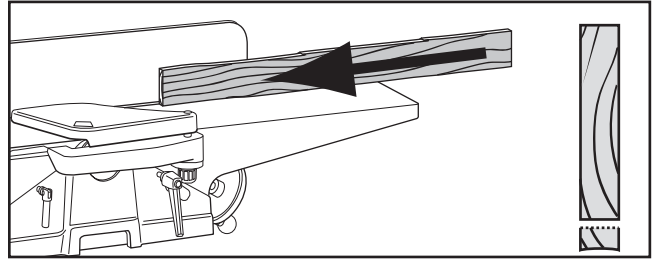

4. Rip Cut on a Table Saw—The jointed edge of the workpiece is placed against a table saw fence and the opposite edge cut off.

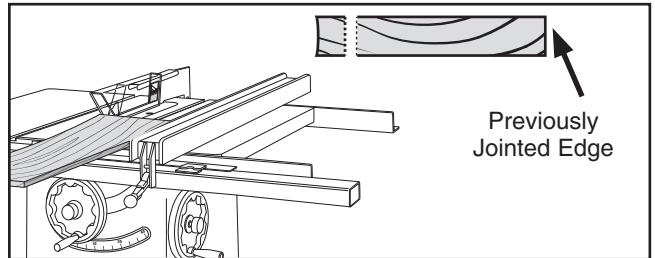

Surface Planing

The purpose of surface planing on the jointer is to make one flat face on the workpiece (see **Figures 32 & 33**) to prepare it for surface planing on a thickness planer.

NOTICE

If you are not experienced with a jointer, set the depth of cut to zero and practice feeding the workpiece across the tables as described. This procedure will better prepare you for the actual operation.



Figure 32. Typical surface planing operation.

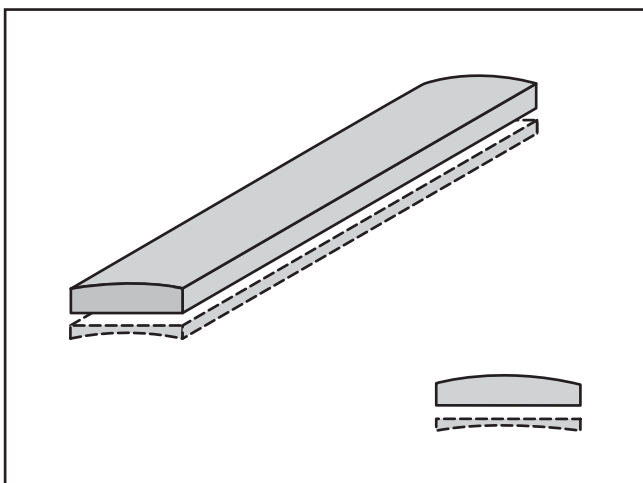

Figure 33. Illustration of surface planing results.

To surface plane on the jointer:

1. Read and understand **SECTION 1: SAFETY**.
2. Make sure you inspect your workpiece for dangerous conditions as described in the **Stock Inspection & Requirements**.
3. Set the cutting depth for your operation. (We suggest $\frac{1}{32}$ " for surface planing.)
4. Make sure your fence is set to 90° .
5. If your workpiece is cupped (warped), place the concave side (**Figure 33**) face down on the surface of the infeed table.
6. Start the jointer.

WARNING

Failure to use push blocks when surface planing may result in cutterhead contact with your hands, which will cause serious personal injury. Always use push blocks to protect your hands when surface planing on the jointer.

7. With a push block in each hand, press the workpiece down on the infeed table and against the fence with firm pressure, then feed the workpiece over the cutterhead, as shown in **Figure 32**.

Note: If your leading hand (with push block) gets within 4" of the cutterhead, lift it up and over the cutterhead, and place the push block on the portion of the workpiece resting on the outfeed table. Now, focus your pressure on the outfeed end of the workpiece while feeding, and repeat the same action with your trailing hand when it gets within 4" of the cutterhead. **DO NOT** place either hand closer than 4" from the cutterhead! Failure to heed this warning could result in serious personal injury.

8. Repeat **Step 7** until the entire surface is flat.



Edge Jointing

The purpose of edge jointing is to produce a finished, flat-edged surface (see **Figure 34**) suitable for joinery or finishing. It is also a necessary step when squaring rough or warped stock.

NOTICE

If you are not experienced with a jointer, set the depth of cut to zero, and practice feeding the workpiece across the tables as described below. This procedure will better prepare you for the actual operation.



Figure 34. Typical edge jointing operation.

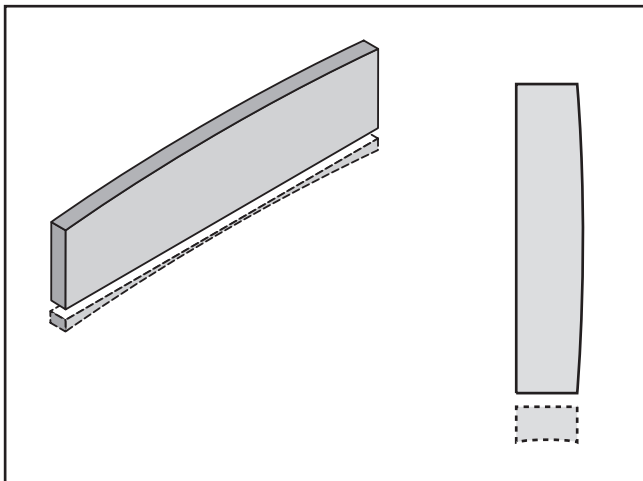

Figure 35. Illustration of edge jointing results.

To edge joint on the jointer:

1. Read and understand **SECTION 1: SAFETY**.
2. Make sure your stock has been inspected for dangerous conditions as described in the **Stock Inspection** instructions.
3. Set the cutting depth for your operation. (We suggest between $\frac{1}{16}$ " and $\frac{1}{8}$ " for edge jointing, using a more shallow depth for hard wood species or for wide stock.)
4. Make sure the fence is set to 90° .
5. If your workpiece is cupped (warped), square the stock before edge jointing by surface planing the workpiece until it is flat on both sides.
6. Start the jointer.
7. Press the workpiece against the infeed table and fence with firm pressure. Use your trailing hand to guide the workpiece through the cut, and feed the workpiece over the cutterhead, as shown in **Figure 34**.

Note: If your leading hand gets within 4" of the cutterhead, lift it up and over the cutterhead, and place it on the portion of the workpiece that is over the outfeed table. Now, focus your pressure on the outfeed end of the workpiece while feeding, and repeat the same action with your trailing hand when it gets within 4" of the cutterhead. To keep your hands safe, **DO NOT** let them get closer than 4" from the cutterhead when it is moving! Failure to heed this warning could result in serious personal injury.

8. Repeat **Step 7** until the entire edge is flat.



Bevel Cutting

The purpose of bevel cutting is to cut the edge of a workpiece at a specific angle (see **Figure 37**).

The Model G0612 has fence stops you can set at 90°, 45° inward, and 45° outward (135°). If your situation requires a different angle, the fence can be locked anywhere between these angles.

NOTICE

If you are not experienced with a jointer, set the depth of cut to zero, and practice feeding the workpiece across the tables as described below. This procedure will better prepare you for the actual operation.



Figure 36. Typical bevel cutting operation.

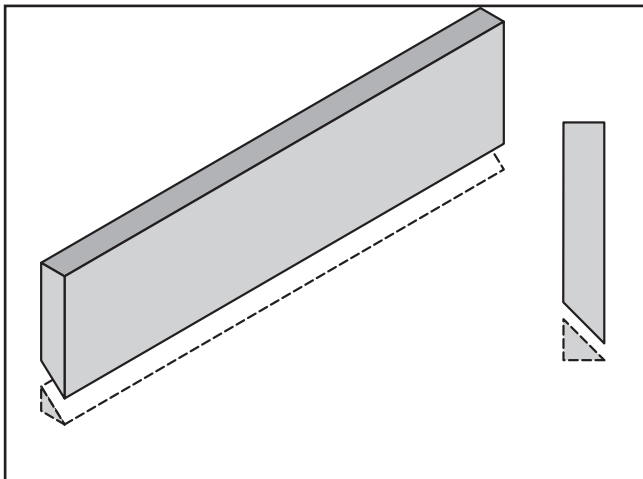

Figure 37. Illustration of bevel cutting results.

To bevel cut on the jointer:

1. Read and understand **SECTION 1: SAFETY**.
2. Make sure your stock has been inspected for dangerous conditions as described in the **Stock Inspection** instructions.
3. Set the cutting depth for your operation. We suggest between $\frac{1}{16}$ " and $\frac{1}{8}$ " for bevel cutting; but use a more shallow depth when cutting hardwoods or wide surfaces.
4. Make sure your fence is set to the angle desired and securely locked.
5. If your workpiece is cupped (warped), square the stock before edge jointing by surface planing the workpiece until it is flat on both sides.
6. Start the jointer.
7. With a push block in your leading hand, press the workpiece against the infeed table and fence with firm pressure, and feed the workpiece over the cutterhead, as shown in **Figure 36**.

Note: *If your leading hand gets within 4" of the cutterhead, lift it up and over the cutterhead, and place it on the portion of the workpiece that is over the outfeed table. Now, focus your pressure on the outfeed end of the workpiece while feeding, and repeat the same action with your trailing hand when it gets within 4" of the cutterhead. To keep your hands safe, DO NOT let them get closer than 4" from the cutterhead when it is moving!*
8. Repeat **Step 7** until the angled cut is satisfactory to your needs.



SECTION 5: ACCESSORIES

**H9837—6" Replacement Jointer Knives
(Set of 2)**

H7828—Shop Fox Tool Table Plus

This new, tool table plus was designed to answer customer requests for a slightly wider and taller table than our G7313 to accommodate a variety of bench-top machines including the G0612 Jointer.



Figure 38. H7828 Shop Fox Tool Table Plus.

G7984—Face Shield

H1298—Dust Sealed Safety Glasses

H1300—UV Blocking, Clear Safety Glasses

H2347—Uvex® Spitfire Safety Glasses

H0736—Shop Fox® Safety Glasses

Safety Glasses are essential to every shop. If you already have a pair, buy extras for visitors or employees. You can't be too careful when it comes to shop safety!

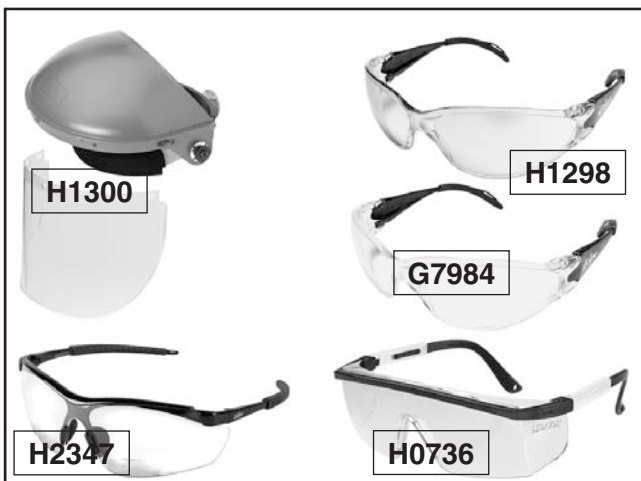

Figure 39. Our most popular safety glasses.

H6175—Power Respirator

H6892—3M Pre-Filter, 10-Pack

H6893—Filter Cartridge, 10-Pack, P100

Say goodbye to foggy safety glasses and labored breathing, this battery powered respirator supplies a constant breeze of fresh air all day long. Comes with its own plastic case for clean, sealed storage. Finally, a respirator you can look forward to wearing—at an affordable price!



Figure 40. H6175 Power Respirator.

G3631—Jointer/Planer Knife Hone

Add a razor hone to your planer and jointer knives with this hand-held sharpening device. This handy tool sharpens flat and beveled surfaces quickly and easily. Great for touch-ups.



Figure 41. G3631 Jointer/Planer Knife Hone.

Call 1-800-523-4777 To Order



- H2499—Small Half-Mask Respirator**
- H3631—Medium Half-Mask Respirator**
- H3632—Large Half-Mask Respirator**
- H3635—Disposable Cartridge Filter Pair P100**

Wood dust is a known carcinogen and has been linked to nasal cancer and severe respiratory illnesses. If you work around dust everyday, a half-mask respirator can be a lifesaver. Also compatible with safety glasses!



Figure 42. Half-mask respirator and disposable cartridge filters.

- G9256—6" Dial Caliper**
- G9257—8" Dial Caliper**
- G9258—12" Dial Caliper**

Required for jointing, planing, or sanding to critical tolerances. These traditional dial calipers are accurate to 0.001" and can measure outside surfaces, inside surfaces, and heights/depths. Features stainless steel, shock resistant construction and a dust proof display. An absolute treat for the perfectionist!

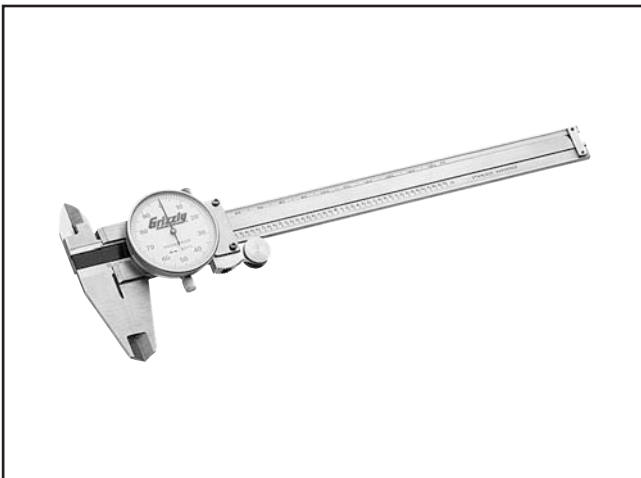

Figure 43. Grizzly® Dial Calipers.

H1411—PowerHands™ Safety Stick

This safety push stick features interchangeable traction treads; one for flat stock, and one for pressing against table and fence. It also has a spring loaded push-pin for full workpiece contact. Made in the USA.



Figure 44. H1411 PowerHands™ Safety Stick.

- G9643—8" Precision Straightedge**
- G9644—12" Precision Straightedge**
- H2675—16" Precision Straightedge**

These grade 00 heavy-duty stainless steel straightedges are manufactured to DIN874 standards for professional results in set-up and inspection work.



Figure 45. Straightedges.

Call 1-800-523-4777 To Order



SECTION 6: MAINTENANCE



Schedule

For optimum performance from your machine, follow this maintenance schedule and refer to any specific instructions given in this section.

Daily Check

- Vacuum all dust on and around the machine.
- Empty debris from the dust collection bag. DO NOT use the jointer if debris obstructs the flow of material into the bag. Using the jointer when the chute is obstructed can lead to jointer malfunction and, possibly, fire. Failure to heed this warning can result in serious personal injury.
- Wipe down tables and all other unpainted cast iron with a metal protectant.

Monthly Check

- Fence angle stops and cutterhead knife alignment.
- Belt tension, damage, or wear.
- Clean/vacuum dust from inside the cabinet and around the motor.

Belts

Belts must be in good condition (free from cracks, fraying and wear), and correctly adjusted. Replacement belts can be ordered from Grizzly. The part number for the cutterhead drive belt is P0612070. The part number for the fan belt is P0612092.

Cleaning

Cleaning the Model G0612 is easy and should be done often. Vacuum excess wood chips and sawdust, and wipe off the remaining dust away with a dry cloth. If any resin has built up, use a resin dissolving cleaner to remove it.

Protect the unpainted cast iron surfaces on the table by wiping the table clean after every use—this will help prevent moisture from wood dust accumulating on bare metal surfaces.

Keep tables rust-free with regular applications of products like G96® Gun Treatment, SLIPIT®, or Boeshield® T-9.

Lubrication

All bearings are sealed and permanently lubricated. Do not lubricate them; leave them alone until they need to be replaced.



SECTION 7: SERVICE

Review the troubleshooting and procedures in this section to fix or adjust your machine if a problem develops. If you need replacement parts or you are unsure of your repair skills, then feel free to call our Technical Support at (570) 546-9663.

Troubleshooting

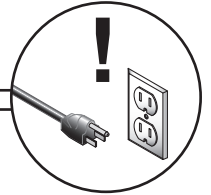

Motor and Electrical

Symptom	Possible Cause	Possible Solution
Machine does not start or a breaker trips.	<ol style="list-style-type: none"> 1. Safety key removed from ON/OFF switch, 2. Plug/receptacle is at fault or wired incorrectly. 3. Power supply is at fault/switched OFF. 4. Lockout key is at fault. 5. Motor brushes are at fault. 6. Motor ON/OFF switch is at fault. 7. Wiring is open/has high resistance. 8. Motor is at fault. 	<ol style="list-style-type: none"> 1. Replace safety key. 2. Test for good contacts; correct the wiring. 3. Ensure hot lines have correct voltage on all legs and main power supply is switched ON. 4. Install/replace lockout key; replace switch. 5. Remove/replace brushes. 6. Replace faulty ON/OFF switch. 7. Check for broken wires or disconnected/corroded connections, and repair/replace as necessary. 8. Test/repair/replace.
Machine stalls or is underpowered.	<ol style="list-style-type: none"> 1. Wrong workpiece material (wood). 2. Cutterhead belt slipping. 3. Plug/receptacle is at fault. 4. Motor brushes are at fault. 5. Motor bearings are at fault. 6. Machine is undersized for the task. 7. Knives dull, feed rate is too fast depth of cut too great. 8. Motor has overheated. 9. Motor is at fault. 	<ol style="list-style-type: none"> 1. Use wood with correct moisture content, without glues, and little pitch/resins. 2. Replace cutterhead belt and re-tension. 3. Test for good contacts; correct the wiring. 4. Remove/replace brushes. 5. Test by rotating shaft; rotational grinding/loose shaft requires bearing replacement. 6. Stop operation. 7. Use sharp knives; reduce feed rate/depth of cut. 8. Clean off motor, let cool, and reduce workload. 9. Test/repair/replace.
Machine has vibration or noisy operation.	<ol style="list-style-type: none"> 1. Motor or component is loose. 2. Knife blades, clamp or jack screws are at fault. 3. Belts worn or loose. 4. Motor fan is rubbing on fan cover. 5. Loose mounting bolts. 6. Blade is at fault. 	<ol style="list-style-type: none"> 1. Inspect/replace stripped or damaged bolts/nuts, and re-tighten with thread locking fluid. 2. Resharpener/replace knives as required; set knife alignment correctly. 3. Inspect/replace belts with a new ones. 4. Replace dented fan cover; replace loose/damaged fan. 5. Replace/tighten as required. 6. Replace warped, bent, or twisted blade; resharpen dull blade.





Cutting Operations

Symptom	Possible Cause	Possible Solution
Excessive snipe (gouge in the end of the board that is uneven with the rest of the cut).	<ol style="list-style-type: none"> 1. Outfeed table is out of alignment with the cutterhead. 2. Operator is pushing down on trailing edge of the workpiece 	<ol style="list-style-type: none"> 1. Align cutterhead with outfeed table. 2. Reduce/eliminate downward pressure on that end of the workpiece.
Cutterhead stops during operation.	<ol style="list-style-type: none"> 1. Cutterhead belt is damaged/broken. 	<ol style="list-style-type: none"> 1. Replace cutterhead belt.
Workpiece stops in the middle of the cut.	<ol style="list-style-type: none"> 1. Cutterhead is set lower than the outfeed table. 	<ol style="list-style-type: none"> 1. Align outfeed table with cutterhead knife at top dead center.
Chipping.	<ol style="list-style-type: none"> 1. Knots or conflicting grain direction in wood. 2. Nicked or chipped knives. 3. Feeding workpiece too fast. 4. Taking too deep of a cut. 	<ol style="list-style-type: none"> 1. Inspect workpiece for knots and grain; only use clean stock. 2. Adjust one of the nicked knives sideways; sharpen or replace blade. 3. Slow down the feed rate. 4. Take a smaller depth of cut. Never exceed 1/8" per pass. Reduce cutting depth when working with hard woods.
Long lines or ridges that run along the length of the board.	<ol style="list-style-type: none"> 1. Nicked or chipped knives. 	<ol style="list-style-type: none"> 1. Adjust one of the nicked knives sideways; sharpen or replace blade.
Uneven cutter marks, wavy surface, or chatter marks across the face of the board.	<ol style="list-style-type: none"> 1. Feeding workpiece too fast. 2. Knives not adjusted evenly with each other in the cutterhead. 	<ol style="list-style-type: none"> 1. Slow down the feed rate. 2. Adjust the knives so they are set up evenly with the cutterhead.
Board edge is concave or convex after jointing.	<ol style="list-style-type: none"> 1. Board not held with even pressure on infeed and outfeed table during cut. 2. Board started too uneven. 3. Board has excessive bow or twist along its length. 4. Insufficient number of passes. 	<ol style="list-style-type: none"> 1. Hold board with even pressure as it moves over the cutterhead. 2. Take partial cuts to remove the extreme high spots before doing a full pass. 3. Surface plane one face so there is a good surface to position against the fence. 4. It may take 3 to 5 passes to achieve a perfect edge, depending on the starting condition of the board and the depth of cut.
Overall, cut quality is poor; inconsistent snipe problems; or consistent difficulty feeding workpiece.	<ol style="list-style-type: none"> 1. Knives are out of alignment or cutterhead height is not even with the outfeed table. 2. Jointer stops are set incorrectly. 3. Fence bracket parts are loose or parts are misaligned. 	<ol style="list-style-type: none"> 1. Reset the knives to correct height and alignment with cutterhead assembly. 2. Recalibrate the fence stops. 3. Check/tighten the fence bracket fasteners.



Adjusting/Replacing Belts

Your G0612 uses belts to drive both the cutterhead and the dust collection fan. When these belts are not tensioned correctly, misaligned, or damaged your jointer will not function properly.

This sub-section describes how to service these belts. You can order replacement belts from Grizzly. The part number for the drive belt is: P0612070; the part number for the impeller belt is P0612092.

Refer to the parts diagram in this manual when fixing belt problems. If you need further assistance from Grizzly, call our Tech Support at (570) 546-9663.

To realign or replace the cutterhead belt:

1. DISCONNECT THE JOINTER FROM THE POWER SOURCE!
2. While facing the rear of the jointer, tip it away from you until it rests on the fence assembly.
3. Remove the Phillips screws fastening the motor cover to the jointer base. Lift the cover off and set it aside.
4. Remove all dust and debris from the motor and belt areas.
5. Inspect the cutterhead belt for proper tension, alignment and condition.

Note: The belt is properly tensioned if it deflects no more than $\frac{3}{4}$ " when you press down on middle of the belt with moderate pressure from your thumb or forefinger.

The belt is properly aligned if it lies flat and straight on the motor shaft and drive pulley.

Belt damage will be evident on inspection.

6. Loosen the four motor mounting cap screws(see Figure 46), but do not remove them.

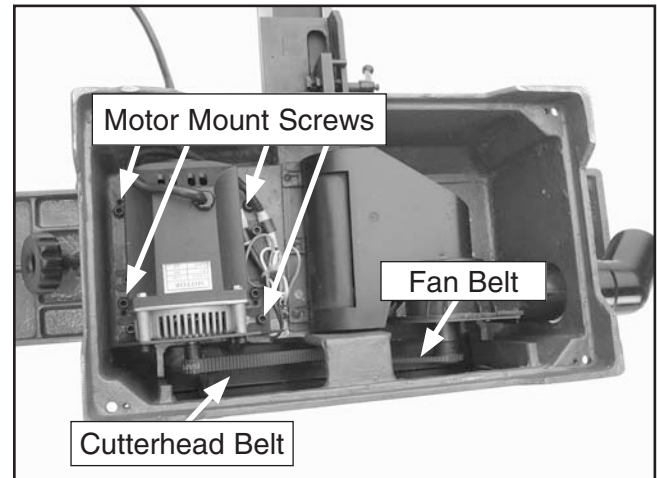

Figure 46. Motor mounting screws and belt locations.

7. Replace a damaged belt with a new one. Realign and retension the belt.
8. Tighten the motor mounting screws and replace the motor cover.
9. Test run the jointer. Repeat this procedure if necessary. If repeating this procedure does not solve the problem, call Grizzly Tech Support.

To replace the fan belt:

1. DISCONNECT THE JOINTER FROM THE POWER SOURCE!
2. Remove the motor cover, set it aside and check the belt for damage.

Note: It is highly unlikely that this belt will ever be misaligned or out of tension. If it is, the jointer needs to be serviced by a qualified technician. Call our Tech Support for assistance at (570) 546-9663.

3. If the belt is damaged, put one end of the new belt on the fan pulley, then fit the other end onto the drive pulley.
4. Replace the motor cover and secure it with the Phillips screws.



Replacing Motor Brushes

Your jointer has a single phase universal motor that uses carbon brushes. Under normal operation these brushes wear out. Refer to the troubleshooting guide to determine if the motor brushes must be replaced.

You can order a new brush kit (two brush assemblies) from Grizzly. The part number for the brush kit is P0612024-1.

Refer to the parts diagram in this manual when replacing worn brushes. If you need assistance call Grizzly Tech Support at (570) 546-9663.

To replace motor brushes:

1. DISCONNECT THE JOINTER FROM THE POWER SOURCE.
2. While facing the rear of the jointer, tip it away from you until it rests on the fence assembly.
3. Remove the four Phillips screws fastening the motor cover to the jointer base. Lift the cover and set it aside.
4. Take this opportunity to clear dust and debris from inside the jointer.
5. Use a dime to unscrew the brush caps. (See **Figure 47** to locate the brush caps.)

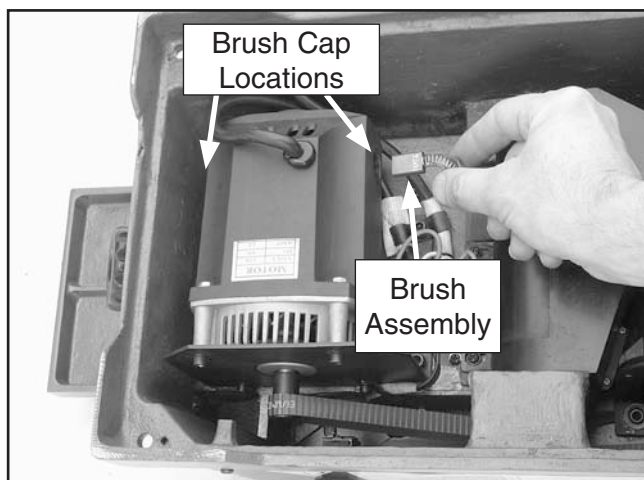

Figure 47. Removing a motor brush.

Note: When you remove the brush caps a spring will pop out of the socket; the carbon brush is firmly attached to this spring. When you buy a new brush kit you will get a pair of brush/spring assemblies.

6. Check the brushes for wear. If a brush is worn to less than $\frac{3}{32}$ " in length, replace both brushes.
7. Insert the brush assemblies, positioning them so they slide into the slots built into the sockets.
8. Press the brush cap against the spring, push it into the socket and turn the brush cap to lock it in the motor housing.
9. Replace the motor cover and tighten the Phillips screws.
10. Test run the jointer.

— If the jointer runs properly, you are done.

— If the motor does not start, either the brushes are not correctly aligned in the sockets or there is another problem with the motor or wiring. Refer to the **Troubleshooting** section for assistance.



Wiring Diagram



This wiring diagram can be viewed online in full color at www.grizzly.com.

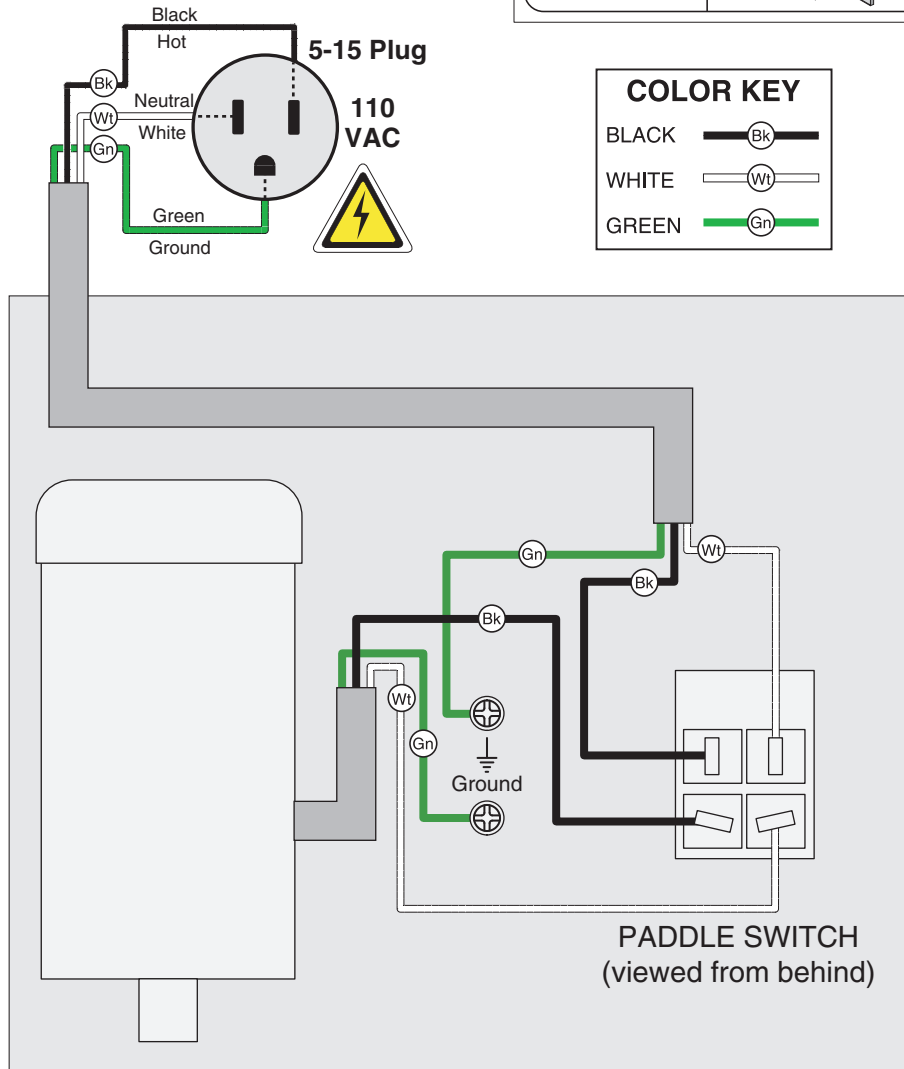
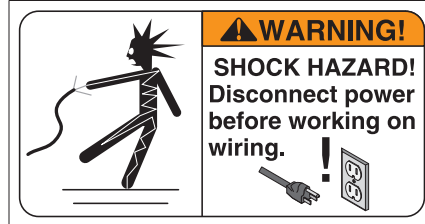

Parts Breakdown

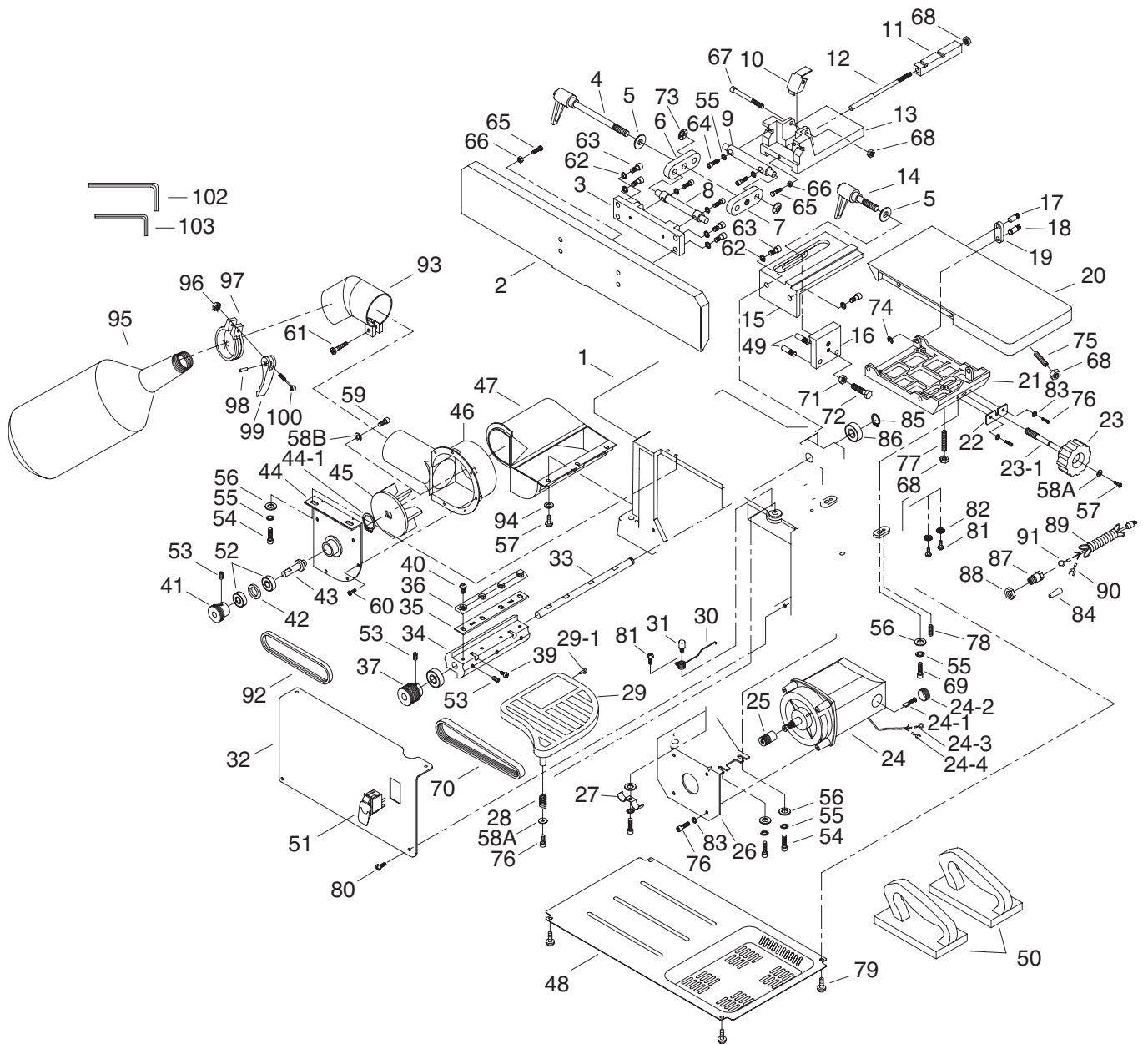

Parts List

1	P0612001	BASE
2	P0612002	FENCE
3	P0612003	FENCE PLATE
4	P0612004	HANDLE
5	PW01M	FLAT WASHER 8MM
6	P0612006	RIGHT LINK
7	P0612007	LEFT LINK
8	P0612008	PLATE SHAFT
9	P0612009	BRACKET SHAFT
10	P0612010	LIMIT PLATE
11	P0612011	BLOCK
12	P0612012	SHAFT
13	P0612013	FENCE BRACKET
14	P0612014	HANDLE
15	P0612015	FENCE SUPPORT
16	P0612016	LOCKING PLATE
17	P0612017	TABLE PIN
18	P0612018	FRAME PIN
19	P0612019	BRACKET
20	P0612020	INFEED TABLE
21	P0612021	TABLE FRAME
22	P0612022	SUPPORT PLATE
23	P0612023	HANDLE
23-1	P0612023-1	HANDLE SHAFT
24	P0612024	2 HP UNIVERSAL MOTOR
24-1	P0612024-1	CARBON BRUSH SET (2)
24-2	P0612024-2	BRUSH COVER
24-3	P0612024-3	RING TERMINAL
24-4	P0612024-4	SPADE TERMINAL
25	P0612025	MOTOR PULLEY
26	P0612026	MOTOR MOUNTING PLATE
27	P0612027	CORD CLAMP
28	P0612028	COMPRESSION SPRING
29	P0612029	BLADE GUARD
29-1	P0612029-1	RUBBER BUMPER
30	P0612030	TORSION SPRING
31	P0612031	PIN
32	P0612032	SHEET IRON COVER
33	P0612033	SHAFT
34	P0612034	CUTTERHEAD
35	P0612035	BLADE
36	P0612036	BLADE CLAMP
37	P0612037	DRIVE PULLEY
39	P0612039	JACK SCREW
40	PSB115M	BUTTON HD CAP SCR M6-1 X 16
41	P0612041	FAN PULLEY
42	P0612042	SPACER
43	P0612043	FAN SHAFT
44	P0612044	CHIP BLOWER MOUNTING PLATE
44-1	PR17M	EXT RETAINING RING 26MM
45	P0612045	IMPELLER
46	P0612046	CHIP EXHAUST
47	P0612047	CHIP COLLECTOR
48	P0612048	COVER
49	P0612049	PIN

50	P0612050	PUSH BLOCK
51	P0612051	PADDLE SWITCH
52	P6000	BALL BEARING 6000ZZ
53	PSS01M	SET SCREW M6-1 X 10
54	PSB26M	CAP SCREW M6-1 X 12
55	PLW03M	LOCK WASHER 6MM
56	PW03M	FLAT WASHER 6MM
57	PS09M	PHLP HD SCR M5-.8 X 10
58A	PW02M	FLAT WASHER 5MM
58B	P0612058B	FENDER WASHER 5MM
59	PSB33M	CAP SCREW M5-.8 X 12
60	P0612060	TAP SCREW M4.2 X 10
61	PS26M	PHLP HD SCR M6-1 X 20
62	PLW04M	LOCK WASHER 8MM
63	PSB14M	CAP SCREW M8-1.25 X 20
64	PSB02M	CAP SCREW M6-1 X 20
65	PB94M	HEX BOLT M5-.8 X 25
66	PN06M	HEX NUT M5-.8
67	PSB37M	CAP SCREW M6-1 X 50
68	PN01M	HEX NUT M6-1
69	PSB07M	CAP SCREW M6-1 X 30
70	P0612070	CUTTERHEAD BELT 171J5 NK
71	PN03M	HEX NUT M8-1.25
72	PB20M	HEX BOLT M8-1.25 X 35
73	P0612073	PUSH NUT M10
74	PEC09M	E-CLIP 6MM
75	PSS28M	SET SCREW M6-1 X 30
76	PSB07M	CAP SCREW M6-1 X 30
77	PSS29M	SET SCREW M6-1 X 35
78	PSS11M	SET SCREW M6-1 X 16
79	PS05M	PHLP HD SCR M5-.8 X 8
80	PS05M	PHLP HD SCR M5-.8 X 8
81	PS38M	PHLP HD SCR M4-.7 X 10
82	P0612082	SERRATED WASHER 4MM
83	PLW01M	LOCK WASHER 5MM
84	P0612084	WIRE NUT
85	PR03M	EXT RETAINING RING 12MM
86	P6201	BALL BEARING 6201ZZ
87	P0612087	STRAIN RELIEF
88	P0612088	PLASTIC NUT
89	P0612089	LINE CORD
90	P0612024-4	SPADE TERMINAL
91	P0612024-3	RING TERMINAL
92	P0612092	FAN BELT V1.25-7A
93	P0612093	DUST CHUTE
94	PW02M	FLAT WASHER 5MM
95	P0612095	DUST COLLECTER BAG
96	PN01M	HEX NUT M6-1
97	P0612097	CLAMP 60MM
98	P0612098	PIN
99	P0612099	TIGHTENING HANDLE
100	P0612100	SWING BRACE M6 X 50MM
102	PAW06M	HEX WRENCH 6MM
103	PAW04M	HEX WRENCH 4MM



Safety Label Parts List

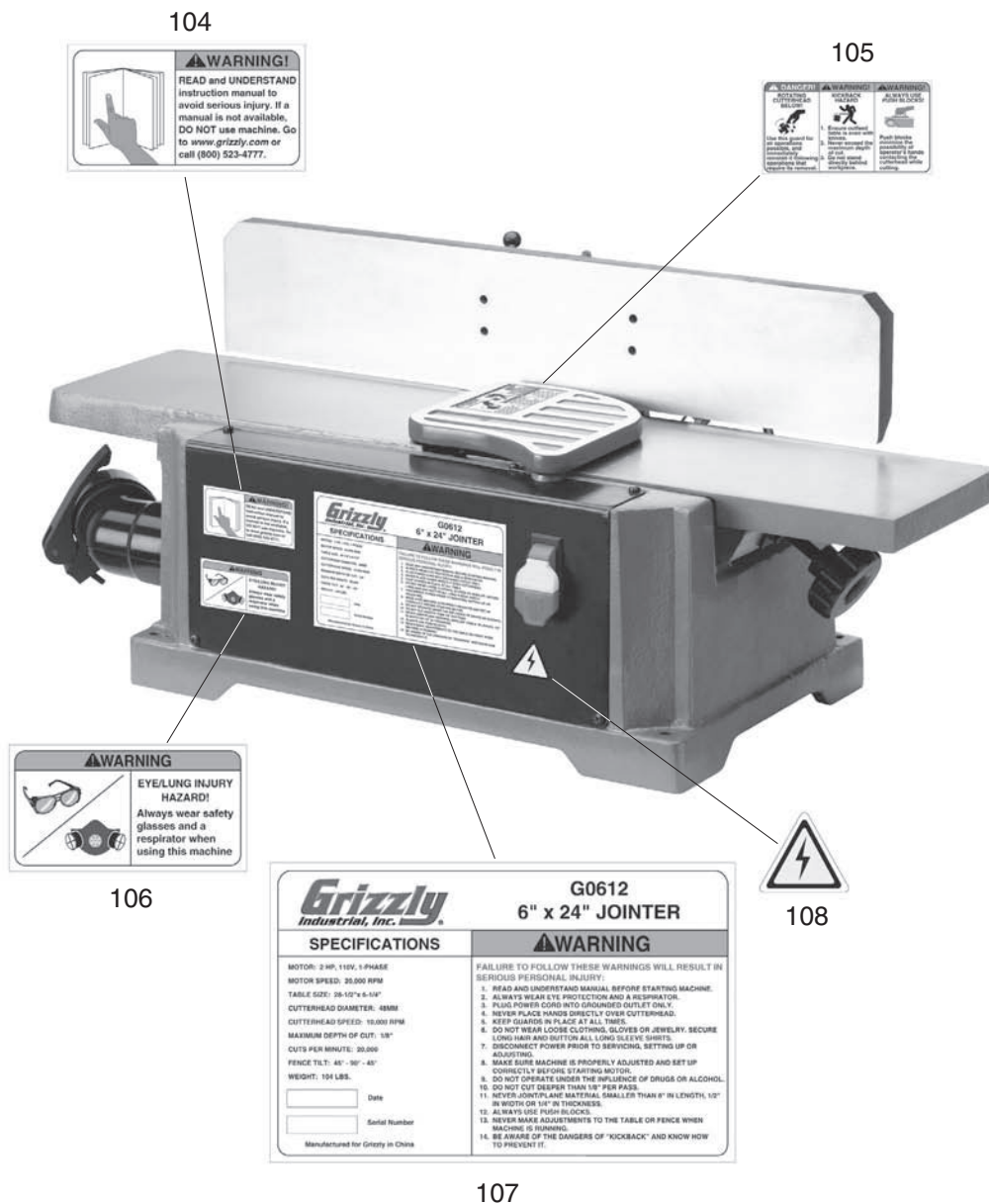

104

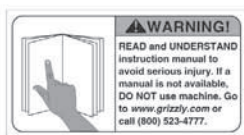

105

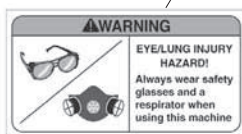

106



108

107

REF	PART #	DESCRIPTION	REF	PART #	DESCRIPTION
104	PLABEL-12B	READ MANUAL LABEL-HORZ	107	P0612107	MACHINE ID LABEL
105	P0612105	CUTTERHEAD GUARD LABEL	108	PLABEL-14	ELECTRICITY LABEL
106	P0612106	EYE/LUNG HAZARD LABEL			

WARNING

Safety labels warn about machine hazards and ways to prevent injury. The owner of this machine **MUST** maintain the original location and readability of the labels on the machine. If any label is removed or becomes unreadable, **REPLACE** that label before using the machine again. Contact Grizzly at (800) 523-4777 or www.grizzly.com to order new labels.





WARRANTY CARD

Name _____
 Street _____
 City _____ State _____ Zip _____
 Phone # _____ Email _____ Invoice # _____
 Model # _____ Order # _____ Serial # _____

The following information is given on a voluntary basis. It will be used for marketing purposes to help us develop better products and services. **Of course, all information is strictly confidential.**

1. How did you learn about us?

Advertisement Friend Catalog
 Card Deck Website Other:

2. Which of the following magazines do you subscribe to?

<input type="checkbox"/> Cabinetmaker & FDM	<input type="checkbox"/> Popular Science	<input type="checkbox"/> Wooden Boat
<input type="checkbox"/> Family Handyman	<input type="checkbox"/> Popular Woodworking	<input type="checkbox"/> Woodshop News
<input type="checkbox"/> Hand Loader	<input type="checkbox"/> Precision Shooter	<input type="checkbox"/> Woodsmith
<input type="checkbox"/> Handy	<input type="checkbox"/> Projects in Metal	<input type="checkbox"/> Woodwork
<input type="checkbox"/> Home Shop Machinist	<input type="checkbox"/> RC Modeler	<input type="checkbox"/> Woodworker West
<input type="checkbox"/> Journal of Light Cont.	<input type="checkbox"/> Rifle	<input type="checkbox"/> Woodworker's Journal
<input type="checkbox"/> Live Steam	<input type="checkbox"/> Shop Notes	<input type="checkbox"/> Other:
<input type="checkbox"/> Model Airplane News	<input type="checkbox"/> Shotgun News	
<input type="checkbox"/> Old House Journal	<input type="checkbox"/> Today's Homeowner	
<input type="checkbox"/> Popular Mechanics	<input type="checkbox"/> Wood	

3. What is your annual household income?

\$20,000-\$29,000 \$30,000-\$39,000 \$40,000-\$49,000
 \$50,000-\$59,000 \$60,000-\$69,000 \$70,000+

4. What is your age group?

20-29 30-39 40-49
 50-59 60-69 70+

5. How long have you been a woodworker/metalworker?

0-2 Years 2-8 Years 8-20 Years 20+ Years

6. How many of your machines or tools are Grizzly?

0-2 3-5 6-9 10+

7. Do you think your machine represents a good value? Yes No

8. Would you recommend Grizzly Industrial to a friend? Yes No

9. Would you allow us to use your name as a reference for Grizzly customers in your area?

Note: We never use names more than 3 times. Yes No

10. Comments: _____

CUT ALONG DOTTED LINE

FOLD ALONG DOTTED LINE



Place Stamp Here



GRIZZLY INDUSTRIAL, INC.
P.O. BOX 2069
BELLINGHAM, WA 98227-2069



FOLD ALONG DOTTED LINE

Send a Grizzly Catalog to a friend:

Name _____
Street _____
City _____ State _____ Zip _____

TAPE ALONG EDGES--PLEASE DO NOT STAPLE

WARRANTY AND RETURNS

Grizzly Industrial, Inc. warrants every product it sells for a period of **1 year** to the original purchaser from the date of purchase. This warranty does not apply to defects due directly or indirectly to misuse, abuse, negligence, accidents, repairs or alterations or lack of maintenance. This is Grizzly's sole written warranty and any and all warranties that may be implied by law, including any merchantability or fitness, for any particular purpose, are hereby limited to the duration of this written warranty. We do not warrant or represent that the merchandise complies with the provisions of any law or acts unless the manufacturer so warrants. In no event shall Grizzly's liability under this warranty exceed the purchase price paid for the product and any legal actions brought against Grizzly shall be tried in the State of Washington, County of Whatcom.

We shall in no event be liable for death, injuries to persons or property or for incidental, contingent, special, or consequential damages arising from the use of our products.

To take advantage of this warranty, contact us by mail or phone and give us all the details. We will then issue you a "Return Number," which must be clearly posted on the outside as well as the inside of the carton. We will not accept any item back without this number. Proof of purchase must accompany the merchandise.

The manufacturers reserve the right to change specifications at any time because they constantly strive to achieve better quality equipment. We make every effort to ensure that our products meet high quality and durability standards and we hope you never need to use this warranty.

Please feel free to write or call us if you have any questions about the machine or the manual.

Thank you again for your business and continued support. We hope to serve you again soon.

grizzly.com[®]
TOOL WEBSITE

Buy Direct and Save with Grizzly[®] – Trusted, Proven and a Great Value!
~Since 1983~

*Visit Our Website Today For
Current Specials!*

**ORDER
24 HOURS A DAY!
1-800-523-4777**

