

Grizzly ***Industrial, Inc.***®

MODEL G0547 **4" x 36" BELT &** **6" DISC COMBO SANDER** **OWNER'S MANUAL**

(For models manufactured since 11/15)



COPYRIGHT © NOVEMBER, 2003 BY GRIZZLY INDUSTRIAL, INC., REVISED MAY, 2016 (DN)
**WARNING: NO PORTION OF THIS MANUAL MAY BE REPRODUCED IN ANY SHAPE
OR FORM WITHOUT THE WRITTEN APPROVAL OF GRIZZLY INDUSTRIAL, INC.**

#DN18149 PRINTED IN CHINA

V2.05.16



WARNING!

This manual provides critical safety instructions on the proper setup, operation, maintenance, and service of this machine/tool. Save this document, refer to it often, and use it to instruct other operators.

Failure to read, understand and follow the instructions in this manual may result in fire or serious personal injury—including amputation, electrocution, or death.

The owner of this machine/tool is solely responsible for its safe use. This responsibility includes but is not limited to proper installation in a safe environment, personnel training and usage authorization, proper inspection and maintenance, manual availability and comprehension, application of safety devices, cutting/sanding/grinding tool integrity, and the usage of personal protective equipment.

The manufacturer will not be held liable for injury or property damage from negligence, improper training, machine modifications or misuse.



WARNING!

Some dust created by power sanding, sawing, grinding, drilling, and other construction activities contains chemicals known to the State of California to cause cancer, birth defects or other reproductive harm. Some examples of these chemicals are:

- **Lead from lead-based paints.**
- **Crystalline silica from bricks, cement and other masonry products.**
- **Arsenic and chromium from chemically-treated lumber.**

Your risk from these exposures varies, depending on how often you do this type of work. To reduce your exposure to these chemicals: Work in a well ventilated area, and work with approved safety equipment, such as those dust masks that are specially designed to filter out microscopic particles.

Table of Contents

INTRODUCTION.....	2
Contact Info.....	2
Manual Accuracy.....	2
Controls & Components.....	3
Machine Data Sheet.....	4
SECTION 1: SAFETY.....	6
Safety Instructions for Machinery.....	6
Additional Safety for Disc/Belt Sanders.....	8
SECTION 2: POWER SUPPLY.....	9
SECTION 3: SETUP.....	11
Unpacking.....	11
Needed for Setup.....	11
Inventory.....	11
Hardware Recognition Chart.....	12
Site Considerations.....	13
Bench Mounting.....	13
Assembly.....	14
Dust Collection.....	15
Test Run.....	16
SECTION 4: OPERATIONS.....	17
Disabling Switch.....	17
Disc Sanding.....	18
Belt Sanding.....	19
Changing/Replacing Sandpaper Disc.....	22
Changing/Replacing Sanding Belt.....	23
Adjusting Belt Tracking.....	23
SECTION 5: ACCESSORIES.....	24
SECTION 6: MAINTENANCE.....	26
Schedule.....	26
Cleaning Belt/Disc.....	26
Cleaning & Protecting.....	26
SECTION 7: SERVICE.....	27
Troubleshooting.....	27
Positioning Work Table.....	29
Calibrating Miter Gauge.....	29
Replacing Drive Belt.....	30
SECTION 8: WIRING.....	31
Wiring Safety Instructions.....	31
Wiring Diagram.....	32
SECTION 9: PARTS.....	33
Main Parts List.....	33
Labels & Cosmetics.....	35
WARRANTY & RETURNS.....	38

INTRODUCTION

Contact Info

We stand behind our machines! If you have questions or need help, contact us with the information below. Before contacting, make sure you get the **serial number** and **manufacture date** from the machine ID label. This will help us help you faster.

Grizzly Technical Support
1815 W. Battlefield
Springfield, MO 65807
Phone: (570) 546-9663
Email: techsupport@grizzly.com

We want your feedback on this manual. What did you like about it? Where could it be improved? Please take a few minutes to give us feedback.

Grizzly Documentation Manager
P.O. Box 2069
Bellingham, WA 98227-2069
Email: manuals@grizzly.com

Manual Accuracy

We are proud to provide a high-quality owner's manual with your new machine!

We made every effort to be exact with the instructions, specifications, drawings, and photographs in this manual. Sometimes we make mistakes, but our policy of continuous improvement also means that **sometimes the machine you receive is slightly different than shown in the manual.**

If you find this to be the case, and the difference between the manual and machine leaves you confused or unsure about something, check our website for an updated version. We post current manuals and manual updates for free on our website at www.grizzly.com.

Alternatively, you can call our Technical Support for help. Before calling, make sure you write down the **Manufacture Date** and **Serial Number** from the machine ID label (see below). This information is required for us to provide proper tech support, and it helps us determine if updated documentation is available for your machine.

		MODEL GXXXX MACHINE NAME	
SPECIFICATIONS		▲ WARNING!	
Motor:	To reduce risk of serious injury when using this machine:		
Specification:	Read manual before operation.		
Specification:	Wear safety glasses and respirator.		
Specification:	Ensure safety is correctly adjusted/setup and		
Specification:	power is connected to grounded circuit before starting.		
Weight:	4. Make sure the motor has stopped and disconnect		
	power before adjustments, maintenance, or service.		
	5. DO NOT expose to rain or dampness.		
	6. DO NOT modify this machine in any way.		
	7.		
	8.		
	9. Do not use while intoxicated or fatigued.		
	10. Maintain machine carefully to prevent accidents.		
Manufactured for Grizzly in Taiwan			

Manufacture Date

Serial Number



Controls & Components



Refer to **Figures 1–2** and the following descriptions to become familiar with the basic controls of this machine.

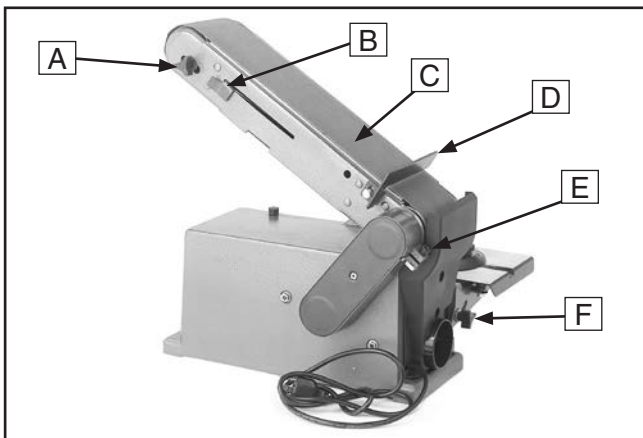

Figure 1. Back controls.

- A. Tracking Knob:** Used to adjust alignment of sanding belt to sanding bed.
- B. Belt Tensioning Lever:** When pressed in, provides tension to sanding belt during use. When pulled out, releases tension for changing/replacing belt.
- C. Sanding Belt:** Used for sanding with grain along length of workpiece, and for sanding inside curves.

- D. Backstop:** Prevents workpiece from being thrown by rotation of sanding belt.
- E. Bed Angle Release Screw:** Allows the sanding bed to raise or lower 0°–90° for both horizontal and vertical sanding.
- F. Table Angle Knob:** Tightens to secure work table at desired angle.

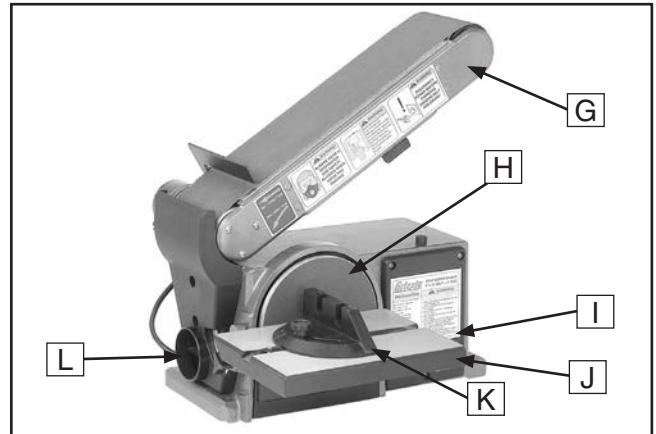

Figure 2. Front controls.

- G. Sanding Bed:** The surface around which the sanding belt rotates; tilts from 0°–90°.
- H. Sanding Disc:** Used for performing angle and miter sanding operations on work table.
- I. ON/OFF Switch:** Turns the machine ON and OFF when disabling key is inserted.
- J. Disc Sanding Table:** Supports workpiece during angle, miter, and compound miter sanding.
- K. Miter Gauge:** Supports workpiece for miter sanding. Adjustable from 60° left–60° right.
- L. Dust Port:** Connects to dust collection system (not included).

! CAUTION
For Your Own Safety Read Instruction Manual Before Operating the Sander

- a) Wear eye and ear protection.
- b) Support workpiece on worktable.
- c) Maintain the smallest gap possible between worktable and sandpaper.
- d) Avoid kickback by sanding in accordance with directional arrows.





MACHINE DATA SHEET

Customer Service #: (570) 546-9663 · To Order Call: (800) 523-4777 · Fax #: (800) 438-5901

MODEL G0547 COMBO SANDER 4" X 36" BELT 6" DISC

Product Dimensions:

Weight..... 34 lbs.
Width (side-to-side) x Depth (front-to-back) x Height..... 17-1/2 x 14-3/8 x 23-3/4 in.
Footprint (Length x Width)..... 14-5/8 x 6-5/8 in.

Shipping Dimensions:

Type..... Cardboard Box
Content..... Machine
Weight..... 39 lbs.
Length x Width x Height..... 12 x 22 x 11 in.

Electrical:

Power Requirement..... 110V, Single-Phase, 60 Hz
Prewired Voltage..... 110V
Full-Load Current Rating..... 5A
Minimum Circuit Size..... 15A
Connection Type..... Cord & Plug
Power Cord Included..... Yes
Power Cord Length..... 4 ft.
Power Cord Gauge..... 18 AWG
Plug Included..... Yes
Included Plug Type..... 5-15
Switch Type..... Toggle Safety Switch w/Removable Key

Motors:

Main

Type..... ODP Permanent-Split Capacitor
Horsepower..... 1/3 HP
Phase..... Single-Phase
Amps..... 5A
Speed..... 3450 RPM
Power Transfer Belt Drive
Bearings..... Sealed & Permanently Lubricated

Main Specifications:

Belt Sander Info

Sanding Belt Width..... 4 in.
Sanding Belt Length..... 36 in.
Sanding Belt Speed..... 1970 FPM
Sanding Belt Tilt..... 90 deg.
Max Height of Belt in Vertical Position..... 23-3/4 in.
Belt Tension Release Type..... Quick Release
Platen Type..... Steel
Platen Length..... 12-1/4 in.
Platen Width..... 4-3/8 in.



Disc Sander Info

Disc Diameter..... 6 in.
 Disc Speed..... 3450 RPM
 Disc Sandpaper Backing Type..... PSA
 Table Length..... 6-1/4 in.
 Table Width..... 8-7/8 in.
 Table Tilt..... Left 0, Right 45 deg.
 Table-to-Floor Height..... 4-3/4 in.

Construction Materials

Base..... Cast Iron
 Table..... Die-Cast Aluminum
 Frame..... Cast Iron
 Disc..... Aluminum
 Miter Gauge..... Plastic/Steel Bar
 Paint Type/Finish..... Powder Coated

Other Related Info

Miter Gauge Slot Width..... 5/8 in.
 Miter Gauge Slot Height..... 1/4 in.
 Number of Dust Ports..... 1
 Dust Port Size..... 2-1/2 in.

Other Specifications:

Country of Origin China
 Warranty 1 Year
 Approximate Assembly & Setup Time 30 Minutes
 Serial Number Location ID Label
 ISO 9001 Factory No
 Certified by a Nationally Recognized Testing Laboratory (NRTL) No

Features:

- Adjustable Miter Gauge
- Single Knob Tracking Adjustment
- Built In Dust Port
- Cast-Iron Construction



SECTION 1: SAFETY

For Your Own Safety, Read Instruction Manual Before Operating This Machine

The purpose of safety symbols is to attract your attention to possible hazardous conditions. This manual uses a series of symbols and signal words intended to convey the level of importance of the safety messages. The progression of symbols is described below. Remember that safety messages by themselves do not eliminate danger and are not a substitute for proper accident prevention measures. Always use common sense and good judgment.

 **DANGER** Indicates an imminently hazardous situation which, if not avoided, **WILL** result in death or serious injury.

 **WARNING** Indicates a potentially hazardous situation which, if not avoided, **COULD** result in death or serious injury.

 **CAUTION** Indicates a potentially hazardous situation which, if not avoided, **MAY** result in minor or moderate injury. It may also be used to alert against unsafe practices.

NOTICE This symbol is used to alert the user to useful information about proper operation of the machine.

Safety Instructions for Machinery

WARNING

OWNER'S MANUAL. Read and understand this owner's manual **BEFORE** using machine.

TRAINED OPERATORS ONLY. Untrained operators have a higher risk of being hurt or killed. Only allow trained/supervised people to use this machine. When machine is not being used, disconnect power, remove switch keys, or lock-out machine to prevent unauthorized use—especially around children. Make your workshop kid proof!

DANGEROUS ENVIRONMENTS. Do not use machinery in areas that are wet, cluttered, or have poor lighting. Operating machinery in these areas greatly increases the risk of accidents and injury.

MENTAL ALERTNESS REQUIRED. Full mental alertness is required for safe operation of machinery. Never operate under the influence of drugs or alcohol, when tired, or when distracted.

ELECTRICAL EQUIPMENT INJURY RISKS. You can be shocked, burned, or killed by touching live electrical components or improperly grounded machinery. To reduce this risk, only allow qualified service personnel to do electrical installation or repair work, and always disconnect power before accessing or exposing electrical equipment.

DISCONNECT POWER FIRST. Always disconnect machine from power supply **BEFORE** making adjustments, changing tooling, or servicing machine. This prevents an injury risk from unintended startup or contact with live electrical components.

EYE PROTECTION. Always wear ANSI-approved safety glasses or a face shield when operating or observing machinery to reduce the risk of eye injury or blindness from flying particles. Everyday eyeglasses are **NOT** approved safety glasses.



WARNING

WEARING PROPER APPAREL. Do not wear clothing, apparel or jewelry that can become entangled in moving parts. Always tie back or cover long hair. Wear non-slip footwear to reduce risk of slipping and losing control or accidentally contacting cutting tool or moving parts.

HAZARDOUS DUST. Dust created by machinery operations may cause cancer, birth defects, or long-term respiratory damage. Be aware of dust hazards associated with each workpiece material. Always wear a NIOSH-approved respirator to reduce your risk.

HEARING PROTECTION. Always wear hearing protection when operating or observing loud machinery. Extended exposure to this noise without hearing protection can cause permanent hearing loss.

REMOVE ADJUSTING TOOLS. Tools left on machinery can become dangerous projectiles upon startup. Never leave chuck keys, wrenches, or any other tools on machine. Always verify removal before starting!

USE CORRECT TOOL FOR THE JOB. Only use this tool for its intended purpose—do not force it or an attachment to do a job for which it was not designed. Never make unapproved modifications—modifying tool or using it differently than intended may result in malfunction or mechanical failure that can lead to personal injury or death!

AWKWARD POSITIONS. Keep proper footing and balance at all times when operating machine. Do not overreach! Avoid awkward hand positions that make workpiece control difficult or increase the risk of accidental injury.

CHILDREN & BYSTANDERS. Keep children and bystanders at a safe distance from the work area. Stop using machine if they become a distraction.

GUARDS & COVERS. Guards and covers reduce accidental contact with moving parts or flying debris. Make sure they are properly installed, undamaged, and working correctly **BEFORE** operating machine.

FORCING MACHINERY. Do not force machine. It will do the job safer and better at the rate for which it was designed.

NEVER STAND ON MACHINE. Serious injury may occur if machine is tipped or if the cutting tool is unintentionally contacted.

STABLE MACHINE. Unexpected movement during operation greatly increases risk of injury or loss of control. Before starting, verify machine is stable and mobile base (if used) is locked.

USE RECOMMENDED ACCESSORIES. Consult this owner's manual or the manufacturer for recommended accessories. Using improper accessories will increase the risk of serious injury.

UNATTENDED OPERATION. To reduce the risk of accidental injury, turn machine **OFF** and ensure all moving parts completely stop before walking away. Never leave machine running while unattended.

MAINTAIN WITH CARE. Follow all maintenance instructions and lubrication schedules to keep machine in good working condition. A machine that is improperly maintained could malfunction, leading to serious personal injury or death.

DAMAGED PARTS. Regularly inspect machine for damaged, loose, or mis-adjusted parts—or any condition that could affect safe operation. Immediately repair/replace **BEFORE** operating machine. For your own safety, **DO NOT** operate machine with damaged parts!

MAINTAIN POWER CORDS. When disconnecting cord-connected machines from power, grab and pull the plug—**NOT** the cord. Pulling the cord may damage the wires inside. Do not handle cord/plug with wet hands. Avoid cord damage by keeping it away from heated surfaces, high traffic areas, harsh chemicals, and wet/damp locations.

EXPERIENCING DIFFICULTIES. If at any time you experience difficulties performing the intended operation, stop using the machine! Contact our Technical Support at (570) 546-9663.



Additional Safety for Disc/Belt Sanders

WARNING

Serious injury can occur from fingers or hands contacting sandpaper, or from fingers, clothes, or hair getting entangled in sanding disc or belt. Workpieces thrown by sander can strike nearby operators. Long-term respiratory damage can occur from using sander without proper use of a respirator and an adequate dust collection system. To minimize risk of getting hurt or killed, anyone operating machine **MUST** completely heed hazards and warnings below.

DISC DIRECTION. Only sand on downward-moving left side of sanding disc. Sanding on upward-moving right side of sanding disc forces operator to rely only on hands (rather than table) for support, which increases risk of workpiece “kick-out” and impact/abrasion injuries.

HAND PLACEMENT. Rotating sandpaper can remove a large amount of flesh in a few seconds. Always keep hands away from sandpaper during operation. Never touch moving sandpaper on purpose. Use a brush to clean table of sawdust and chips.

FEEDING WORKPIECE. Forcefully jamming workpiece into sanding surface could cause workpiece to be aggressively grabbed and pull your hands into sanding surface. Firmly grasp workpiece in both hands and ease it into sandpaper using light pressure.

MINIMUM STOCK DIMENSION. Small workpieces can be aggressively pulled from your hands. Always use a jig or other holding device when sanding small workpieces, and keep hands and fingers at least 2” away from sanding surface.

AVOIDING ENTANGLEMENT. Becoming entangled in moving parts of this machine can cause pinching and crushing injuries. To avoid these hazards, DO NOT wear loose clothing, gloves, or jewelry, and tie back long hair. Keep all guards in place and secure.

IN-RUNNING NIP POINTS. The gap between moving sandpaper and fixed table/support creates a pinch point for fingers or workpieces; the larger this gap is, the greater risk of fingers or workpieces getting caught in it. Minimize this risk by adjusting table no more than $\frac{1}{16}$ ” away from sandpaper.

WORKPIECE SUPPORT. Workpiece kickback can occur with violent force if workpiece is not properly supported during operation. Always sand with workpiece firmly against table or another support device.

WORKPIECE INSPECTION. Nails, staples, knots, or other imperfections in workpiece can be dislodged and thrown from sander at high rate of speed into operator or bystanders, or cause damage to sandpaper or sander. Never try to sand stock that has embedded foreign objects or questionable imperfections.

SANDPAPER CONDITION. Worn or damaged sandpaper not only produces poor sanding results, but could fly apart, aggressively grab workpiece, and throw debris at the operator. Always inspect sandpaper before operation and replace if worn or damaged.

WORKPIECE INTEGRITY. Only sand solid workpieces that can withstand power sanding forces. Make sure shape of workpiece is properly supported on table; avoid sanding workpieces without flat bottom surfaces unless some type of jig is used to maintain support and control when sanding force is applied.

SANDING DUST. Sanding creates large amounts of dust and flying chips that can lead to eye injury or respiratory illness. Reduce risk of these hazards by wearing approved eye and respiratory protection when using sander.

DUST COLLECTION. Never operate without adequate dust collection system in place and running. Proper dust collection reduces dust in work area, which decreases risk of long-term respiratory damage, but it is not a substitute for using a respirator.



SECTION 2: POWER SUPPLY

Availability

Before installing the machine, consider the availability and proximity of the required power supply circuit. If an existing circuit does not meet the requirements for this machine, a new circuit must be installed. To minimize the risk of electrocution, fire, or equipment damage, installation work and electrical wiring must be done by an electrician or qualified service personnel in accordance with all applicable codes and standards.

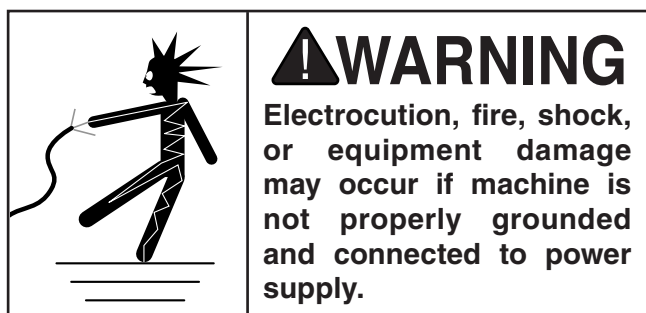

Full-Load Current Rating

The full-load current rating is the amperage a machine draws at 100% of the rated output power. On machines with multiple motors, this is the amperage drawn by the largest motor or sum of all motors and electrical devices that might operate at one time during normal operations.

Full-Load Current Rating at 110V..... 5 Amps

The full-load current is not the maximum amount of amps that the machine will draw. If the machine is overloaded, it will draw additional amps beyond the full-load rating.

If the machine is overloaded for a sufficient length of time, damage, overheating, or fire may result—especially if connected to an undersized circuit. To reduce the risk of these hazards, avoid overloading the machine during operation and make sure it is connected to a power supply circuit that meets the specified circuit requirements.

! WARNING

Serious injury could occur if you connect machine to power before completing setup process. DO NOT connect to power until instructed later in this manual.

110V Circuit Requirements

This machine is prewired to operate on a power supply circuit that has a verified ground and meets the following requirements:

Nominal Voltage 110V
Cycle 60 Hz
Phase Single-Phase
Power Supply Circuit 15 Amps

A power supply circuit includes all electrical equipment between the breaker box or fuse panel in the building and the machine. The power supply circuit used for this machine must be sized to safely handle the full-load current drawn from the machine for an extended period of time. (If this machine is connected to a circuit protected by fuses, use a time delay fuse marked D.)

! CAUTION

For your own safety and protection of property, consult an electrician if you are unsure about wiring practices or electrical codes in your area.

Note: *Circuit requirements in this manual apply to a dedicated circuit—where only one machine will be running on the circuit at a time. If machine will be connected to a shared circuit where multiple machines may be running at the same time, consult an electrician or qualified service personnel to ensure circuit is properly sized for safe operation.*



Grounding & Plug Requirements

This machine **MUST** be grounded. In the event of certain malfunctions or breakdowns, grounding reduces the risk of electric shock by providing a path of least resistance for electric current.

This machine is equipped with a power cord that has an equipment-grounding wire and a grounding plug. Only insert plug into a matching receptacle (outlet) that is properly installed and grounded in accordance with all local codes and ordinances. **DO NOT** modify the provided plug!

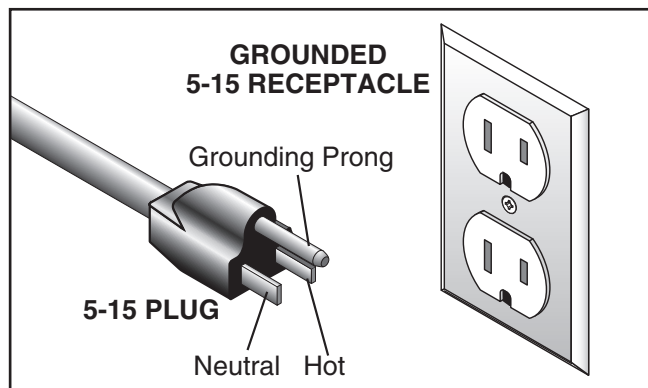

Figure 3. Typical 5-15 plug and receptacle.

⚠ CAUTION

SHOCK HAZARD!

Two-prong outlets do not meet the grounding requirements for this machine. Do not modify or use an adapter on the plug provided—if it will not fit the outlet, have a qualified electrician install the proper outlet with a verified ground.

Improper connection of the equipment-grounding wire can result in a risk of electric shock. The wire with green insulation (with or without yellow stripes) is the equipment-grounding wire. If repair or replacement of the power cord or plug is necessary, do not connect the equipment-grounding wire to a live (current carrying) terminal.

Check with a qualified electrician or service personnel if you do not understand these grounding requirements, or if you are in doubt about whether the tool is properly grounded. If you ever notice that a cord or plug is damaged or worn, disconnect it from power, and immediately replace it with a new one.

Extension Cords

We do not recommend using an extension cord with this machine. If you must use an extension cord, only use it if absolutely necessary and only on a temporary basis.

Extension cords cause voltage drop, which can damage electrical components and shorten motor life. Voltage drop increases as the extension cord size gets longer and the gauge size gets smaller (higher gauge numbers indicate smaller sizes).

Any extension cord used with this machine must be in good condition and contain a ground wire and matching plug/receptacle. Additionally, it must meet the following size requirements:

Minimum Gauge Size 16 AWG
Maximum Length (Shorter is Better).....50 ft.



SECTION 3: SETUP

Unpacking

This machine was carefully packaged for safe transport. When unpacking, separate all enclosed items from packaging materials and inspect them for shipping damage. ***If items are damaged, please call us immediately at (570) 546-9663.***

IMPORTANT: Save all packaging materials until you are completely satisfied with the machine and have resolved any issues between Grizzly or the shipping agent. ***You MUST have the original packaging to file a freight claim. It is also extremely helpful if you need to return your machine later.***



Needed for Setup

The following are needed to complete the setup process, but are not included with your machine.

Description	Qty
• Safety Glasses	1 Pair
• Screwdriver Phillips #2	1
• Hex Wrench 6mm.....	1
• Dust Collection System	1
• Dust Hose 2½"	1
• Hose Clamps 2½"	2
• Machinist Square.....	1
• Open-End Wrench 10mm.....	1

Inventory

The following is a list of items shipped with your machine. Before beginning setup, lay these items out and inventory them.

If any non-proprietary parts are missing (e.g. a nut or a washer), we will gladly replace them; or for the sake of expediency, replacements can be obtained at your local hardware store.

DESCRIPTION	Qty
A. Disc Sanding Table	1
B. Miter Gauge.....	1
C. Hardware Bag	
—Lock Knob M6-1 x 30	1
—Flat Washers 6mm	5
—Lock Washers 6mm.....	4
—Hex Bolts M6-1 x 14	4
—Tap Screws M4 x 8	2
—Angle Measurement Label.....	1
D. Disc Guard	1
E. Backstop.....	1
F. Table Support.....	1
G. Sanding Disc	1

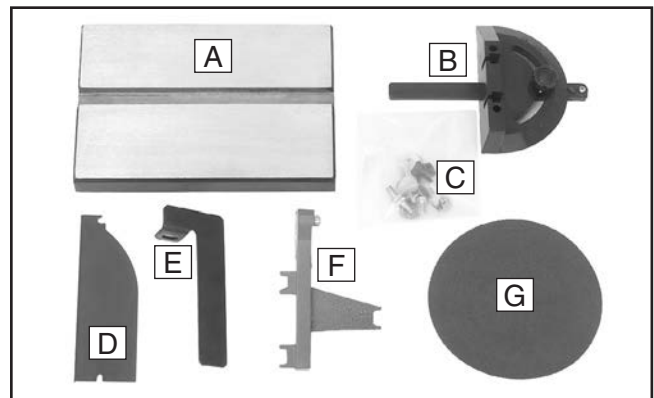

Figure 4. Model G0547 inventory.

NOTICE







If you cannot find an item on this list, carefully check around/inside the machine and packaging materials. Often, these items get lost in packaging materials while unpacking or they are pre-installed at the factory.









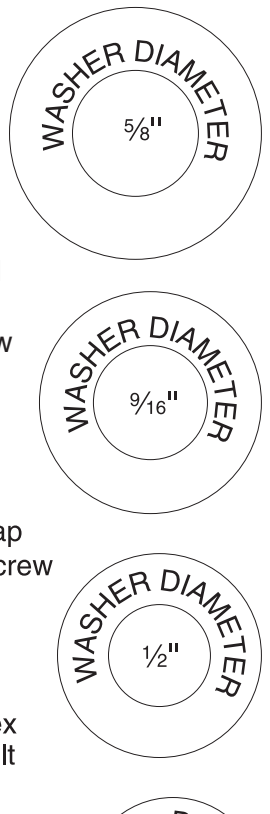
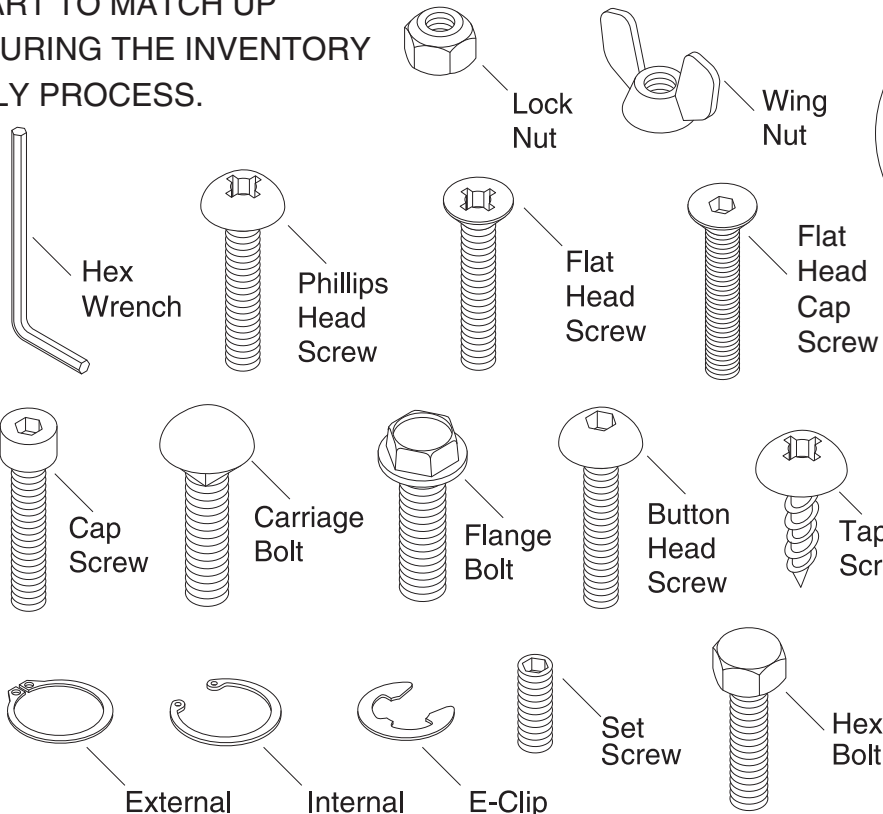

Hardware Recognition Chart

USE THIS CHART TO MATCH UP
HARDWARE DURING THE INVENTORY
AND ASSEMBLY PROCESS.

MEASURE BOLT DIAMETER BY PLACING INSIDE CIRCLE

-  #10
-  1/4"
-  5/16"
-  3/8"
-  7/16"
-  1/2"



-  4mm
-  5mm
-  6mm
-  8mm
-  10mm
-  12mm
-  16mm

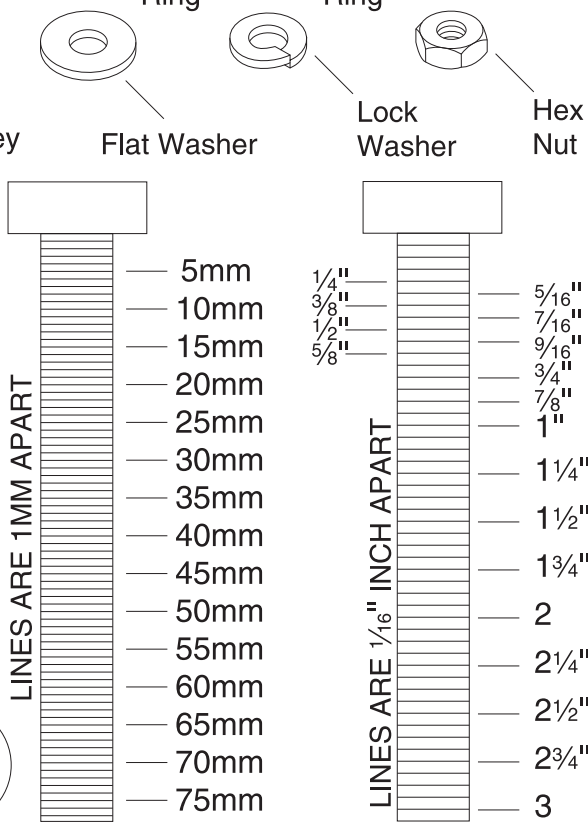

WASHERS ARE MEASURED BY THE INSIDE DIAMETER

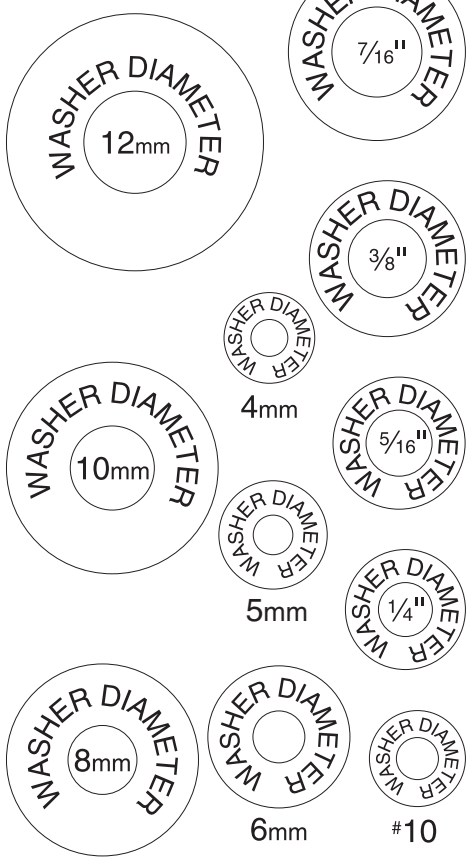

Site Considerations

Workbench Load

Refer to the **Machine Data Sheet** for the weight and footprint specifications of your machine. Some workbenches may require additional reinforcement to support the weight of the machine and workpiece materials.

Placement Location

Consider anticipated workpiece sizes and additional space needed for auxiliary stands, work tables, or other machinery when establishing a location for this machine in the shop. Below is the minimum amount of space needed for the machine.

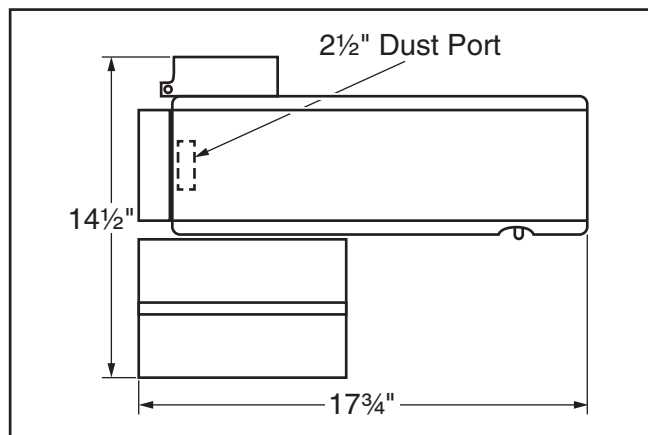

Figure 5. Minimum working clearances.

	<p>⚠ CAUTION</p> <p>Children and visitors may be seriously injured if unsupervised around this machine. Lock entrances to the shop or disable start switch or power connection to prevent unsupervised use.</p>
--	--

Bench Mounting

Number of Mounting Holes 2
Diameter of Mounting Hardware Needed .. 1/4"

The base of this machine has mounting holes that allow it to be fastened to a workbench or other mounting surface to prevent it from moving during operation and causing accidental injury or damage.

The strongest mounting option is a "Through Mount" (see example below) where holes are drilled all the way through the workbench—and hex bolts, washers, and hex nuts are used to secure the machine in place.

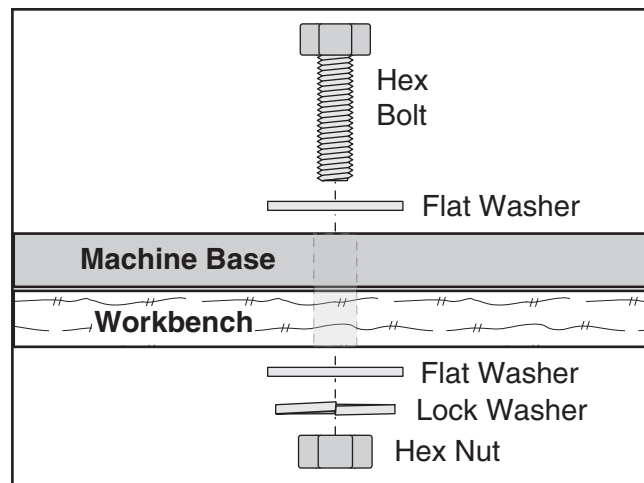

Figure 6. "Through Mount" setup.

Another option is a "direct mount" (see example below) where the machine is secured directly to the workbench with lag screws and washers.

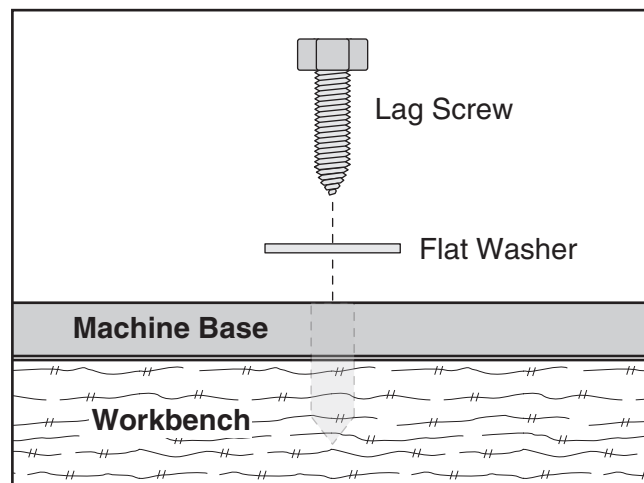

Figure 7. "Direct Mount" setup.



Assembly

The machine must be fully assembled before it can be operated. Before beginning the assembly process, refer to **Needed for Setup** and gather all listed items. To ensure the assembly process goes smoothly, first clean any parts that are covered or coated in heavy-duty rust preventative (if applicable).

To assemble sander:

1. Attach sandpaper disc to aluminium disc (see **Attaching Sandpaper Disc on Page 22**).
2. Mount disc cover to holes in sander body near bottom of aluminium disc using (2) M4 x 8 tap screws, as shown in **Figure 8**.

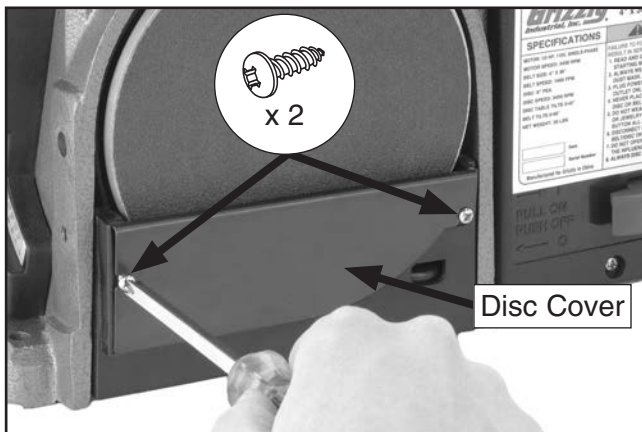

Figure 8. Installing disc cover.

3. Lay disc sanding table upside down and align table support with holes in table (see **Figure 9**).

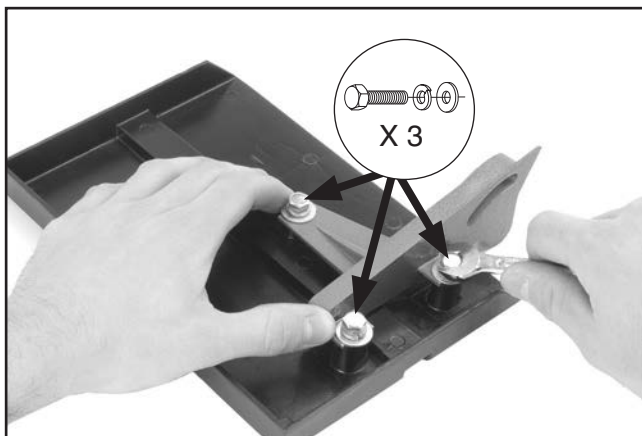

Figure 9. Attaching table support to disc table.

4. Use (3) M6-1 x 14 hex bolts, (3) 6mm lock washers, and (3) 6mm flat washers to attach table support to table (see **Figure 9**).
5. Insert work table index pin into upper hole on sander base (see **Figure 10**).
6. Insert table lock knob with flat washer (see **Figure 10**) through slot in work table and into threaded hole in sander body.
7. Set work table at desired angle and tighten table lock knob (see **Figure 10**).

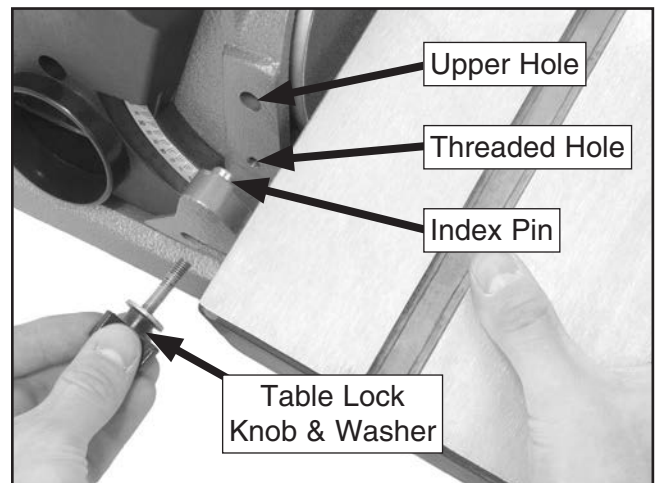

Figure 10. Installing work table.

8. Use M6-1 x 14 hex bolt with 6mm flat washer and 6mm lock washer to attach backstop to sander body (see **Figure 11**).
9. Square backstop as shown in **Figure 11**, and tighten hex bolt, leaving $\frac{1}{8}$ " between backstop and belt.

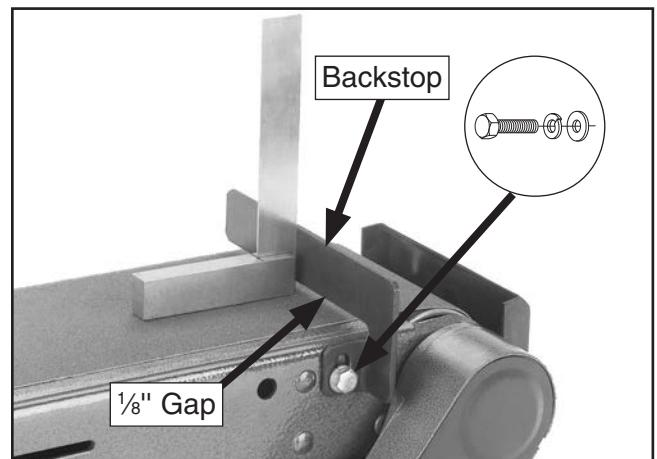

Figure 11. Squaring backstop.



10. Align work table for proper spacing between disc and table (Refer to **Page 29** for instructions).
11. Using a try square or machinist's square, set one edge on table surface and the other against disc face, as shown in **Figure 12**.

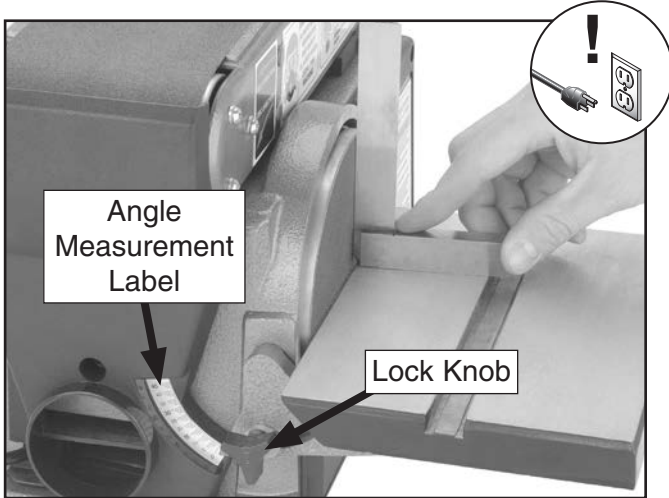

Figure 12. Squaring disc table.

12. Loosen lock knob and adjust table angle until there is no gap between disc face and square.
13. Tighten lock knob while holding table perpendicular.
14. Place angle measurement label on base so angle indicator points to 0°.

Dust Collection

! CAUTION

This machine creates a lot of wood chips/dust during operation. Breathing airborne dust on a regular basis can result in permanent respiratory illness. Reduce your risk by wearing a respirator and capturing the dust with a dust collection system.

Recommended CFM at Dust Port: 250 CFM
 Do not confuse this CFM recommendation with the rating of the dust collector. To determine the CFM at the dust port, you must consider these variables: (1) CFM rating of the dust collector, (2) hose type and length between the dust collector and the machine, (3) number of branches or wyes, and (4) amount of other open lines throughout the system. Explaining how to calculate these variables is beyond the scope of this manual. Consult an expert or purchase a good dust collection "how-to" book.

To connect dust collection hose:

1. Fit 2½" dust hose over dust port, as shown in **Figure 13**, and secure in place with hose clamp.

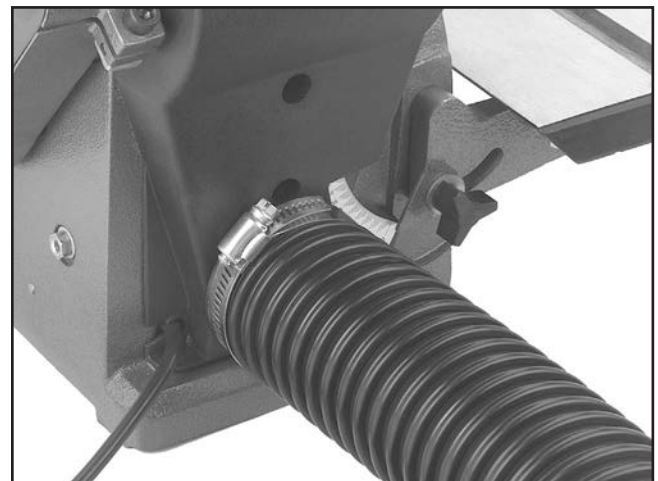

Figure 13. Dust hose attached to dust port.

2. Tug hose to make sure it does not come off.

Note: A tight fit is necessary for proper performance.



Test Run

Once assembly is complete, test run the machine to ensure it is properly connected to power and safety components are functioning correctly.

If you find an unusual problem during the test run, immediately stop the machine, disconnect it from power, and fix the problem **BEFORE** operating the machine again. The **Troubleshooting** table in the **SERVICE** section of this manual can help.

WARNING

Serious injury or death can result from using this machine BEFORE understanding its controls and related safety information. DO NOT operate, or allow others to operate, machine until the information is understood.

WARNING

DO NOT start machine until all preceding setup instructions have been performed. Operating an improperly set up machine may result in malfunction or unexpected results that can lead to serious injury, death, or machine/property damage.

To test run the machine:

1. Clear all setup tools away from machine.
2. Connect machine to power supply with switch down in the **OFF** position.
3. Turn machine **ON** by pulling switch away from base, verify motor operation, and then turn machine **OFF**.

The motor should run smoothly and without unusual problems or noises.

4. Remove switch disabling key, as shown in **Figure 14**.

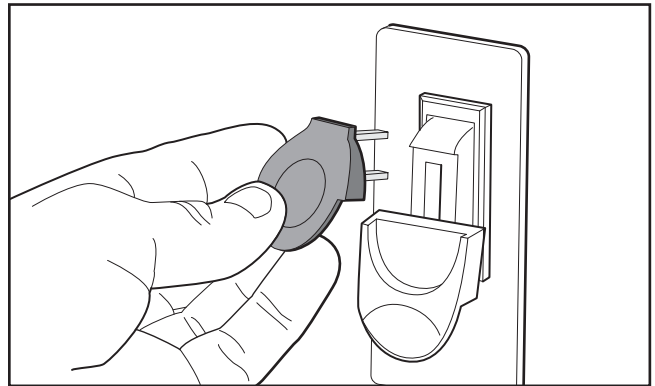
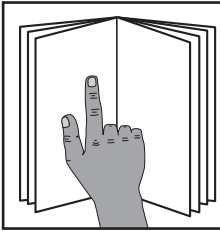

Figure 14. Removing switch key from paddle switch.

5. Try to start machine with paddle switch. The machine should not start.
 - If the machine *does not* start, the switch disabling feature is working as designed.
 - If the machine *does start*, immediately stop the machine. The switch disabling feature is not working correctly. This safety feature must work properly before proceeding with regular operations. Call Tech Support for help.
6. Remove the locking key when the machine is not in use and store the key in a safe place.



SECTION 4: OPERATIONS



!WARNING

To reduce your risk of serious injury, read this entire manual **BEFORE** using machine.

!WARNING

To reduce risk of eye injury from flying chips or lung damage from breathing dust, always wear safety glasses and a respirator when operating this machine.

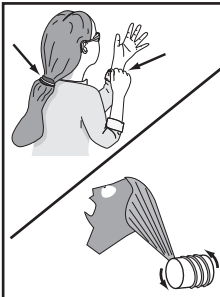
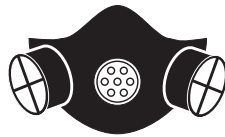

!WARNING

Keep hair, clothing, and jewelry away from moving parts at all times. Entanglement can result in death, amputation, or severe crushing injuries!

NOTICE

If you are not experienced with this type of machine, **WE STRONGLY RECOMMEND** that you seek additional training outside of this manual. Read books/magazines or get formal training before beginning any projects. Regardless of the content in this section, Grizzly Industrial will not be held liable for accidents caused by lack of training.

Disabling Switch

The switch can be disabled by removing the key, as shown below. Disabling the switch in this manner can prevent unauthorized operation of the machine, which is important if it is not kept inside an access-restricted building or in a location where children may be present.

IMPORTANT: Disabling the switch only restricts its function. It is not a substitute for disconnecting machine from power when adjusting or servicing.

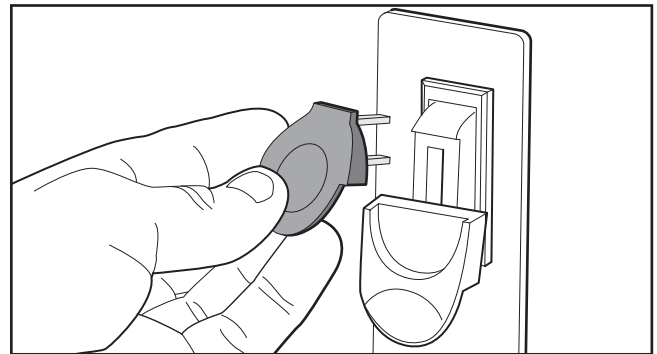

Figure 15. Disabling switch by removing key.

!WARNING

Children or untrained people can be seriously injured by this machine. This risk increases with unsupervised operation. To help prevent unsupervised operation, always disable switch before leaving machine unattended. Make sure to place key in a well-hidden or secure location!



Disc Sanding

⚠ CAUTION

Only sand workpiece on side of sanding disc that is rotating down toward work table. This will keep workpiece from flying out of your hands due to rotational force of disc.

Setting Work Table Angle

Set the work table angle relative to the sanding disc. The angle can be set using the angle scale on the sander body, or for greater accuracy, a protractor or machinist's square can be used.

Tool Needed	Qty
Machinist's Square	1

To set work table angle:

1. DISCONNECT MACHINE FROM POWER!
2. Loosen angle adjustment knob, and position work table so pointer on end of work table support aligns with desired angle on angle scale (see **Figure 16**).

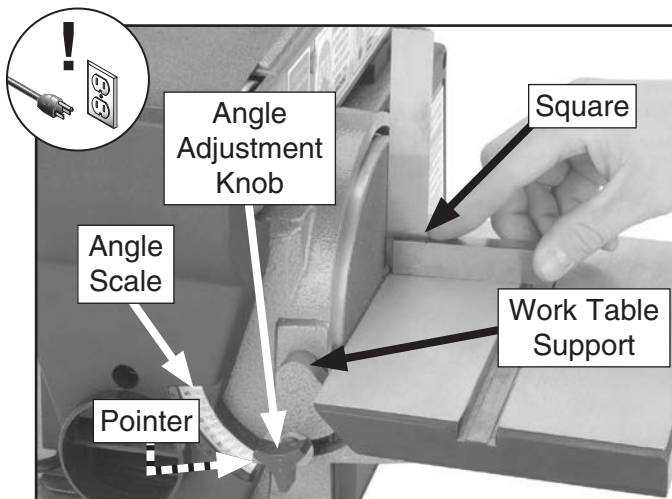

Figure 16. Setting work table angle.

3. Retighten angle adjustment knob.

Adjusting Miter Gauge Angle

1. Place miter gauge in slot in work table, then loosen miter gauge lock knob shown in **Figure 17**.

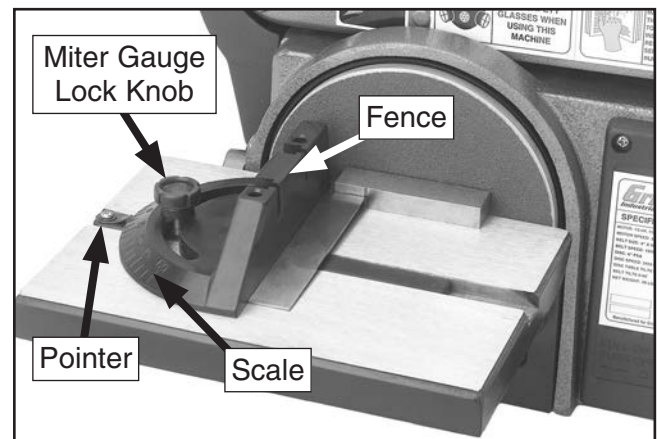

Figure 17. Setting miter gauge angle.

2. Rotate fence until pointer indicates desired angle on scale, then retighten lock knob.

Note: For instructions on calibrating your miter gauge, see **Calibrating Miter Gauge** on **Page 29**.

Performing Disc Sanding Operations

For disc sanding straight lines, always brace your workpiece against the miter gauge for maximum stability. We do not recommend disc sanding without a miter gauge unless absolutely necessary, as with sanding outside curves. For more information, see **Sanding Outside Curves** on **Page 19**.

To perform disc sanding operations:

1. Set work table and miter gauge angles, as described on this page.
2. Turn machine **ON**.



Figure 18. Disc sanding.



- Place workpiece on work table and brace it against miter gauge (see **Figure 19**).



Figure 19. Angle disc sanding.

- While keeping workpiece snug against miter gauge fence, gently feed it into downward spinning half of sanding disc.
- Use light pressure, and slowly move workpiece side to side along downward spinning half of sanding disc to prevent burning workpiece and excessive loading of sandpaper.

Sanding Outside Curves

The Model G0547 disc sander can be used to sand convex (outside) curves. Since the miter gauge is not used for this operation, use both hands to hold the workpiece.

To sand outside curves:

- Remove miter gauge.
- Turn machine **ON**.
- Place workpiece on work table, and gently feed it into downward spinning half of sanding disc.
- Using light pressure, slowly move workpiece side to side along downward spinning half of sanding disc to prevent burning workpiece and excessive loading of sandpaper.

Belt Sanding

The Model G0547 belt sander bed tilts from 0°–90°, allowing for both horizontal and vertical belt sanding.

The horizontal position is generally used for sanding with the grain along the length of a workpiece, and for sanding inside curves.

The vertical position is best used with the work table attached to the bed, for miter sanding and sanding outside curves.

Tool Needed	Qty
6mm Hex Wrench.....	1

Adjusting Sanding Bed Angle

- DISCONNECT MACHINE FROM POWER!
- Loosen bed angle release screw, as shown in **Figure 20**.

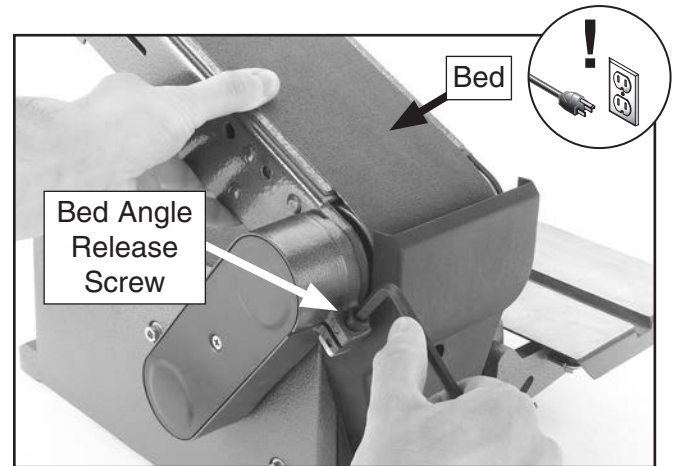

Figure 20. Bed angle adjustment.

- Raise or lower bed to desired angle, then retighten bed angle release screw.



Horizontal Sanding

1. Adjust bed to horizontal position, as described in **Adjusting Sanding Bed Angle** on **Page 19**.
2. Turn machine **ON** and allow sander to reach full speed.
3. Place workpiece on surface of sanding belt, allowing it to rest against backstop. Hold workpiece firmly, and keep fingers away from sanding surface (see **Figure 21**).

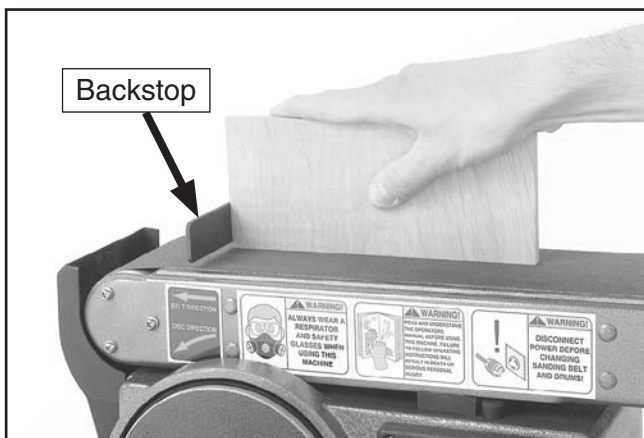

Figure 21. Horizontal belt sanding.

4. Using light pressure, use both hands to move workpiece back and forth across surface of sanding belt to prevent burning workpiece, excessive loading of belt, and uneven belt wear.

Inside Curve Sanding

The sanding belt can be used to sand concave (inside) curves, using the idler drum end of the sanding belt.

To sand inside curves:

1. Turn machine **ON** and allow sander to reach full speed.
2. Hold workpiece against idler drum end of sanding belt, as shown in **Figure 22**, and with light pressure, move workpiece slowly back and forth across surface of sanding belt.



Figure 22. Sanding an inside curve.



Vertical Sanding

Vertical sanding is best performed with the work table attached to the sanding bed, for operations similar to disc sanding. With more surface area than the sanding disc, the sanding belt can sand more aggressively.

To mount work table to sanding bed:

1. DISCONNECT MACHINE FROM POWER!
2. Remove hex bolt, flat washer, lock washer, and backstop from sanding bed (see **Figure 23**).
3. Loosen work table lock knob (see **Figure 23**) and remove lock knob, flat washer, and work table from sanding disc.

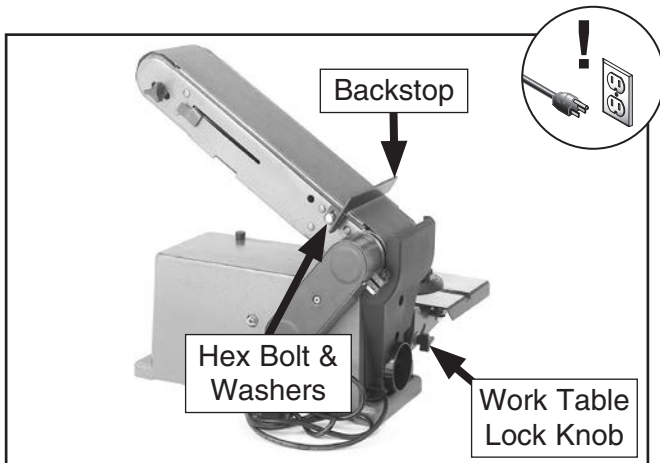

Figure 23. Backstop removal.

4. Adjust sanding bed to vertical position (see **Adjusting Sanding Bed Angle** on **Page 19**).

5. Insert index pin of work table into mounting hole in sanding bed (see **Figure 24**).
6. Insert table lock knob with flat washer through slot in work table, and into threaded hole in sander body (see **Figure 24**).

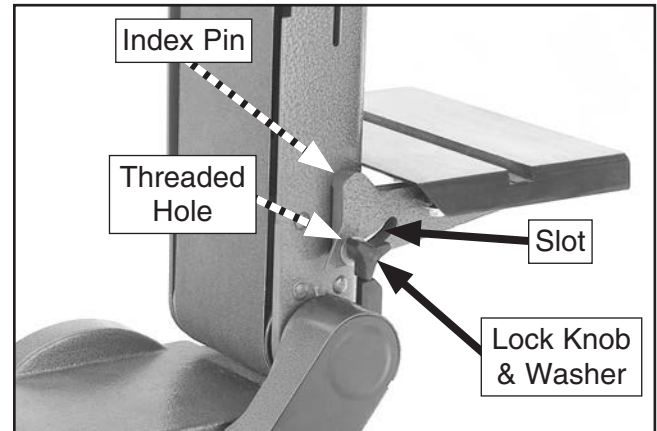

Figure 24. Installing work table on sanding bed.

7. Set desired work table angle (see **Setting Work Table Angle** on **Page 18**), and tighten table lock knob.



Changing/Replacing Sandpaper Disc

The Model G0547 Disc/Belt Sander accepts 6" diameter cloth or paper-backed pressure sensitive adhesive (PSA) sandpaper discs. These are available in a variety of grits through the Grizzly catalog. See **Accessories** on **Page 24** for ordering information.

The PSA sandpaper discs stick directly to the surface of the aluminium disc.

Removing Sandpaper Disc

1. DISCONNECT MACHINE FROM POWER!
2. Remove work table and disc cover (see **Figure 25**).

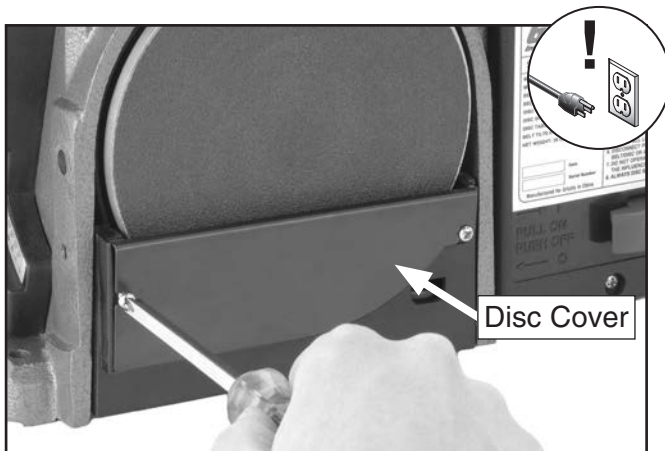

Figure 25. Removing disc cover.

3. Remove old sandpaper disc from aluminium disc.

Attaching Sandpaper Disc

Before attaching new sandpaper, make sure all dust, grit, and adhesive from old sandpaper is cleaned off aluminium disc. This will ensure a good bond between sandpaper and disc.

To attach sandpaper disc:

1. Peel back protective layer from one-half of new sandpaper disc and fold it against remaining half.
2. Center sticky half of sandpaper disc on upper half of aluminium disc and press sandpaper disc onto surface (see **Figure 26**).

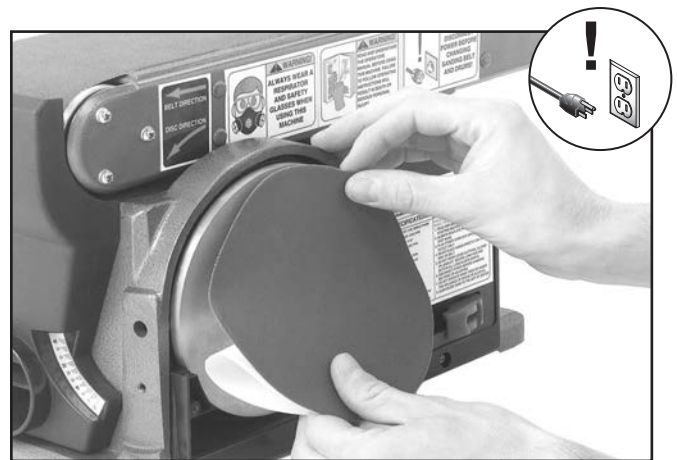

Figure 26. Installing sanding disc.

3. Remove remaining half of protective layer from sandpaper disc, then press remaining portion of sandpaper disc onto aluminium disc.
4. Rotate disc by hand and check to make sure sandpaper is firmly attached to disc without any bumps or wrinkles.
5. Re-install disc cover and work table.
6. Check work table alignment and adjust if necessary (see **Positioning Work Table** on **Page 29**).



Changing/Replacing Sanding Belt

This sander requires a 36" x 6" sanding belt. When installing, it is important to match the direction of the belt's inside arrows with the arrows on the machine. The sanding belt will easily break if the arrows are not pointing the same way.

To change/replace sanding belt:

1. DISCONNECT MACHINE FROM POWER!
2. Raise sanding bed off of bed support, as shown in **Figure 27** (see **Adjusting Sanding Bed Angle** on **Page 19**).
3. Pull belt tension release lever out (see **Figure 27**) to release sanding belt tension. The lever will snap into position.

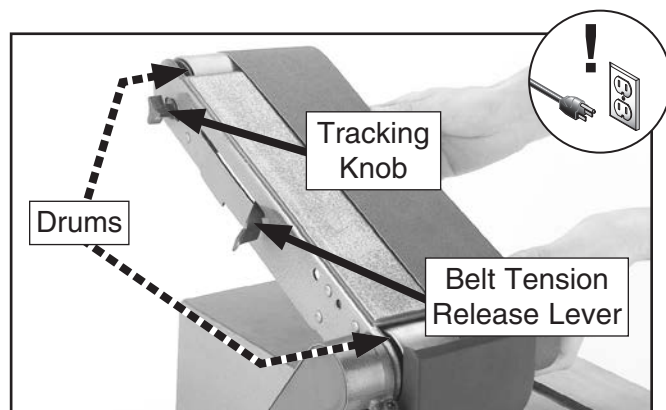

Figure 27. Changing/replacing sanding belt.

4. Remove old sanding belt from sanding bed.
5. Place new sanding belt on bed, then push belt tension lever in to place tension on belt.
Note: Make sure arrow on inside of sanding belt points same direction as belt rotation arrow on machine.
6. Rotate belt by hand to verify belt moves freely without rubbing against any parts of machine.
7. Check and adjust belt tracking (see following instructions).

Adjusting Belt Tracking

The belt tracking needs to be adjusted any time you change or replace the sanding belt, or if the belt moves to one side or the other of the sanding bed during operations.

To check and adjust sanding belt tracking:

1. Remove all tools from sander.
2. Connect machine to power source and turn **ON**, then immediately turn machine **OFF**. Sanding belt should be centered on drums and *not* move toward front or back of sander.

—If sanding belt *does not* move toward front or back, the belt is tracking properly and no further adjustments need to be made.

—If sanding belt *does* move toward front or back, proceed to **Step 3**.

3. If sanding belt moves toward disc (front of sander), rotate tracking knob (see **Figure 26**) clockwise ¼-turn.
4. If sanding belt moves away from disc (toward back of machine), rotate tracking knob counterclockwise ¼-turn.
5. Turn machine **ON**, then immediately turn machine **OFF**. Sanding belt should be centered on drums and *not* move toward front or back of sander. Belt is tracking properly and no further adjustments need to be made.

—If sanding belt *does* move toward front or back, repeat **Steps 3–5** until proper belt tracking is achieved.

Note: Listen for any unusual noises, vibrations, or rubbing while adjusting tracking. If anything sounds unusual, stop sander immediately. Disconnect machine from power source and find source of problem before operating further. If you cannot locate source of unusual noise or vibration, feel free to contact our service department for help.



SECTION 5: ACCESSORIES

!WARNING

Installing unapproved accessories may cause machine to malfunction, resulting in serious personal injury or machine damage. To reduce this risk, only install accessories recommended for this machine by Grizzly.

NOTICE

Refer to our website or latest catalog for additional recommended accessories.

Grizzly® Sanding Belts

These tough aluminium-oxide 4" x 36" sanding belts are sold in a 10-pack.

T21479—Sanding Belt 4" x 36" A/O 60-Grit

T21480—Sanding Belt 4" x 36" A/O 80-Grit

T21481—Sanding Belt 4" x 36" A/O 100-Grit

T21482—Sanding Belt 4" x 36" A/O 120-Grit

T21483—Sanding Belt 4" x 36" A/O 150-Grit

T21484—Sanding Belt 4" x 36" A/O 180-Grit

T21485—Sanding Belt 4" x 36" A/O 220-Grit



Figure 28. Grizzly® sanding belts.

Sanding Discs

These 6" diameter G0547-oxide sanding discs are pre-applied with top-quality pressure sensitive adhesive and sold in a 3-pk.

D1307—Sandpaper Disc 6" A/O 60-Grit

D1308—Sandpaper Disc 6" A/O 80-Grit

D1309—Sandpaper Disc 6" A/O 100-Grit

D1310—Sandpaper Disc 6" A/O 120-Grit

D1311—Sandpaper Disc 6" A/O 150-Grit

D1312—Sandpaper Disc 6" A/O 180-Grit

D1313—Sandpaper Disc 6" A/O 220-Grit



Figure 29. 6" sanding discs.

PRO-STICK® Abrasive Belt and Disc Cleaners

Extend the life of your sanding discs and belts!

W1306—1½" X 1½" X 8½"

W1307—2" X 2" X 12"

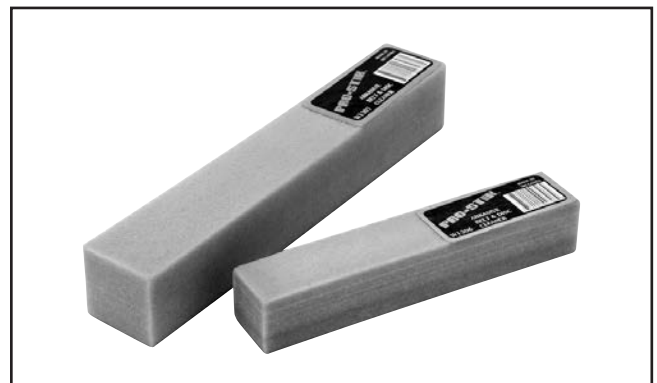

Figure 30. PRO-STICK® abrasive cleaners.

order online at www.grizzly.com or call 1-800-523-4777



D2056—700 Lb. Capacity Shop Fox® Stand

A perfect stand for mounting your smaller machines on. Sturdy and rugged for everyday shop use.



Figure 31. D2056 Shop Fox® Stand.

W1314—Wire Hose Clamp 2½"

W1317—Wire Hose Clamp 4"

W2046—Shop Vacuum Adapter 2½" x 2½"

W1044—Dust Collection Adapter 2½" x 4"

W1053—Anti-Static Grounding Kit

W1007—Plastic Blast Gate 4"

We've hand picked a selection of dust collection components commonly needed to connect the Model G0547 to basic machinery.

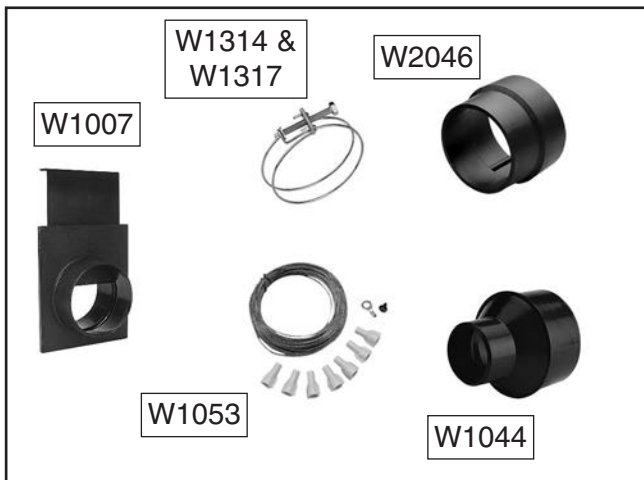

Figure 32. Dust collection accessories.

H2993—4-Pc. Machinist's Square Set

This is a handy set to have around. Each square is finely ground stainless steel. All have common beam and blade widths and thicknesses which will allow them to be used in combination. 2", 3", 4" & 6" squares.

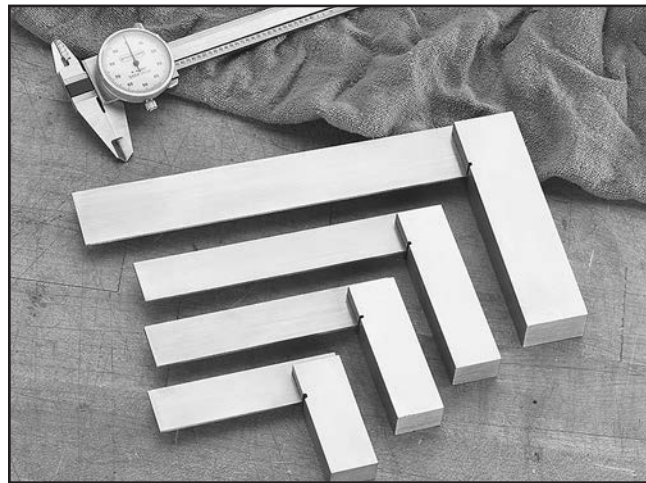

Figure 33. H2993 4-Pc. Square Set.

H7724—60" Birch Workbench w/Drawers

When organized storage is every bit as important as a stable work surface, this workbench is just what you need. Includes six drawers with ball bearing slides and two lower compartments. The end vise also includes two bench dogs. Specifications: 2¾" top edge thickness; 60"W x 20"D x 34"H; 148 lbs. approximate shipping weight.



Figure 34. H7724 60" Birch Workbench with Drawers.



SECTION 6: MAINTENANCE

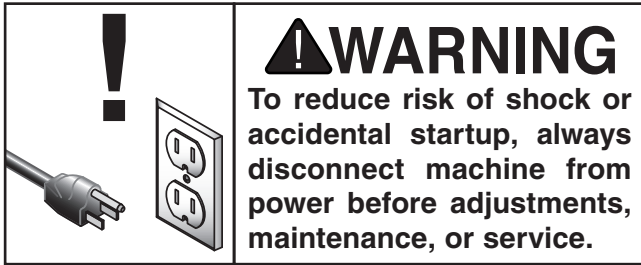

Schedule

For optimum performance from your machine, follow this maintenance schedule and refer to any specific instructions given in this section.

Daily Check

- Loose mounting bolts.
- Worn/damaged sanding disc or sanding belt.
- Worn or damaged wires.
- Any other unsafe condition.

As Needed

- Clean/replace sanding disc or sanding belt.

Monthly Check

- Drive belt tension, damage, or wear.

Cleaning Belt/Disc

Using an abrasive belt/disc cleaner can prolong the life of a clogged sanding belt/disc, provided it is in otherwise good condition. See **Accessories** on **Page 24** for more details.

To clean sanding belt/disc:

1. Turn machine **ON**.
2. Using backstop or work table as support, rub abrasive cleaner on sanding belt/disc in continuous motion, covering entire surface of belt/disc until belt/disc is no longer clogged.
3. Turn machine **OFF**.

Cleaning & Protecting

Cleaning the Model G0547 is relatively easy. Vacuum excess wood chips and sawdust, and wipe off the remaining dust with a dry cloth. If any resin has built up, use a resin-dissolving cleaner to remove it.

Lubricating Sleeve Bearings

Lubricate the sleeve bearing with 30 WT oil every 10 hours of operation. No other lubrication is necessary for this machine.

To lubricate sleeve bearings:

1. DISCONNECT MACHINE FROM POWER!
2. Remove sanding belt (see **Page 23**).
3. Apply two or three drops of oil in hole at end of idler pulley (see **Figure 35**).

Note: *DO NOT apply extra oil. Too much oil can cause the belt to slip.*

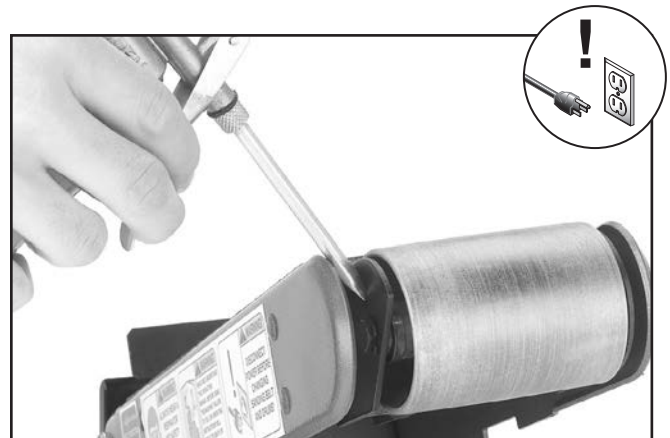

Figure 35. Lubricating sleeve bearings.



SECTION 7: SERVICE

Review the troubleshooting and procedures in this section if a problem develops with your machine. If you need replacement parts or additional help with a procedure, call our Technical Support. **Note:** *Please gather the serial number and manufacture date of your machine before calling.*

Troubleshooting

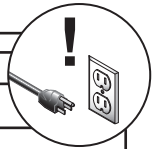

Symptom	Possible Cause	Possible Solution
Machine does not start or a breaker trips.	<ol style="list-style-type: none"> 1. Switch disabling key removed. 2. Incorrect power supply voltage or circuit size. 3. Power supply circuit breaker tripped or fuse blown. 4. Motor wires connected incorrectly. 5. Wiring open/has high resistance. 6. ON/OFF switch at fault. 7. Start capacitor at fault. 8. Motor at fault. 	<ol style="list-style-type: none"> 1. Install switch disabling key (Page 17). 2. Ensure correct power supply voltage and circuit size (Page 9). 3. Ensure circuit is sized correctly and free of shorts. Reset circuit breaker or replace fuse. 4. Correct motor wiring connections (Page 32). 5. Check/fix broken, disconnected, or corroded wires. 6. Replace switch. 7. Test/replace. 8. Test/repair/replace.
Machine stalls or is underpowered.	<ol style="list-style-type: none"> 1. Machine undersized for task. 2. Workpiece material not suitable for machine. 3. Sanding with too much pressure. 4. Workpiece crooked; fence loose or mis-adjusted. 5. Drive belt damaged and slipping. 6. Dust collection ducting problem, causing dust buildup. 7. Dust collector undersized, causing dust buildup. 8. Motor wired incorrectly. 9. Plug/receptacle at fault. 10. Motor overheated. 11. Pulley/sprocket slipping on shaft. 	<ol style="list-style-type: none"> 1. Clean/replace sandpaper (Pages 26 & 22-23); reduce feed rate/sanding depth. 2. Only sand wood—ensure moisture is below 20%. 3. Reduce pressure of workpiece against sanding belt/disc. 4. Straighten or replace workpiece/adjust fence. 5. Inspect/replace drive belt (Page 30). 6. Clear blockages, seal leaks, use smooth wall duct, eliminate bends, close other branches. 7. Move closer to machine/redesign ducting layout/upgrade dust collector. 8. Wire motor correctly (Page 32). 9. Test for good contacts/correct wiring. 10. Clean motor, let cool, and reduce workload. 11. Replace loose pulley/shaft.
Machine has vibration or noisy operation.	<ol style="list-style-type: none"> 1. Machine incorrectly mounted to workbench or floor. 2. Motor or component loose. 3. Motor bearings at fault. 4. Drive belt slapping cover. 5. Sanding disc or drive roller out of balance, damaged, or loose. 	<ol style="list-style-type: none"> 1. Adjust feet, shim, or tighten mounting hardware. 2. Inspect/replace damaged bolts/nuts, and retighten with thread locking fluid. 3. Test by rotating shaft; rotational grinding/loose shaft requires bearing replacement. 4. Replace/tension drive belt. 5. Tighten, adjust, or replace affected component (Page 22).



Symptom	Possible Cause	Possible Solution
Sanding grains easily rub off belt or disc.	<ol style="list-style-type: none"> 1. Sanding belt/disc has been stored in an incorrect environment. 2. Sanding belt/disc has been smashed or folded. 	<ol style="list-style-type: none"> 1. Store sanding belt/disc in a cool, dry area. 2. Store sanding belt/disc flat, and <i>not</i> bent or folded.
Deep sanding grooves or scars in workpiece.	<ol style="list-style-type: none"> 1. Sanding belt/disc too coarse for desired finish. 2. Workpiece sanded across the grain. 3. Too much sanding force on workpiece. 4. Workpiece held still for too long against belt/disc. 	<ol style="list-style-type: none"> 1. Use finer grit sanding belt/disc (Pages 22 & 23). 2. Sand with grain. 3. Reduce pressure on workpiece while sanding. 4. Keep workpiece moving while sanding.
Sanding belt/disc clogs quickly or burns workpiece.	<ol style="list-style-type: none"> 1. Too much pressure on sanding belt/disc. 2. Sanding softwood. 3. Sanding belt/disc clogged. 4. Sanding belt/disc worn or damaged. 	<ol style="list-style-type: none"> 1. Reduce pressure of workpiece against sanding belt/disc. 2. Use different stock, or accept characteristics of stock and plan to clean/replace sanding belt/disc frequently. 3. Clean sanding belt/disc (Page 26). 4. Replace sanding belt/disc (Pages 22 & 23).
Glazed sanding surface.	<ol style="list-style-type: none"> 1. Sanding wet stock. 2. Sanding stock with high amount of residue. 	<ol style="list-style-type: none"> 1. Only sand dry stock. 2. Use different stock, or accept characteristics of stock and plan to clean/replace sanding belt/disc frequently.
Burn marks on workpiece.	<ol style="list-style-type: none"> 1. Sanding grit too fine. 2. Using too much pressure. 3. Workpiece held still for too long. 	<ol style="list-style-type: none"> 1. Use coarser grit sanding belt/disc (Pages 22 & 23). 2. Reduce pressure of workpiece against sanding belt/disc. 3. Keep workpiece moving while sanding.
Workpiece gets pulled out of your hand while belt sanding.	<ol style="list-style-type: none"> 1. Not supporting workpiece against backstop. 	<ol style="list-style-type: none"> 1. Use backstop to support workpiece.
Workpiece lifts up from sanding disc table.	<ol style="list-style-type: none"> 1. Sanding on the upward spinning half of sanding disc. 	<ol style="list-style-type: none"> 1. Sand on downward spinning half of sanding disc.



Positioning Work Table

The work table must be aligned so that the miter slot is parallel to the sanding disc to ensure accurate miter sanding, and it must be spaced approximately $\frac{1}{16}$ " away from the sanding disc to minimize the potential pinch hazard created if the gap between the table and sanding disc is too large.

Work table alignment should be checked and adjusted, if necessary, before each use or any time the work table is removed and re-installed.

To position work table:

1. DISCONNECT MACHINE FROM POWER!
2. Set work table angle to 0° (see **Setting Work Table Angle** on **Page 18**).
3. Check miter slot parallelism by measuring distance from each end of sanding disc to edge of miter slot (see **Figure 36**). Distance "A" should be equal to distance "B" with $\frac{1}{16}$ " gap between table and disc.

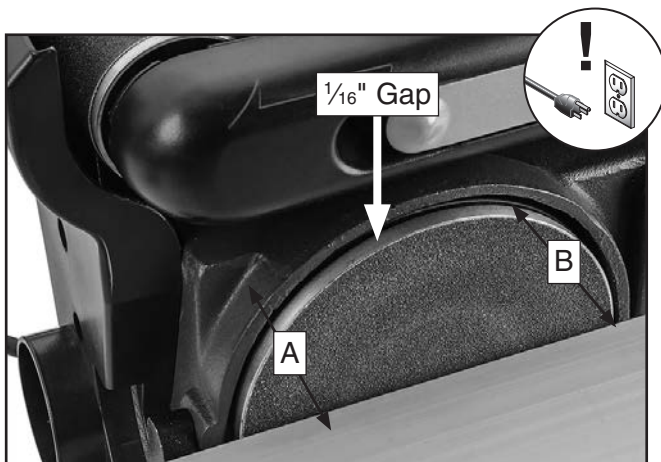

Figure 36. Work table alignment.

—If distance "A" is *not* equal to distance "B" and/or there is *not* a $\frac{1}{16}$ " gap between table and disc, proceed to **Step 4**.

4. Loosen hex bolts that secure table to table support bracket.
5. Adjust table so distance "A" equals distance "B" (**Figure 36**), with $\frac{1}{16}$ " gap between table and sanding disc.
6. Retighten flange nuts from **Step 4**.
7. Re-check miter slot parallelism and spin disc by hand to verify that sanding disc does not touch work table. If necessary, repeat **Steps 4–6** until proper work table alignment is achieved.

Calibrating Miter Gauge

The miter gauge needs to be adjusted perpendicular to the face of the wheel when it is mounted in the table slot.

To check and calibrate miter gauge:

1. DISCONNECT MACHINE FROM POWER!
2. Align work table.
3. Loosen miter gauge lock knob and use a machinist's square with one edge against miter gauge fence and other edge against sanding disc, as shown in **Figure 37**.

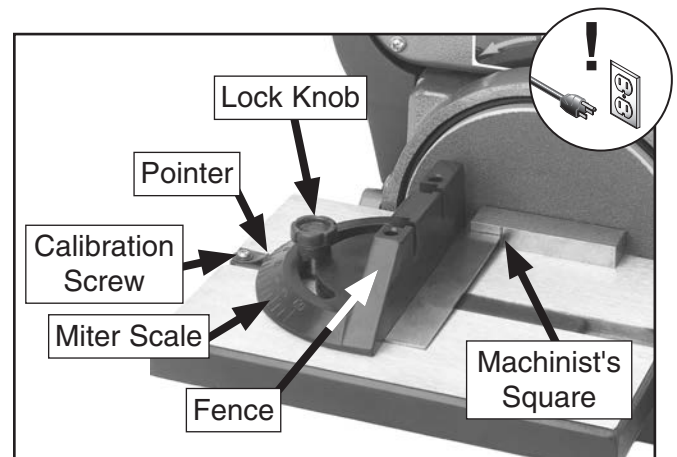

Figure 37. Calibrating miter gauge.



4. Re-tighten lock knob, making sure machinist's square remains flat against both miter gauge fence and sanding disc.
5. Pointer shown in **Figure 37** should point to "0" on the miter scale.

—If the pointer does *not* point to "0" on the miter scale, proceed to **Step 6**.
6. Loosen calibration screw shown in **Figure 37**, and move pointer so it points to "0" on miter scale, making sure fence remains flush with machinist's square.
7. Retighten screw, then verify calibration by repeating **Steps 3–5**.

Replacing Drive Belt

To replace and tension drive belt:

1. DISCONNECT MACHINE FROM POWER!
2. Remove drive belt cover plate (see **Figure 38**).
3. Loosen (3) belt housing screws shown in **Figure 38** to relieve tension on drive belt.

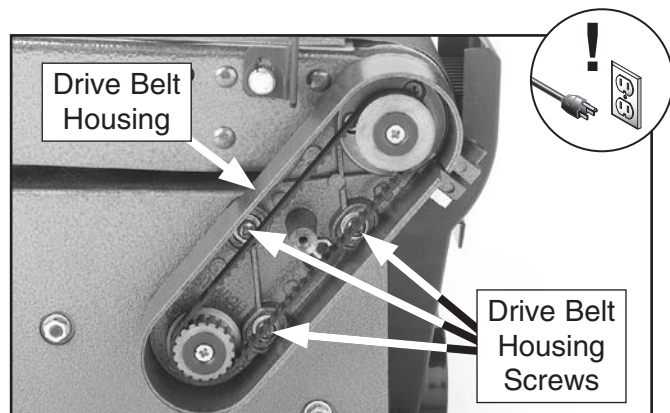

Figure 38. Location of drive belt housing screws.

4. Remove old drive belt and place new drive belt around pulleys.
5. Insert screwdriver into tension hole, as shown in **Figure 39**, and pull up against belt housing to tighten drive belt.

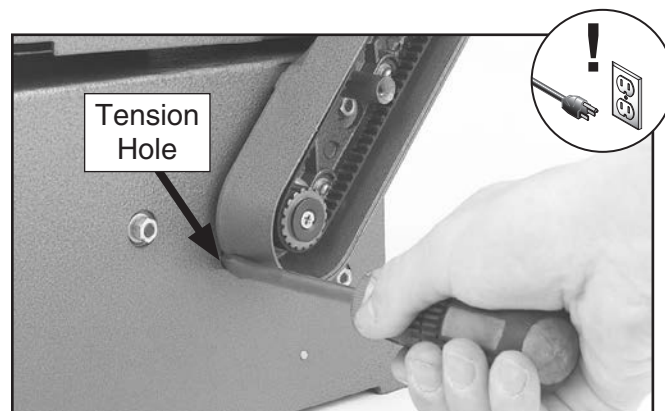

Figure 39. Tensioning drive belt.

6. While keeping tension on belt with screwdriver, use other hand to tighten belt housing screws from **Step 3**.
7. Test belt tension by squeezing belt between your fingers. There should be no more than 1/4" of play in belt.

Note: *Too much tension in belt will cause increased noise and may overload motor. However, if drive belt is too loose, it may slip and cause excessive wear on belt.*
8. Replace drive belt cover plate.



SECTION 8: WIRING

These pages are current at the time of printing. However, in the spirit of improvement, we may make changes to the electrical systems of future machines. Compare the manufacture date of your machine to the one stated in this manual, and study this section carefully.

If there are differences between your machine and what is shown in this section, call Technical Support at (570) 546-9663 for assistance BEFORE making any changes to the wiring on your machine. An updated wiring diagram may be available. **Note:** *Please gather the serial number and manufacture date of your machine before calling. This information can be found on the main machine label.*

WARNING

Wiring Safety Instructions

SHOCK HAZARD. Working on wiring that is connected to a power source is extremely dangerous. Touching electrified parts will result in personal injury including but not limited to severe burns, electrocution, or death. Disconnect the power from the machine before servicing electrical components!

MODIFICATIONS. Modifying the wiring beyond what is shown in the diagram may lead to unpredictable results, including serious injury or fire. This includes the installation of unapproved after-market parts.

WIRE CONNECTIONS. All connections must be tight to prevent wires from loosening during machine operation. Double-check all wires disconnected or connected during any wiring task to ensure tight connections.

CIRCUIT REQUIREMENTS. You MUST follow the requirements at the beginning of this manual when connecting your machine to a power source.

WIRE/COMPONENT DAMAGE. Damaged wires or components increase the risk of serious personal injury, fire, or machine damage. If you notice that any wires or components are damaged while performing a wiring task, replace those wires or components.

MOTOR WIRING. The motor wiring shown in these diagrams is current at the time of printing but may not match your machine. If you find this to be the case, use the wiring diagram inside the motor junction box.















CAPACITORS/INVERTERS. Some capacitors and power inverters store an electrical charge for up to 10 minutes after being disconnected from the power source. To reduce the risk of being shocked, wait at least this long before working on capacitors.

EXPERIENCING DIFFICULTIES. If you are experiencing difficulties understanding the information included in this section, contact our Technical Support at (570) 546-9663.

NOTICE

The photos and diagrams included in this section are best viewed in color. You can view these pages in color at www.grizzly.com.

COLOR KEY

BLACK 	BLUE 	YELLOW 	LIGHT BLUE 
WHITE 	BROWN 	YELLOW GREEN 	BLUE WHITE 
GREEN 	GRAY 	PURPLE 	TURQUOISE 
RED 	ORANGE 	PINK 	



Wiring Diagram

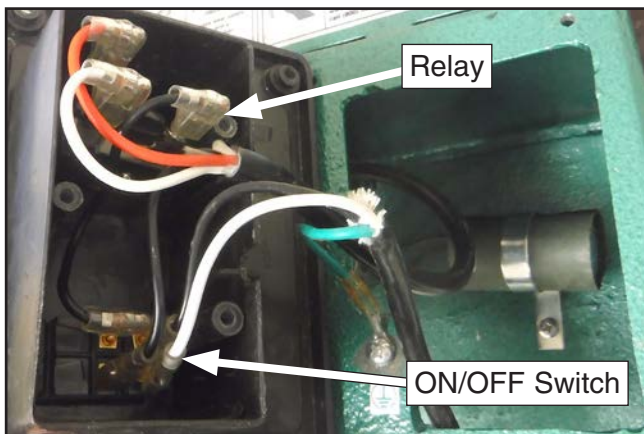
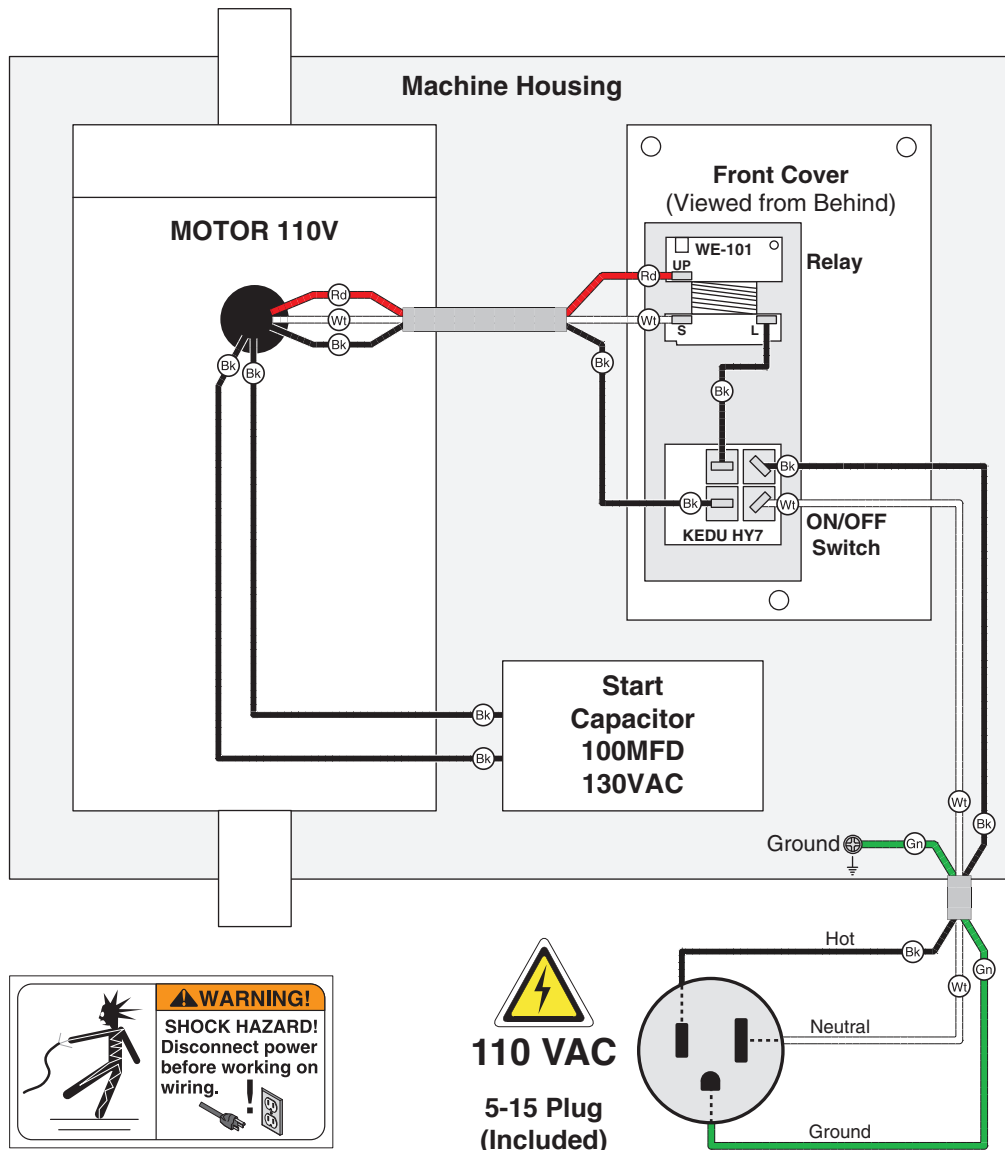

Figure 40. Switch and relay wiring.

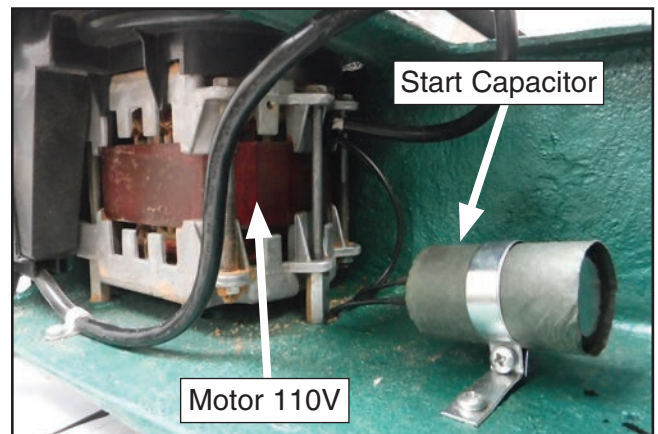
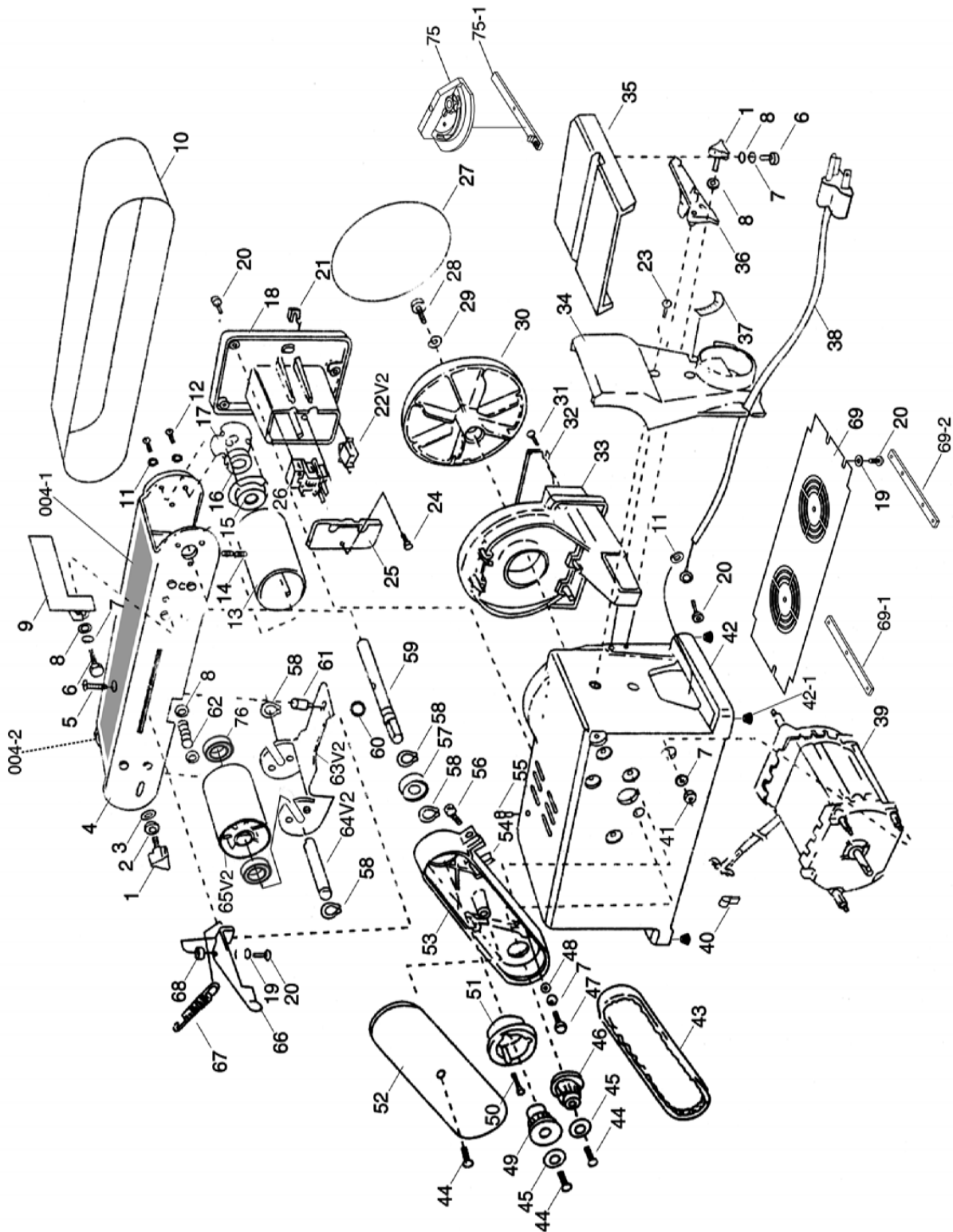

Figure 41. Motor and capacitor wiring.



SECTION 9: PARTS

Main Parts List



Main Breakdown

REF	PART #	DESCRIPTION
1	P0547001	KNOB M6-1 X 30 (MALE)
2	P0547002	RUBBER WASHER 7-16 X 1.7
3	P0547003	NOTCHED WASHER 7-19
4	P0547004	BED
4-1	P0547004-1	GRAPHITE PAD 4-3/8 X 12-1/4"
4-2	P0547004-2	TENSION RELEASE SPRING
5	P0547005	PHLP HD SCR M5-.8 X 35
6	P0547006	HEX BOLT M6-1 X 12
7	P0547007	LOCK WASHER 6MM
8	P0547008	FLAT WASHER 6MM
9	P0547009	BACK STOP
10	P0547010	SANDING BELT 4" X 36"
11	P0547011	LOCK WASHER 5MM
12	P0547012	PHLP HD SCR M5-.8 X 10
13	P0547013	DRIVE DRUM
14	P0547014	SET SCREW M8-1.25 X 10
15	P0547015	BEARING CAP
16	P0547016	BALL BEARING 6001ZZ
17	P0547017	BEARING SPACER
18	P0547018	SWITCH HOUSING
19	P0547019	FLAT WASHER 5MM
20	P0547020	PHLP HD SCR M5-.8 X 8
21	P0547021	YELLOW SWITCH KEY
22	P0547022V2	LOCKING SWITCH V2
23	P0547023	PHLP HD SCR M5-.8 X 20
24	P0547024	TAP SCREW M4 X 25
25	P0547025	SWITCH BOX COVER
26	P0547026	RELAY 110V (ALL WIN)
27	P0547027	6" PSA SANDPAPER DISC
28	P0547028	CAP SCREW M6-1 X 12
29	P0547029	LOCK WASHER 6MM
30	P0547030	DISC
31	P0547031	TAP SCR M4 X 8
32	P0547032	DISC GUARD
33	P0547033	DISC SHROUD
34	P0547034	DUST COLLECTOR
35	P0547035	DISC TABLE
36	P0547036	TABLE SUPPORT
37	P0547037	ANGLE MEASUREMENT LABEL

REF	PART #	DESCRIPTION
38	P0547038	CORD WITH PLUG
39	P0547039	MOTOR 1/3HP 110V 1PH
40	P0547040	WIRE HANGER
41	P0547041	HEX NUT M6-1
42	P0547042	BASE
42-1	P0547042-1	THREADED RUBBER FOOT
43	P0547043	DRIVE BELT 142XL037
44	P0547044	FLAT HD SCR M5-.8 X 10
45	P0547045	COUNTERSUNK WASHER 5MM
46	P0547046	MOTOR PULLEY 15MM BORE
47	P0547047	PHLP HD SCR M6-1 X 25
48	P0547048	FLAT WASHER 6MM
49	P0547049	ARBOR PULLEY 12MM BORE
50	P0547050	FLAT HD SCR M5-.8 X 25
51	P0547051	BEARING HOUSING
52	P0547052	BELT COVER
53	P0547053	BED SUPPORT
54	P0547054	SQUARE NUT M8-1.25
55	P0547055	RUBBER BUMPER
56	P0547056	CAP SCREW M8-1.25 X 25
57	P0547057	BALL BEARING 6001ZZ
58	P0547058	EXT RETAINING RING 12MM
59	P0547059	DRIVE SHAFT
60	P0547060	FLANGE NUT M5-.8
61	P0547061	GUIDE SPACER
62	P0547062	INDEX SPRING 1 X 33.5
63V2	P0547063V2	GUIDE DRUM V2.11.15
64V2	P0547064V2	IDLER SHAFT V2.11.15
65V2	P0547065V2	IDLER DRUM V2.11.15
66	P0547066	TENSION LEVER
67	P0547067	TENSION SPRING 2.5 X 77
68	P0547068	LEVER SPACER
69	P0547069	BOTTOM COVER PLATE
69-1	P0547069-1	COVER PLATE BRKT LEFT 1-HOLE
69-2	P0547069-2	COVER PLATE BRKT RIGHT 2-HOLE
75	P0547075	COMPLETE MITER GAUGE
75-1	P0547075-1	MITER BODY
76	P0547076	BALL BEARING P6001-2RS



Labels & Cosmetics

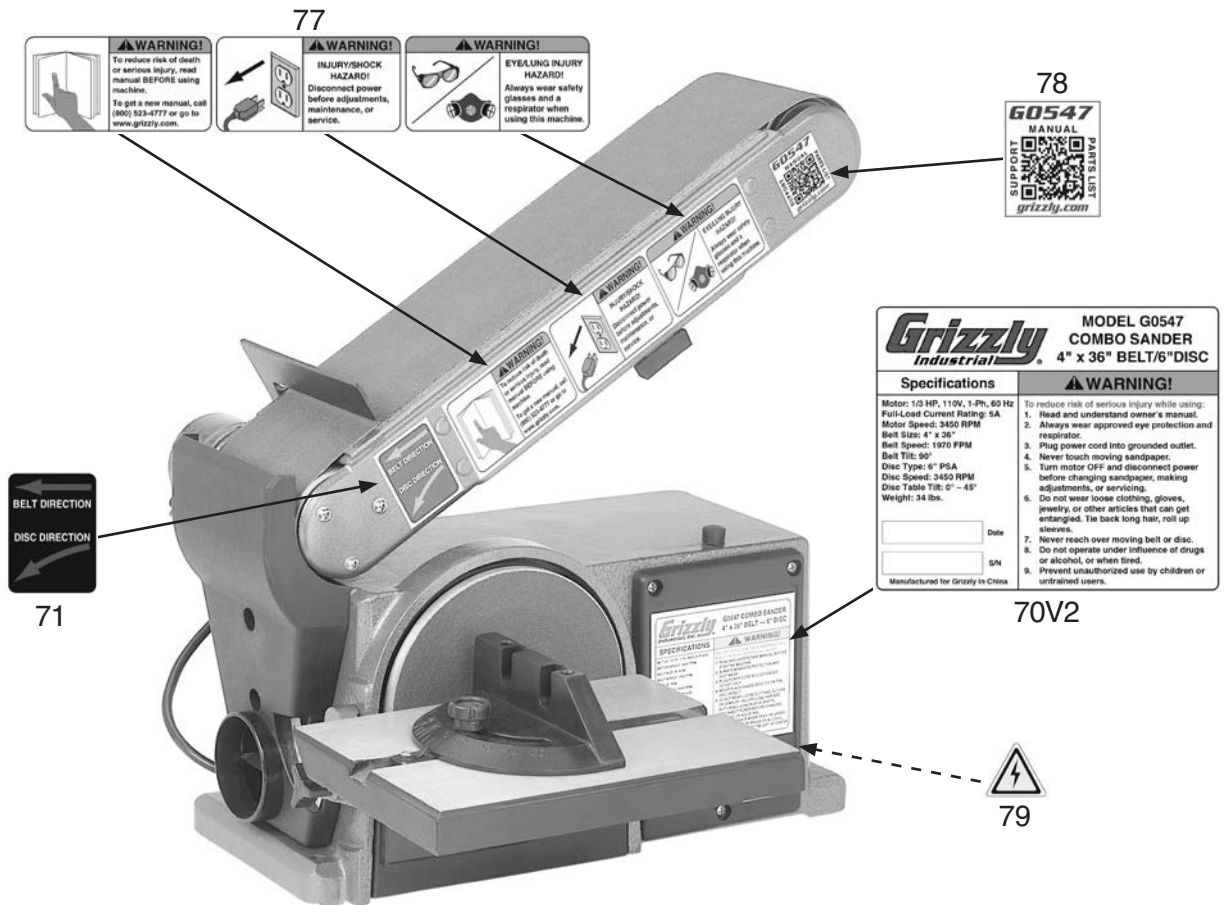

REF	PART #	DESCRIPTION
70V2	P0547070V2	WARNING-ID LABEL V2
71	P0547071	LABEL-BELT DIRECTION
77	P0547077	WARNING LABEL COMBO
78	P0547078	QR CODE
79	P0547079	ELECTRICITY LABEL

Grizzly Industrial MODEL G0547 COMBO SANDER 4" x 36" BELT/6" DISC

Specifications	WARNING!
Motor: 1/2 HP, 110V, 1-Ph, 60 Hz Full-Load Current Rating: 5A Motor Speed: 3450 RPM Belt Size: 4" x 36" Belt Speed: 1970 FPM Belt Tilt: 90° Disc Type: 6" PSA Disc Speed: 3450 RPM Disc Table Tilt: 0° - 45° Weight: 34 lbs.	To reduce risk of serious injury while using: 1. Read and understand owner's manual. 2. Always wear approved eye protection and respirator. 3. Plug power cord into grounded outlet. 4. Never touch moving sandpaper. 5. Turn motor OFF and disconnect power before changing sandpaper, making adjustments, or servicing. 6. Do not wear loose clothing, gloves, jewelry, or other articles that can get entangled. Tie back long hair; roll up sleeves. 7. Never reach over moving belt or disc. 8. Do not operate under influence of drugs or alcohol, or when tired. 9. Prevent unauthorized use by children or untrained users.
_____ Date _____ SN	
Manufactured for Grizzly in China	

⚠ WARNING

Safety labels help reduce the risk of serious injury caused by machine hazards. If any label comes off or becomes unreadable, the owner of this machine **MUST** replace it in the original location before resuming operations. For replacements, contact (800) 523-4777 or www.grizzly.com.





WARRANTY CARD

Name _____
 Street _____
 City _____ State _____ Zip _____
 Phone # _____ Email _____
 Model # _____ Order # _____ Serial # _____

The following information is given on a voluntary basis. It will be used for marketing purposes to help us develop better products and services. **Of course, all information is strictly confidential.**

1. How did you learn about us?

<input type="checkbox"/> Advertisement	<input type="checkbox"/> Friend	<input type="checkbox"/> Catalog
<input type="checkbox"/> Card Deck	<input type="checkbox"/> Website	<input type="checkbox"/> Other:

2. Which of the following magazines do you subscribe to?

<input type="checkbox"/> Cabinetmaker & FDM	<input type="checkbox"/> Popular Science	<input type="checkbox"/> Wooden Boat
<input type="checkbox"/> Family Handyman	<input type="checkbox"/> Popular Woodworking	<input type="checkbox"/> Woodshop News
<input type="checkbox"/> Hand Loader	<input type="checkbox"/> Precision Shooter	<input type="checkbox"/> Woodsmith
<input type="checkbox"/> Handy	<input type="checkbox"/> Projects in Metal	<input type="checkbox"/> Woodwork
<input type="checkbox"/> Home Shop Machinist	<input type="checkbox"/> RC Modeler	<input type="checkbox"/> Woodworker West
<input type="checkbox"/> Journal of Light Cont.	<input type="checkbox"/> Rifle	<input type="checkbox"/> Woodworker's Journal
<input type="checkbox"/> Live Steam	<input type="checkbox"/> Shop Notes	<input type="checkbox"/> Other:
<input type="checkbox"/> Model Airplane News	<input type="checkbox"/> Shotgun News	
<input type="checkbox"/> Old House Journal	<input type="checkbox"/> Today's Homeowner	
<input type="checkbox"/> Popular Mechanics	<input type="checkbox"/> Wood	

3. What is your annual household income?

<input type="checkbox"/> \$20,000-\$29,000	<input type="checkbox"/> \$30,000-\$39,000	<input type="checkbox"/> \$40,000-\$49,000
<input type="checkbox"/> \$50,000-\$59,000	<input type="checkbox"/> \$60,000-\$69,000	<input type="checkbox"/> \$70,000+

4. What is your age group?

<input type="checkbox"/> 20-29	<input type="checkbox"/> 30-39	<input type="checkbox"/> 40-49
<input type="checkbox"/> 50-59	<input type="checkbox"/> 60-69	<input type="checkbox"/> 70+

5. How long have you been a woodworker/metalworker?

<input type="checkbox"/> 0-2 Years	<input type="checkbox"/> 2-8 Years	<input type="checkbox"/> 8-20 Years	<input type="checkbox"/> 20+ Years
------------------------------------	------------------------------------	-------------------------------------	------------------------------------

6. How many of your machines or tools are Grizzly?

<input type="checkbox"/> 0-2	<input type="checkbox"/> 3-5	<input type="checkbox"/> 6-9	<input type="checkbox"/> 10+
------------------------------	------------------------------	------------------------------	------------------------------

7. Do you think your machine represents a good value? Yes No
8. Would you recommend Grizzly Industrial to a friend? Yes No
9. Would you allow us to use your name as a reference for Grizzly customers in your area?
Note: We never use names more than 3 times. Yes No

10. Comments: _____

CUT ALONG DOTTED LINE

FOLD ALONG DOTTED LINE



Place Stamp Here



GRIZZLY INDUSTRIAL, INC.
P.O. BOX 2069
BELLINGHAM, WA 98227-2069



FOLD ALONG DOTTED LINE

Send a Grizzly Catalog to a friend:

Name _____
Street _____
City _____ State _____ Zip _____

TAPE ALONG EDGES--PLEASE DO NOT STAPLE

WARRANTY & RETURNS

Grizzly Industrial, Inc. warrants every product it sells for a period of **1 year** to the original purchaser from the date of purchase. This warranty does not apply to defects due directly or indirectly to misuse, abuse, negligence, accidents, repairs or alterations or lack of maintenance. This is Grizzly's sole written warranty and any and all warranties that may be implied by law, including any merchantability or fitness, for any particular purpose, are hereby limited to the duration of this written warranty. We do not warrant or represent that the merchandise complies with the provisions of any law or acts unless the manufacturer so warrants. In no event shall Grizzly's liability under this warranty exceed the purchase price paid for the product and any legal actions brought against Grizzly shall be tried in the State of Washington, County of Whatcom.

We shall in no event be liable for death, injuries to persons or property or for incidental, contingent, special, or consequential damages arising from the use of our products.

To take advantage of this warranty, contact us by mail or phone and give us all the details. We will then issue you a "Return Number," which must be clearly posted on the outside as well as the inside of the carton. We will not accept any item back without this number. Proof of purchase must accompany the merchandise.

The manufacturers reserve the right to change specifications at any time because they constantly strive to achieve better quality equipment. We make every effort to ensure that our products meet high quality and durability standards and we hope you never need to use this warranty.

Please feel free to write or call us if you have any questions about the machine or the manual.

Thank you again for your business and continued support. We hope to serve you again soon.

grizzly.com[®]

TOOL WEBSITE

Buy Direct and Save with Grizzly[®] – Trusted, Proven and a Great Value!
~Since 1983~

*Visit Our Website Today For
Current Specials!*

**ORDER
24 HOURS A DAY!
1-800-523-4777**

