

Grizzly ***Industrial, Inc.***®

MODEL G0463 SMALL MILL/DRILL OWNER'S MANUAL

(FOR MODELS MANUFACTURED AFTER 2/09)



COPYRIGHT © NOVEMBER, 2005 BY GRIZZLY INDUSTRIAL, INC., REVISED JUNE, 2015 (ST)

**WARNING: NO PORTION OF THIS MANUAL MAY BE REPRODUCED IN ANY SHAPE
OR FORM WITHOUT THE WRITTEN APPROVAL OF GRIZZLY INDUSTRIAL, INC.**

#PC7741 PRINTED IN CHINA



WARNING!

Some dust created by power sanding, sawing, grinding, drilling, and other construction activities contains chemicals known to the State of California to cause cancer, birth defects or other reproductive harm. Some examples of these chemical are:

- Lead from lead-based paints.
- Crystalline silica from bricks, cement and other masonry products.
- Arsenic and chromium from chemically-treated lumber.

Your risk from these exposures varies, depending on how often you do this type of work. To reduce your exposure to these chemicals: Work in a well ventilated area, and work with approved safety equipment, such as those dust masks that are specially designed to filter out microscopic particles.

WARNING

Safety labels warn about machine hazards and ways to prevent injury. The owner of this machine **MUST** maintain the original location and readability of the labels on the machine. If any label is removed or becomes unreadable, **REPLACE** that label before using the machine again. Contact Grizzly at (800) 523-4777 or www.grizzly.com to order new labels.

Table of Contents

INTRODUCTION	3
Foreword	3
Contact Info	3
Identification	6
SECTION 1: SAFETY	7
Safety Instructions for Machinery	7
Additional Safety for Mill/Drills.....	9
SECTION 2: CIRCUIT REQUIREMENTS	10
110V Operation	10
SECTION 3: SET UP	11
Set Up Safety	11
Items Needed for Set Up	11
Unpacking	11
Inventory.....	12
Clean Up	13
Site Considerations	13
Feet	14
Mounting to Workbench	14
Test Run and Spindle Break-in	15
Drill Chuck Removal.....	16
R-8 Collets.....	17
SECTION 4: OPERATIONS	18
Operation Safety	18
Power Controls.....	18
Power Shutdown	19
Spindle & Headstock Controls	19
Table Travel	20
Setting RPM	21
SECTION 5: ACCESSORIES	22
SECTION 6: MAINTENANCE	24
Schedule	24
Unpainted Cast Iron	24
Lubrication.....	24
SECTION 7: SERVICE	25
About Service	25
Troubleshooting.....	25
Adjusting Gibs	26
Replacing Motor Brushes & Fuse	26
Electrical Components	27
Wiring Diagram.....	28
Parts Breakdown	29
Parts List	31
WARRANTY AND RETURNS	34

INTRODUCTION

Foreword

We are proud to offer the Model G0463 Small Mill/Drill. This machine is part of a growing Grizzly family of fine metalworking machinery. When used according to the guidelines set forth in this manual, you can expect years of trouble-free, enjoyable operation and proof of Grizzly's commitment to customer satisfaction.

We are pleased to provide this manual with the Model G0463. It was written to guide you through assembly, review safety considerations, and cover general operating procedures. It represents our effort to produce the best documentation possible.

The specifications, drawings, and photographs illustrated in this manual represent the Model G0463 as supplied when the manual was prepared. However, owing to Grizzly's policy of continuous improvement, changes may be made at any time with no obligation on the part of Grizzly. For your convenience, we always keep current Grizzly manuals available on our website at **www.grizzly.com**. Any updates to your machine will be reflected in these manuals as soon as they are complete. Visit our site often to check for the latest updates to this manual!

Contact Info

If you have any comments regarding this manual, please write to us at the address below:

Grizzly Industrial, Inc.
c/o Technical Documentation Manager
P.O. Box 2069
Bellingham, WA 98227-2069

We stand behind our machines. If you have any service questions or parts requests, please call or write us at the location listed below.

Grizzly Industrial, Inc.
1203 Lycoming Mall Circle
Muncy, PA 17756
Phone: (570) 546-9663
Fax: (800) 438-5901
E-Mail: techsupport@grizzly.com
Web Site: <http://www.grizzly.com>





MACHINE DATA SHEET

Customer Service #: (570) 546-9663 · To Order Call: (800) 523-4777 · Fax #: (800) 438-5901

MODEL G0463 MILL / DRILL

Product Dimensions:

Weight..... 353 lbs.
 Width (side-to-side) x Depth (front-to-back) x Height..... 27 x 30 x 30-3/4 in.
 Footprint (Length x Width)..... 16 x 13 in.
 Space Required for Full Range of Movement (Width x Depth)..... 45-3/4 x 30 in.

Shipping Dimensions:

Type..... Wood Crate
 Content..... Machine
 Weight..... 445 lbs.
 Length x Width x Height..... 32 x 32 x 40 in.
 Must Ship Upright..... Yes

Electrical:

Power Requirement..... 110V, Single-Phase, 60 Hz
 Prewired Voltage..... 110V
 Full-Load Current Rating..... 7A
 Minimum Circuit Size..... 15A
 Connection Type..... Cord & Plug
 Power Cord Included..... Yes
 Power Cord Length..... 7 ft.
 Power Cord Gauge..... 16 AWG
 Plug Included..... Yes
 Included Plug Type..... 5-15
 Switch Type..... Forward/Reverse & Button Switches

Motors:

Main

Type..... Universal
 Horsepower..... 3/4 HP
 Phase..... Single-Phase
 Amps..... 7A
 Speed..... 0 – 3725 RPM
 Power Transfer Belt Drive
 Bearings..... Sealed & Permanently Lubricated

Main Specifications:

Operation Info

Spindle Travel..... 3-3/8 in.
 Max Distance Spindle to Column..... 9 in.
 Max Distance Spindle to Table..... 14-3/4 in.
 Longitudinal Table Travel (X-Axis)..... 15-7/8 in.
 Cross Table Travel (Y-Axis)..... 5-3/4 in.
 Vertical Head Travel (Z-Axis)..... 14-7/8 in.
 Drilling Capacity for Cast Iron..... 1 in.
 Drilling Capacity for Steel..... 1 in.
 End Milling Capacity..... 1 in.
 Face Milling Capacity..... 2 in.



Table Info

Table Length.....	21-5/8 in.
Table Width.....	6-1/4 in.
Table Thickness.....	1-1/2 in.
Number of T-Slots.....	3
T-Slot Size.....	7/16 in.
T-Slots Centers.....	1-11/16 in.
X/Y-Axis Travel per Handwheel Revolution.....	0.100 in.

Spindle Info

Spindle Taper.....	R-8
Number of Vertical Spindle Speeds.....	Variable
Range of Vertical Spindle Speeds.....	0 – 2000 RPM
Quill Diameter.....	2.362 in.
Drawbar Thread Size.....	7/16-20
Drawbar Length.....	10-3/4 in.
Spindle Bearings.....	Ball Bearings

Construction

Spindle Housing/Quill.....	Cast Iron
Table.....	Ground Cast Iron
Head.....	Cast Iron
Column/Base.....	Cast Iron
Base.....	Cast Iron
Paint Type/Finish.....	Enamel

Other Specifications:

Country of Origin	China
Warranty	1 Year
Approximate Assembly & Setup Time	30 Minutes
Serial Number Location	ID Label on Top of Column
ISO 9001 Factory	Yes
Certified by a Nationally Recognized Testing Laboratory (NRTL)	No

Features:

- Variable Spindle Speed from 0 - 2000 RPM
- Dovetail Column with Handwheel Graduated in .0005"
- Almost 14" of Headstock Movement
- Reversing Switch
- Coolant Trough
- Push Button Emergency Switch with Indicator Lights

Accessories Included:

- 2 T-nuts
- 3 Open End Combo Wrenches
- 4 Allen Wrenches
- 4 Leveling Feet
- 5/8" Drill Chuck with Arbor
- Extra Drive Belt



Identification

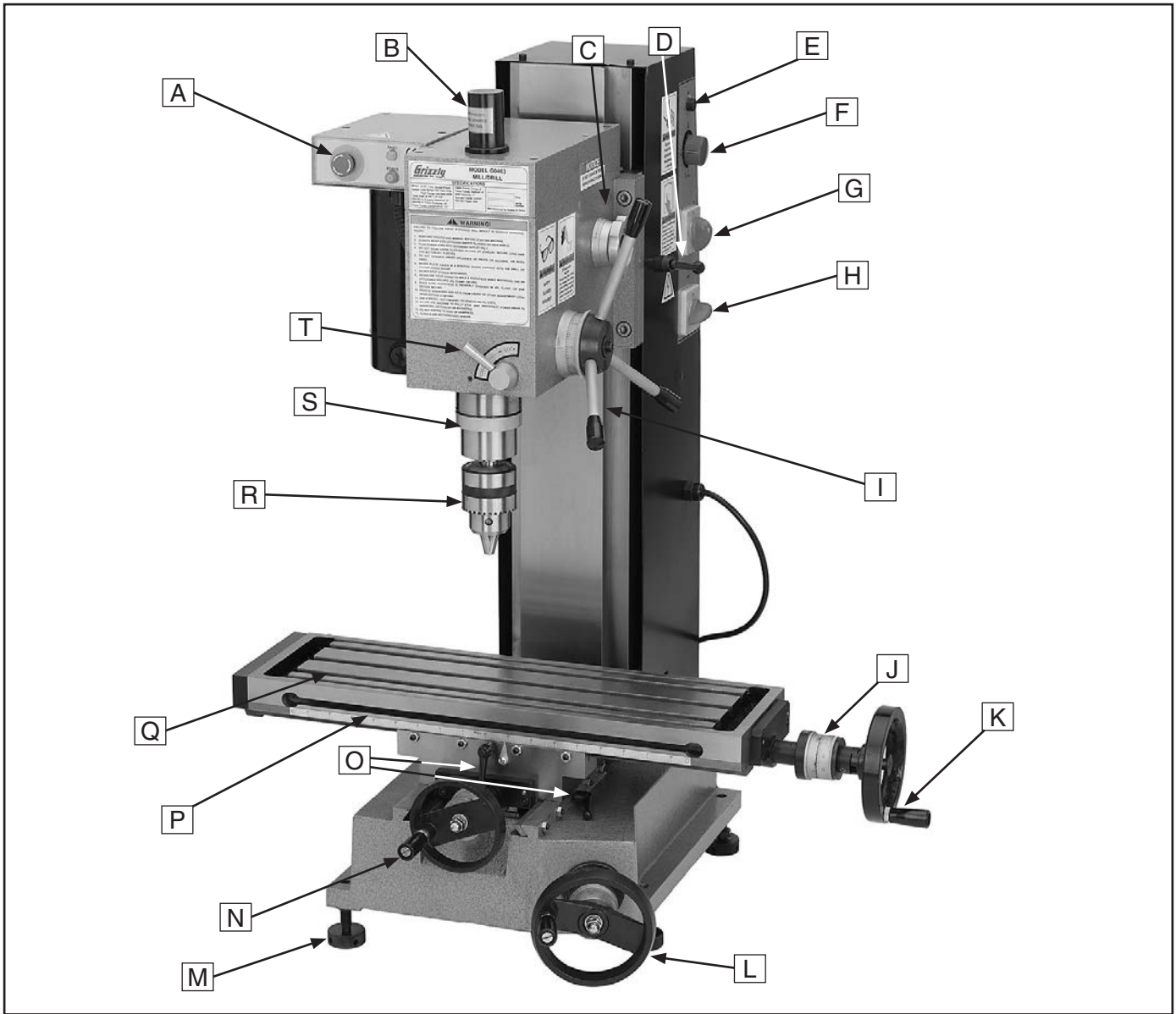

Figure 1. G0463 Identification.

- | | |
|------------------------------|------------------------------------|
| A. Emergency Stop Button | K. Longitudinal (X-Axis) Handwheel |
| B. Drawbar (under cover) | L. Vertical (Z Axis) Handwheel |
| C. High/Low Gear Change Knob | M. Adjustable Feet |
| D. Headstock Lock | N. Cross (Y-Axis) Handwheel |
| E. Fuse Socket | O. Table Locks |
| F. Spindle RPM Control | P. Longitudinal Scale |
| G. Forward/Reverse Switch | Q. T-Slots and Coolant Trough |
| H. Main Power Switch | R. Drill Chuck |
| I. Quill Feed Levers | S. Quill |
| J. Graduated Dials | T. Quill Lock |



SECTION 1: SAFETY

WARNING

For Your Own Safety, Read Instruction Manual Before Operating this Machine

The purpose of safety symbols is to attract your attention to possible hazardous conditions. This manual uses a series of symbols and signal words which are intended to convey the level of importance of the safety messages. The progression of symbols is described below. Remember that safety messages by themselves do not eliminate danger and are not a substitute for proper accident prevention measures.

 **DANGER** Indicates an imminently hazardous situation which, if not avoided, **WILL** result in death or serious injury.

 **WARNING** Indicates a potentially hazardous situation which, if not avoided, **COULD** result in death or serious injury.

 **CAUTION** Indicates a potentially hazardous situation which, if not avoided, **MAY** result in minor or moderate injury. It may also be used to alert against unsafe practices.

NOTICE This symbol is used to alert the user to useful information about proper operation of the machine.

WARNING

Safety Instructions for Machinery

- 1. READ THROUGH THE ENTIRE MANUAL BEFORE STARTING MACHINERY.** Machinery presents serious injury hazards to untrained users.
- 2. ALWAYS USE ANSI APPROVED SAFETY GLASSES WHEN OPERATING MACHINERY.** Everyday eyeglasses only have impact resistant lenses, they are NOT safety glasses.
- 3. ALWAYS WEAR AN ANSI APPROVED RESPIRATOR WHEN OPERATING MACHINERY THAT PRODUCES DUST.** Wood dust is a carcinogen and can cause cancer and severe respiratory illnesses.
- 4. ALWAYS USE HEARING PROTECTION WHEN OPERATING MACHINERY.** Machinery noise can cause permanent hearing damage.
- 5. WEAR PROPER APPAREL. DO NOT** wear loose clothing, gloves, neckties, rings, or jewelry which may get caught in moving parts. Wear protective hair covering to contain long hair and wear non-slip footwear.
- 6. NEVER OPERATE MACHINERY WHEN TIRED, OR UNDER THE INFLUENCE OF DRUGS OR ALCOHOL.** Be mentally alert at all times when running machinery.



WARNING

Safety Instructions for Machinery

7. **ONLY ALLOW TRAINED AND PROPERLY SUPERVISED PERSONNEL TO OPERATE MACHINERY.** Make sure operation instructions are safe and clearly understood.
8. **KEEP CHILDREN AND VISITORS AWAY.** Keep all children and visitors a safe distance from the work area.
9. **MAKE WORKSHOP CHILD PROOF.** Use padlocks, master switches, and remove start switch keys.
10. **NEVER LEAVE WHEN MACHINE IS RUNNING.** Turn power **OFF** and allow all moving parts to come to a complete stop before leaving machine unattended.
11. **DO NOT USE IN DANGEROUS ENVIRONMENTS.** DO NOT use machinery in damp, wet locations, or where any flammable or noxious fumes may exist.
12. **KEEP WORK AREA CLEAN AND WELL LIT.** Clutter and dark shadows may cause accidents.
13. **USE A GROUNDED EXTENSION CORD RATED FOR THE MACHINE AMPERAGE.** Undersized cords overheat and lose power. Replace extension cords if they become damaged. DO NOT use extension cords for 220V machinery.
14. **ALWAYS DISCONNECT FROM POWER SOURCE BEFORE SERVICING MACHINERY.** Make sure switch is in OFF position before reconnecting.
15. **MAINTAIN MACHINERY WITH CARE.** Keep blades sharp and clean for best and safest performance. Follow instructions for lubricating and changing accessories.
16. **MAKE SURE GUARDS ARE IN PLACE AND WORK CORRECTLY BEFORE USING MACHINERY.**
17. **REMOVE ADJUSTING KEYS AND WRENCHES.** Make a habit of checking for keys and adjusting wrenches before turning machinery **ON**.
18. **CHECK FOR DAMAGED PARTS BEFORE USING MACHINERY.** Check for binding and alignment of parts, broken parts, part mounting, loose bolts, and any other conditions that may affect machine operation. Repair or replace damaged parts.
19. **USE RECOMMENDED ACCESSORIES.** Refer to the instruction manual for recommended accessories. The use of improper accessories may cause risk of injury.
20. **DO NOT FORCE MACHINERY.** Work at the speed for which the machine or accessory was designed.
21. **SECURE WORKPIECE.** Use clamps or a vise to hold the workpiece when practical. A secured workpiece protects your hands and frees both hands to operate the machine.
22. **DO NOT OVERREACH.** Keep proper footing and balance at all times.
23. **MANY MACHINES WILL EJECT THE WORKPIECE TOWARD THE OPERATOR.** Know and avoid conditions that cause the workpiece to "kickback."
24. **ALWAYS LOCK MOBILE BASES (IF USED) BEFORE OPERATING MACHINERY.**
25. **BE AWARE THAT CERTAIN DUST MAY BE HAZARDOUS** to the respiratory systems of people and animals, especially fine dust. Make sure you know the hazards associated with the type of dust you will be exposed to and always wear a respirator approved for that type of dust.



WARNING

Additional Safety for Mill/Drills

- 1. UNDERSTANDING CONTROLS.** Make sure you understand the use and operation of all controls.
- 2. SAFETY ACCESSORIES.** Always use a chip guard in addition to your safety glasses when milling to prevent bodily injury.
- 3. WORK HOLDING.** Before starting the machine, be certain the workpiece has been properly clamped to the table. NEVER hold the workpiece by hand when using the mill.
- 4. CHUCK KEY SAFETY.** Always remove your chuck key, drawbar wrench, and any service tools immediately after use.
- 5. SPINDLE SPEEDS.** Select the spindle speed that is appropriate for the type of work and material. Allow the mill/drill to gain full speed before beginning a cut.
- 6. POWER DISRUPTION.** In the event of a local power outage during use of the mill, turn **OFF** all switches to avoid possible sudden start up once power is restored.
- 7. SPINDLE DIRECTION CHANGES.** Never reverse spindle direction while the mill/drill is in motion.
- 8. STOPPING SPINDLE.** DO NOT stop the mill/drill using your hand against the chuck.
- 9. BE ATTENTIVE.** DO NOT leave mill/drill running unattended for any reason.
- 10. MACHINE CARE AND MAINTENANCE.** Never operate the mill/drill with damaged or worn parts. Maintain your mill/drill in proper working condition. Perform routine inspections and maintenance promptly. Put away adjustment tools after use.
- 11. DISCONNECT POWER.** Make sure the mill is turned **OFF**, disconnected from its power source and all moving parts have come to a complete stop before starting any inspection, adjustment, or maintenance procedure.
- 12. AVOIDING ENTANGLEMENT.** Keep loose clothing articles such as sleeves, belts or jewelry items away from the mill spindle. Never wear gloves when operating the mill.
- 13. TOOL HOLDING.** Always use the proper tools for the material you are milling. Make sure they are held firmly in the proper tool holder for the job.
- 14. CLEAN-UP.** DO NOT clear chips by hand. Use a brush, and never clear chips while the mill is turning.
- 15. CUTTING TOOL INSPECTION.** Inspect drills and end mills for sharpness, chips, or cracks before each use. Replace dull, chipped, or cracked cutting tools immediately. Handle new cutting tools with care. Leading edges are very sharp and can cause lacerations.
- 13. EXPERIENCING DIFFICULTIES.** If at any time you are experiencing difficulties performing the intended operation, stop using the machine! Contact our Technical Support at (570) 546-9663.

WARNING

No list of safety guidelines can be complete. Every shop environment is different. Like all machines there is danger associated with the Model G0463. Accidents are frequently caused by lack of familiarity or failure to pay attention. Use this machine with respect and caution to lessen the possibility of operator injury. If normal safety precautions are overlooked or ignored, serious personal injury may occur.



SECTION 2: CIRCUIT REQUIREMENTS

110V Operation

!WARNING

Serious personal injury could occur if you connect the machine to the power source before you have completed the set up process. **DO NOT** connect the machine to the power source until instructed to do so.

Amperage Draw

The Model G0463 motor draws the following amps under maximum load:

Motor Draw 7 Amps

Circuit Recommendations

We recommend connecting this machine to a dedicated circuit with a verified ground, using the circuit breaker size given below. Never replace a circuit breaker with one of higher amperage without consulting a qualified electrician to ensure compliance with wiring codes. **If you are unsure about the wiring codes in your area or you plan to connect your machine to a shared circuit, you may create a fire hazard—consult a qualified electrician to reduce this risk.**

Circuit Breaker..... 10 Amps

Plug/Receptacle Type

Included Plug Type..... NEMA 5-15

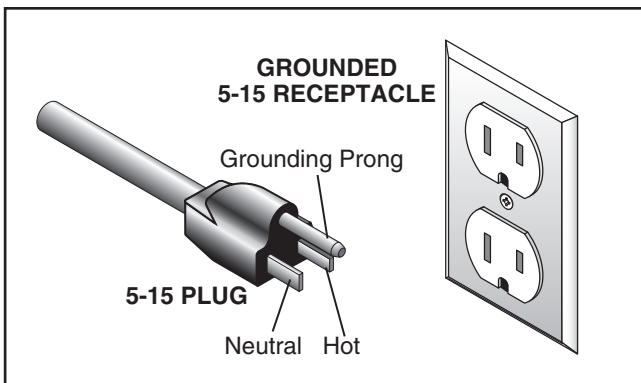

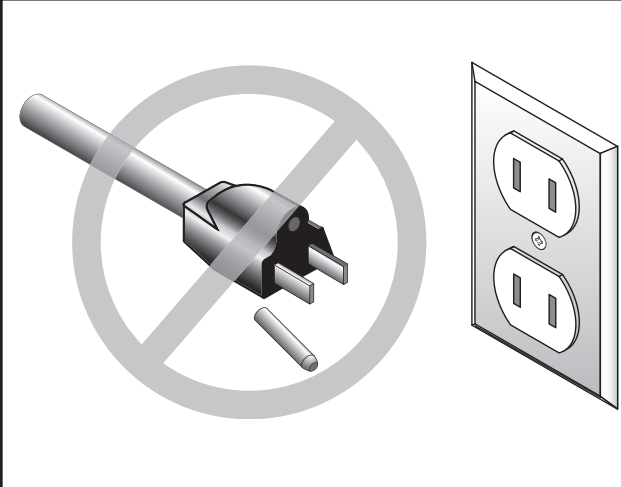

Figure 2. A 5-15 plug and receptacle.



!WARNING

Electrocution or fire could result if this machine is not grounded correctly or if your electrical configuration does not comply with local and state codes. Ensure compliance by checking with a qualified electrician!



!CAUTION

This machine must have a ground prong in the plug to help ensure that it is grounded. **DO NOT** remove ground prong from plug to fit into a two-pronged outlet! If the plug will not fit the outlet, have the proper outlet installed by a qualified electrician.

Extension Cords

We do not recommend the use of extension cords, if you find it absolutely necessary:

- Use at least a 16 gauge cord that does not exceed 50 feet in length!
- The extension cord must also contain a ground wire and plug pin.
- A qualified electrician **MUST** size cords over 50 feet long to prevent motor damage.



SECTION 3: SET UP

Set Up Safety

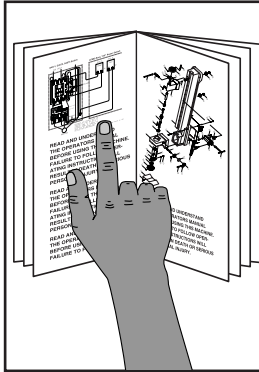

!WARNING

This machine presents serious injury hazards to untrained users. Read through this entire manual to become familiar with the controls and operations before starting the machine!

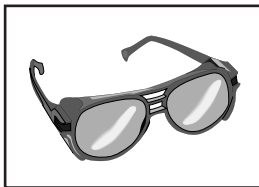

!WARNING

Wear safety glasses during the entire set up process!

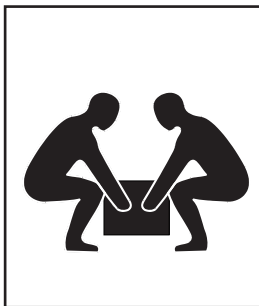

!WARNING

The Model G0463 is a heavy machine. DO NOT over-exert yourself while unpacking or moving your machine—get assistance.

Items Needed for Set Up

The following items are needed to complete the set up process, but are not included with your machine:

Description	Qty
• Precision Level	1
• Safety Glasses (for each person)	1
• Solvent	1
• Shop Rags.....	1
• Metal Shim Stock	1
• Brass Hammer	1
• Power Drill (optional)	1
• Drill Bit 9/16"(optional).....	1
• Hex Bolts M12-1.75 (length as needed)	4
• Flat Washers 12mm	8
• Lock Washers 12mm	4
• Hex Nuts M12-1.75	4
• An Assistant	1

Unpacking

The Model G0463 was carefully packed when it left our warehouse. If you discover the machine is damaged after you have signed for delivery, *please immediately call Customer Service at (570) 546-9663 for advice.*

Save the containers and all packing materials for possible inspection by the carrier or its agent. *Otherwise, filing a freight claim can be difficult.*

When you are completely satisfied with the condition of your shipment, you should inventory the contents.



Inventory

After all the parts have been removed from the two boxes, you should have the following items:

Box 1: (Figures 3 & 4)	Qty
A. Mill/Drill with Chuck.....	1
B. Oil Bottle.....	1
C. End Wrenches 8/10, 12/14, 17/19mm	1 ea
D. Chuck Key	1
E. Hex Wrenches 3, 4, 5 & 6mm.....	1 ea
F. Feet with Hex Nut M12-1.75.....	4
G. T-Nuts $\frac{3}{8}$ "	2
H. Pin Spanner Wrench	1

Items not shown:

Spare Fuse	1
------------------	---



Figure 3. G0463 out of the crate.

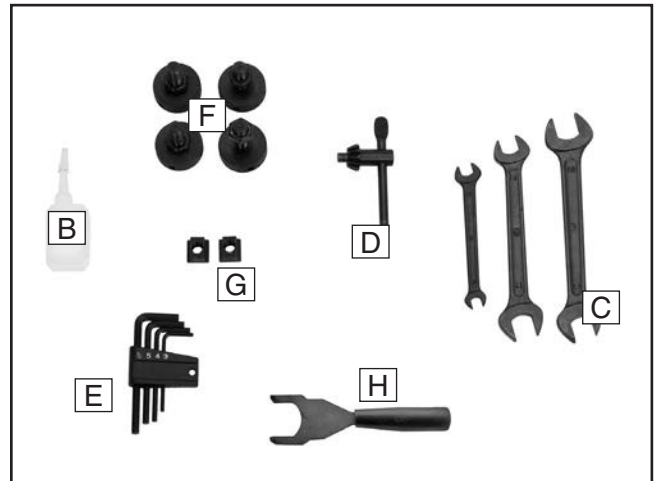



Figure 4. Loose inventory.

In the event that any nonproprietary parts are missing (e.g. a nut or a washer), we would be glad to replace them, or for the sake of expediency, replacements can be obtained at your local hardware store.



Clean Up

The unpainted surfaces are coated with a waxy oil to protect them from corrosion during shipment. Remove this protective coating with a solvent cleaner or citrus-based degreaser such as Grizzly's G7895 Degreaser. To clean thoroughly, some parts may need to be removed. **For optimum performance from your machine, make sure you clean all moving parts or sliding contact surfaces that are coated.** Avoid chlorine-based solvents, such as acetone or brake parts cleaner, as they may damage painted surfaces should they come in contact. Always follow the manufacturer's instructions when using any type of cleaning product.

	<p>⚠️ WARNING Gasoline and petroleum products have low flash points and could cause an explosion or fire if used to clean machinery. DO NOT use gasoline or petroleum products to clean the machinery.</p>
--	--

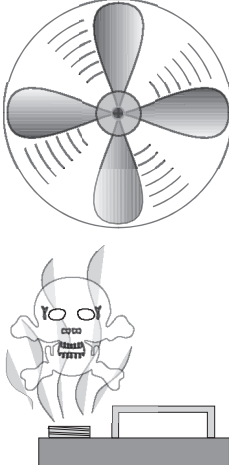
	<p>⚠️ CAUTION Many of the solvents commonly used to clean machinery can be toxic when inhaled or ingested. Lack of ventilation while using these solvents could cause serious personal health risks or fire. Take precautions from this hazard by only using cleaning solvents in a well ventilated area.</p>
---	--

Site Considerations

Workbench Load

Although adjustable feet are included with your mill/drill, it is strongly recommended you bolt your machine to a sturdy workbench that will not tip. Refer to the **Machine Data Sheet** for the weight and footprint specifications of your machine. Some workbenches may require additional reinforcement to support both the machine and the workpiece.

Working Clearances

Consider existing and anticipated needs, size of material to be processed through each machine, and space for auxiliary stands, work tables or other machinery when establishing a location for your new machine. See **Figure 5** for the minimum working clearances.

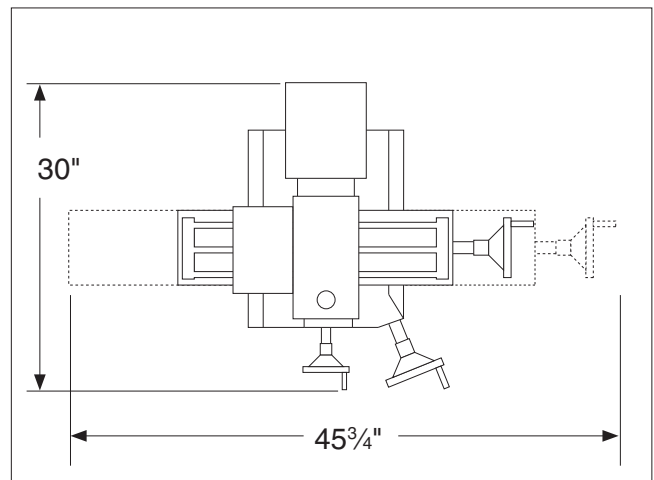

Figure 5. Minimum working clearances.

	<p>⚠️ CAUTION Unsupervised children and visitors inside your shop could cause serious personal injury to themselves. Lock all entrances to the shop when you are away and DO NOT allow unsupervised children or visitors in your shop at any time!</p>
--	--



Feet

Four leveling feet have been included with your mill/drill. However, for greater safety and better performance, we recommend bolting your machine to a sturdy workbench.

Components and Hardware Needed:	Qty
Foot with Hex Nut M12-1.75.....	4

To adjust the feet on the mill/drill:

1. Place your precision level on the mill/drill table.
2. Loosen the hex nut(s), as shown in **Figure 7**, and turn the feet until the mill/drill is level side-to-side and front-to-back.



3. Retighten the hex nuts.

Mounting to Workbench

The Model G0463 should be bolted to a workbench to provide maximum rigidity and safety.

Components and Hardware Needed:	Qty
Hex Bolts M12-1.75 x (length as needed).....	4
Flat Washers 12mm.....	8
Lock Washers 12mm.....	4
Hex Nuts M12-1.75.....	4

To mount the mill/drill to the workbench:

1. Determine the best position for the mill/drill on the workbench.

Note: For the best performance, make sure the cross feed and the longitudinal handwheels extend out beyond the edge of the table surface. This will allow unrestricted handwheel operation.

2. Mark your hole locations using the mounting holes in the base as a guide.
3. Drill the holes needed in the workbench.
4. Place a precision level on the mill/drill table and shim the mill/drill until it is level side-to-side and front-to-back.
5. Bolt the mill/drill to the workbench.



Test Run and Spindle Break-in

The Model G0463 has two speed ranges: Low range is 0–1000; high range is 0–2000 RPM.

It is essential to closely follow the proper break-in procedures to ensure trouble free performance. Complete this process once you have familiarized yourself with all instructions in this manual.

To begin the start up and break-in procedure:

1. Follow all lubrication procedures highlighted in **Lubrication** in **Section 6: MAINTENANCE** on **Page 24**.
2. Make sure there are no obstructions around or underneath the spindle. Remove the drawbar if there is no arbor or collet in the spindle.
3. With the spindle at a complete stop, shift the HIGH/LOW gear change knob into the low range (see **Figure 7**). Set the forward/reverse switch to FWD.

Note: *If the knob will not rotate into gear at first, rotate the spindle by hand while holding light pressure on the knob. When the gears engage, the knob will rotate into place.*

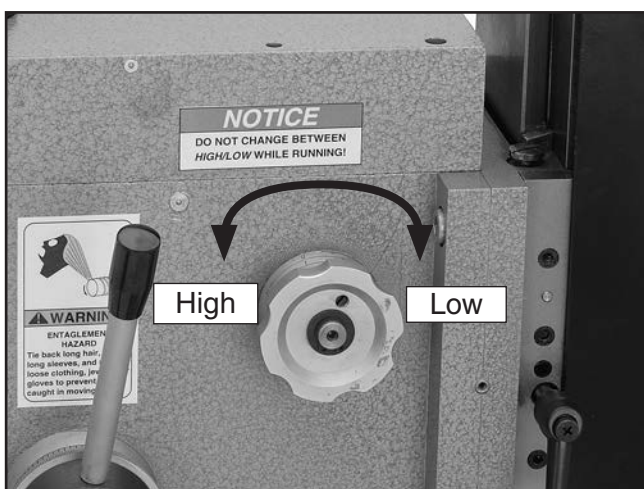

Figure 7. HIGH/LOW gear change knob.

4. Make sure all switches are **OFF** and connect the mill/drill to the power source.
5. Turn the main power switch **ON** & Spindle RPM control **ON** and let the mill run for a minimum of 10 minutes on a low speed. The mill/drill should run smoothly with minimal noise and vibration.

—If you suspect the mill/drill is not working correctly, shut the mill/drill **OFF** and correct the problem before proceeding further.

—If the mill/drill is running smoothly, proceed.

NOTICE

DO NOT attempt to change between high and low speed ranges with the spindle ON. Damage to the spindle gearing will occur.

6. Slowly increase the RPM and allow it to run at a medium RPM for another ten minutes.
7. Slowly increase the RPM and allow it to run at a high RPM for another ten minutes.
8. Turn the mill/drill **OFF**. Switch to the high range and repeat **Steps 4–6**.
9. Set the forward/reverse switch to REV and repeat the previous process.

NOTICE

Failure to follow start up and spindle break-in procedures will likely cause rapid deterioration of spindle and other related parts.



Drill Chuck Removal

The Model G0463 may have shipped with the drill chuck installed in the spindle. If this is the case, go ahead and remove the chuck and arbor at this time.

Tools Needed:	Qty
Brass Hammer	1
Pin Spanner.....	1
Wrench 17/19mm.....	1

To remove the chuck and arbor from the spindle:

1. UNPLUG THE MILL/DRILL!
2. Remove the safety cap that covers the drawbar.
3. Lock the quill in place with the quill lock.
4. Insert the pin spanner into the two holes at the bottom of the spindle. This will keep the spindle from turning, and allow you to loosen the drawbar (see **Figure 8**).

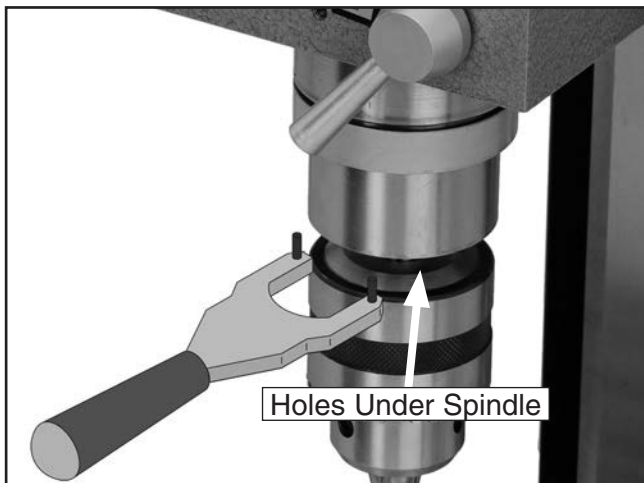

Figure 8. Spindle holes.

5. Using the 17mm wrench, loosen the drawbar but DO NOT remove it.

NOTICE

DO NOT completely unscrew the drawbar before striking it with the hammer. You will damage the threads on the drawbar and the arbor.

6. Tap the top of the drawbar with the hammer. This will unseat the taper of the arbor and the spindle (see **Figure 9**).



Figure 9. Striking the drawbar.

7. Hold one hand under the chuck and finish loosening the drawbar by hand until it falls out of the spindle.

Note: *The chuck is attached to the arbor using a JT6 taper. This attachment is considered to be semi-permanent. There should be no need to remove the chuck from the arbor. Inspect the chuck from time to time to make sure it is still tight on the arbor. If it is loose, use an dead-blow or other soft headed hammer to re-seat the taper.*



R-8 Collets

The Model G0463 features an R-8 spindle taper, which only accepts R-8 collets. R-8 collets come in many sizes, typically ranging from 1/16" to 7/8" and 3mm to 20mm. You will need a collet to match the diameter of the shank of the tool you want to hold.

To install the R-8 collet:

1. UNPLUG THE MILL/DRILL!
2. Remove the drawbar cap.
3. Carefully clean the surface of the collet and spindle taper. Ensure that it is free of debris, oil and grease of any kind.
4. Insert the cutting tool into the collet.
5. Insert the collet up into the spindle taper.
6. Slide the collet the rest of the way in until it makes contact with the threads at the end of the drawbar.
7. Using your fingers, thread the drawbar into the collet until the collet draws up into the spindle taper.
8. While supporting the tool in the collet with one hand, tighten the drawbar with the 17mm wrench in your opposite hand.

Note: *Do not overtighten the drawbar. Overtightening makes collet removal difficult and causes damage to the drawbar threads, collet, and the spindle taper. Keep in mind the taper keeps the collet and tool in place. The drawbar simply aids in seating the taper.*

To remove the collet:

1. UNPLUG THE MILL/DRILL!
2. Tighten the headstock lock.



3. Protect the table surface with a piece of cardboard or hold the cutter or tool with a shop towel to prevent it from falling out of the collet.
4. Using the 17mm wrench, loosen the drawbar but DO NOT remove it.



5. Using the brass hammer, tap the drawbar to unseat the taper.
6. Unscrew the rest of the drawbar by hand and remove the collet.

Note: *When not in use, always remove collets and cutting tools from the spindle taper. Oxidation may cause the collet to seize and make it hard to remove later.*



SECTION 4: OPERATIONS

Operation Safety

!WARNING

Damage to your eyes, lungs, and ears could result from using this machine without proper protective gear. Always wear safety glasses, a respirator, and hearing protection when operating this machine.

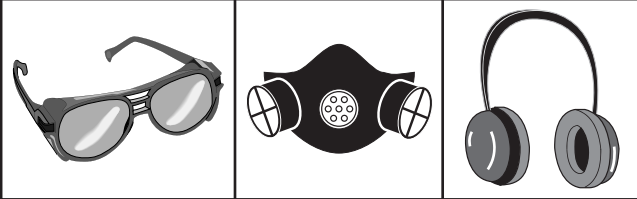

!WARNING

Loose hair and clothing could get caught in machinery and cause serious personal injury. Keep loose clothing and long hair away from moving machinery.

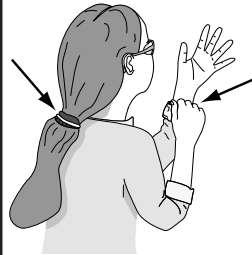

NOTICE

If you have never used this type of machine or equipment before, WE STRONGLY RECOMMEND that you read books, trade magazines, or get formal training before beginning any projects. Regardless of the content in this section, Grizzly Industrial will not be held liable for accidents caused by lack of training.

Power Controls

It is vital that you become familiar with the power controls before operating the Model G0463. Three separate switches control the power on the mill/drill (see **Figure 10**).

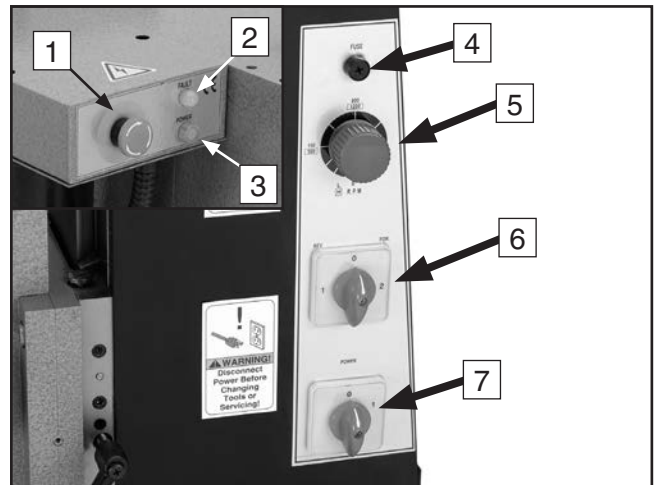

Figure 10. Control panel components.

1. **EMERGENCY STOP Button:** Immediately disconnects power to the system. Once pressed, this button must be twisted until it pops out to return power to the switches. The **FAULT INDICATOR Light** will turn on and the **MAIN POWER Switch** needs to be turned OFF.
2. **FAULT INDICATOR Light:** Indicates a circuit interruption due to a switch being out of proper position. Turn all switches OFF when lit.
3. **POWER INDICATOR Light:** Shines when the system power is ON.
4. **Fuse Socket:** Houses a 10 Amp system fuse.



5. SPINDLE RPM Control Knob: Turns the spindle **ON** and controls the spindle RPM in both speed ranges.
6. FORWARD/NEUTRAL/REVERSE Switch: Changes spindle rotational direction.
7. MAIN POWER Switch: This switch delivers power to the system.

Power Shutdown

It is important to shut the power **OFF** when the mill/drill is not in use. Leaving the power **ON** keeps the circuit board cooling fan running. This will cause unnecessary wear on the fan and electrical system.

To completely shut the system power **OFF**:

1. Turn the SPINDLE RPM Control Knob OFF.
2. Turn the MAIN POWER Switch OFF.
3. Press the EMERGENCY STOP Button. At this point the green power light and the amber fan power light should not be lit.

Spindle & Headstock Controls

The Model G0463 spindle height is controlled like a drill press (see **Figure 11**).

To use the rapid downfeed:

1. Make sure the quill lock is released and the headstock is locked in position.
2. Turn the quill feed levers to lower and raise the spindle.

Note: For maximum rigidity and accuracy when milling, keep the spindle retracted and locked inside the head as far as possible.

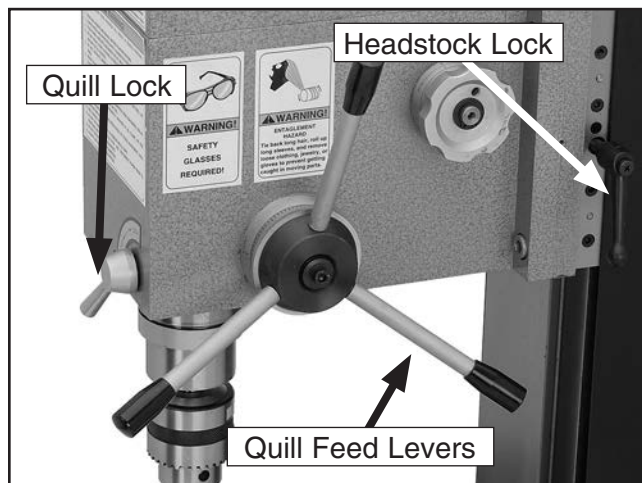

Figure 11. Spindle controls.

The headstock moves on the column in the vertical (Z) axis and is controlled by a handwheel.

To move the headstock:

1. Unlock the headstock lock.
2. Turn the vertical (Z) axis handwheel shown in **Figure 12** to raise and lower the headstock.

Note: For maximum rigidity and accuracy when milling, make sure you keep the headstock locked in position.

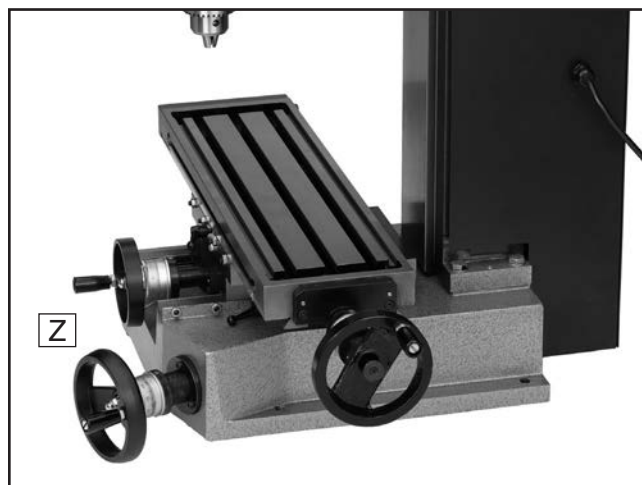

Figure 12. Z axis control.

Table Travel

The mill/drill table can be moved in the X and Y axis.

Longitudinal Feed

The longitudinal feed or (X-axis) is moved by a handwheel in **Figure 13** at the end of the table. The handwheel will move the table in both directions side-to-side. One complete revolution of the handwheel moves the longitudinal feed 0.100". There is also a scale on the front of the table for use when a tight tolerance is not required. The longitudinal feed can be locked in position by a table lock located on the front of the table (see **Figure 14**).

Cross Feed

The cross feed or (Y-axis) in **Figure 13**, is moved with the handwheel on the front of the table base. One complete revolution of the handwheel moves the cross slide 0.100". The cross feed can be locked into position by a table lock located on the right side of the cross slide underneath the table (see **Figure 14**).

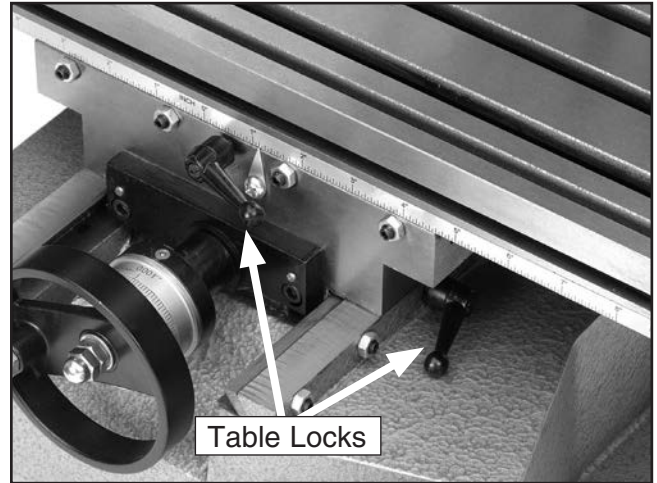

Figure 14. Table locks.

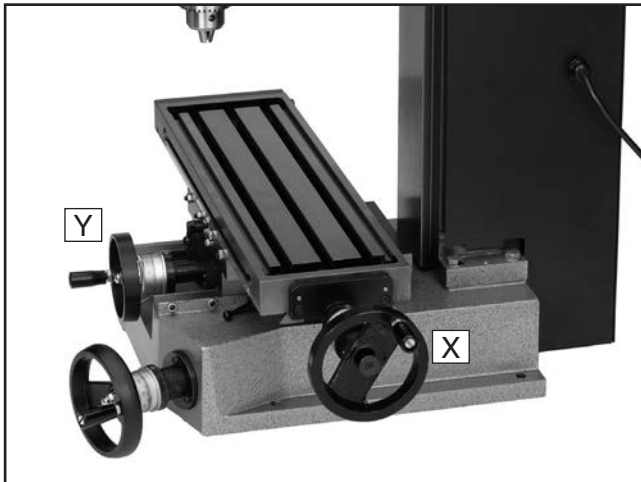

Figure 13. X & Y Handwheels.



Setting RPM

Closely follow the proper cutting speed and proper feed to reduce undue strain on all moving parts and for operator safety.

Prior to machining, you need to determine the RPM needed to cut your workpiece, and then set the RPM on the machine.

To determine the needed RPM:

1. Use the table in **Figure 15** to determine the cutting speed required for the material of your workpiece.
2. Measure the diameter of your cutting tool in inches.
3. Use the following formula to determine the needed RPM for your operation:

$$(\text{Cutting Speed} \times 4) / \text{Tool Diameter} = \text{RPM}$$

Cutting Speeds for High Speed Steel (HSS) Cutting Tools	
Workpiece Material	Cutting Speed (sfm)
Aluminum & alloys	300
Brass & Bronze	150
Copper	100
Cast Iron, soft	80
Cast Iron, hard	50
Mild Steel	90
Cast Steel	80
Alloy Steel, hard	40
Tool Steel	50
Stainless Steel	60
Titanium	50
Plastics	300-800
Wood	300-500

Note: For carbide cutting tools, double the cutting speed. These values are a guideline only. Refer to the *MACHINERY'S HANDBOOK* for more detailed information.

Figure 15. Cutting speed table for HSS cutting tools.

WARNING

Failure to follow RPM and Feed Rate Guidelines may threaten operator safety from ejected parts or broken tools.

NOTICE

Failure to follow RPM and Feed Rate Guidelines will put undue strain on moving parts, shorten tool life, and create poor workpiece results.



SECTION 5: ACCESSORIES

G9765—9-PC. Ball End Mill Set

Features 2 flute ball nose end mills. Includes the following sizes: $\frac{1}{8}$ ", $\frac{3}{16}$ ", $\frac{1}{4}$ ", $\frac{5}{16}$ ", $\frac{3}{8}$ ", $\frac{7}{16}$ ", $\frac{1}{2}$ ", $\frac{5}{8}$ " and $\frac{3}{4}$ ".

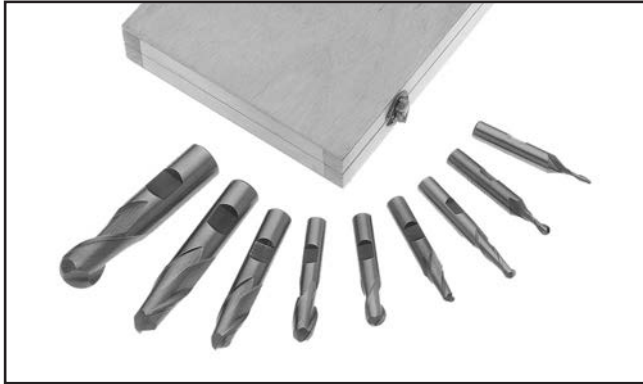

Figure 16. G9765 9 PC. Ball End Mill Set.

G9610—Test Indicator

.03" Range/.001" Resolution

G9611—Test Indicator

.008" Range/.0001" Resolution

G9612—Test Indicator

.030" Range/.0005" Resolution

These test indicators have an easy to read dial and a pivoting stylus that moves at right angles to the dial face.



Figure 17. Test Indicator.

H3022—Measurement Tool Set

Includes magnetic base, 1" dial indicator (.001"), and 6" dial caliper (.001"). The extremely low price has made this a very popular seller!



Figure 18. H3022 Measurement Tool Set.

G9002—2½" Swivel Base Milling Vise

G5971—3½" Swivel Base Milling Vise

G5972—4" Swivel Base Milling Vise

G5973—5" Swivel Base Milling Vise

G5974—6" Swivel Base Milling Vise

G5975—8" Swivel Base Milling Vise

Vises feature 360° rotation with fine graduations, drop forged handle, precision ground jaw faces, enclosed acme screw and detachable swivel base.



Figure 19. Swivel base milling vise.

Call 1-800-523-4777 To Order



G9324—Boring Head Combo Set

Hardened and ground adjusting screws along with a wide base design guarantee a long life and trouble-free use. Includes a 3" boring head, R-8 arbor with 1½"-18 TPI, and a 12 piece ¾" boring bar set.



Figure 20. G9324 Boring Head Combo Set.

G2861—2½" Face Mill

This 2½" Face Mill accepts four carbide inserts. Comes with an R-8 arbor.



Figure 21. G2861 Face mill.

G9760—20-PC. 2 & 4 Flute TiN End Mill Set.

Includes these sizes and styles in two and four flute styles: 3/16", 1/4", 5/16", 3/8", 7/16", 1/2", 9/16", 5/8", 3/8", 11/16", and 3/4".



Figure 22. G9760 20-PC End Mill Set.

H2689—R-8 Quick Change Collet Set

An affordable quick change collet system with ultra precision. These spring collets are hardened and ground to exacting tolerances and offer incredible holding power. This set includes an R-8 arbor and nut, spanner wrench, plastic carrying case and collets sized 1/8", 1/4", 3/8", 1/2", 5/8", 3/4", 7/8", and 1". What's more, the nut features a self-ejecting rim! A set like this will truly speed up any tool changing process. Drawbar size is 7/16" x 20.



Figure 23. H2689 R-8 Quick Change Collet Set.

H5685—4" Rotary Table

The perfect rotary table for all you model makers and those doing smaller precision work. Comes with clamping kit.

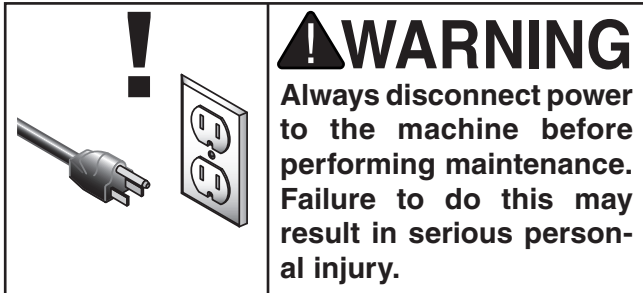

Figure 24. H5685 4" Rotary Table.

Call 1-800-523-4777 To Order



SECTION 6: MAINTENANCE



Schedule

For optimum performance from your machine, follow this maintenance schedule and refer to any specific instructions given in this section.

Daily Check:

- Mill/drill is completely powered down at the end of use.
- Excess cutting fluids and chips have been removed and unpainted surfaces are dry and protected.
- Loose mounting bolts.
- Mill/drill is clean and lubricated.
- Worn or damaged wires.
- Any other unsafe condition.

Monthly Check:

- Gibs are adjusted properly.

Unpainted Cast Iron

Protect the unpainted cast iron surfaces on the table by removing vises and fixtures daily and by wiping the table clean after every use—this ensures moisture does not remain on bare metal surfaces.

Keep tables rust-free with regular applications of products like G96® Gun Treatment, SLIPIT®, or Boeshield® T-9 (see **SECTION 5: ACCESSORIES** on **Page 22** for more details).

Lubrication

Regular lubrication will ensure your mill/drill performs at its highest potential (see **Figures 25 & 26**).

Place two to three drops of ISO 68 or SAE 20W non-detergent oil or similar lubricant directly on the ways of the cross slide and saddle. An oil bottle has been provided for this purpose.

Oil fittings are located on the tops of each handwheel and one on each side where the headstock meets the column. These should be lubricated daily with several drops oil.

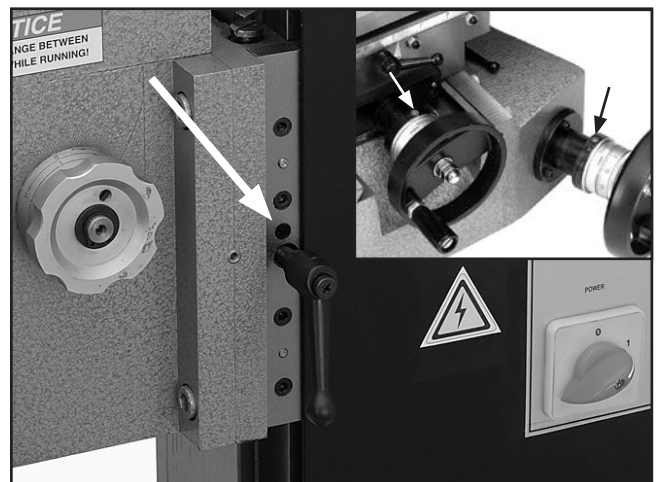

Figure 25. Column lubrication.

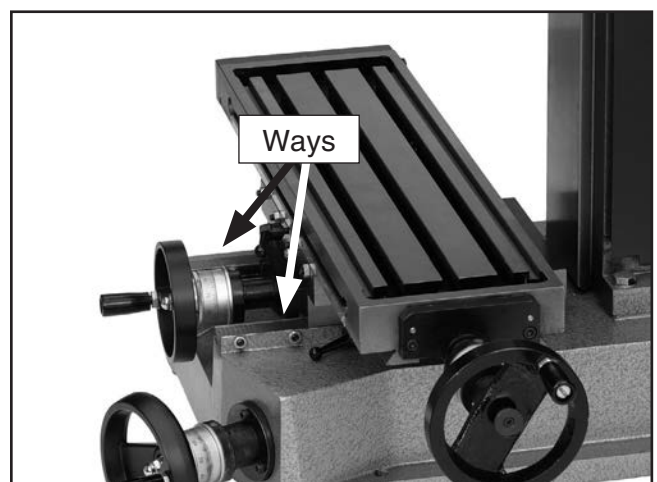

Figure 26. Table lubrication.



SECTION 7: SERVICE

About Service

Review the troubleshooting and procedures in this section to fix your machine if a problem develops. If you need replacement parts or you are unsure of your repair skills, then feel free to call our Technical Support at (570) 546-9663.

Troubleshooting



Symptom	Possible Cause	Possible Solution
Motor will not start.	<ol style="list-style-type: none"> 1. E-Stop button is pressed. 2. Open circuit in motor or loose connections. 3. Blown system fuse. 	<ol style="list-style-type: none"> 1. Twist E-Stop until it pops out. 2. Inspect all lead connections on motor for loose or open connections. 3. Replace fuse.
Motor will not start; fuses or circuit breakers blow.	<ol style="list-style-type: none"> 1. Short circuit in line cord or plug. 	<ol style="list-style-type: none"> 1. Repair or replace cord or plug for damaged insulation and shorted wires.
Motor shuts off unexpectedly.	<ol style="list-style-type: none"> 1. Motor is overloaded due to high feed rate. 2. Thermal protection unit is overheated. 	<ol style="list-style-type: none"> 1. Reduce feed rate and amount of material removed. 2. Wait for system to cool down.
Motor overheats.	<ol style="list-style-type: none"> 1. Motor overloaded. 2. Air circulation through the motor restricted. 3. Motor brushes are wearing. 	<ol style="list-style-type: none"> 1. Reduce load on motor. 2. Clean out motor to provide normal air circulation. 3. Inspect motor brushes, replace if necessary.
Motor stalls (resulting in blown fuses or tripped circuit).	<ol style="list-style-type: none"> 1. Short circuit in motor or loose connections. 2. Low voltage. 3. Incorrect fuses or circuit breakers in power line. 4. Motor overloaded. 	<ol style="list-style-type: none"> 1. Repair or replace connections on motor for loose or shorted terminals or worn insulation. 2. Correct the low voltage conditions. 3. Install correct fuses or circuit breakers. 4. Reduce load on motor.
Cutter slows when cutting.	<ol style="list-style-type: none"> 1. Brushes worn. 	<ol style="list-style-type: none"> 1. Replace brushes (Page 30).
Poor surface finishes.	<ol style="list-style-type: none"> 1. Feed rate too fast. 2. Dull cutter. 3. Lock not tightened down. 4. Gibs loose. 	<ol style="list-style-type: none"> 1. Slow feed rate. 2. Always use newly sharpened cutters. 3. Tighten column and table locks when possible to maintain rigidity. 4. Adjust gibs.
Vibration when running or cutting.	<ol style="list-style-type: none"> 1. Loose table. 2. Loose gibs. 3. Feed rate too high. 	<ol style="list-style-type: none"> 1. Tighten table locks. 2. Adjust gibs. 3. Slow feed rate or adjust RPM.
Difficulty removing collet from spindle.	<ol style="list-style-type: none"> 1. Debris in spindle taper or collet taper or both. 2. Head not locked in position. 	<ol style="list-style-type: none"> 1. Keep all taper surfaces spotlessly clean. 2. Lock head in place on column.



Adjusting Gibs

The function of the gibs is to take out play in the table, and cross slide, and column without causing the slides to bind. The gibs are pre-adjusted at the factory and should not need further adjustment until many hours of machine use. If the movement seems too tight at first, make sure the locks are fully released. Next, make sure the bedways are thoroughly cleaned of rust preventative and lubricated with oil.

Tools Needed:	Qty
Wrench 10mm.....	1
Hex Wrench 3mm.....	1

Each gib has multiple lock nuts and set screws that need to be adjusted. Make your adjustments equally and in small increments.

To adjust the gibs: (see Figure 27)

1. UNPLUG THE MILL/DRILL!
2. Loosen the lock nuts.
3. Move the table and slightly tighten each set screw. When properly adjusted, the gib should offer slight resistance without binding.
4. Tighten the lock nuts.

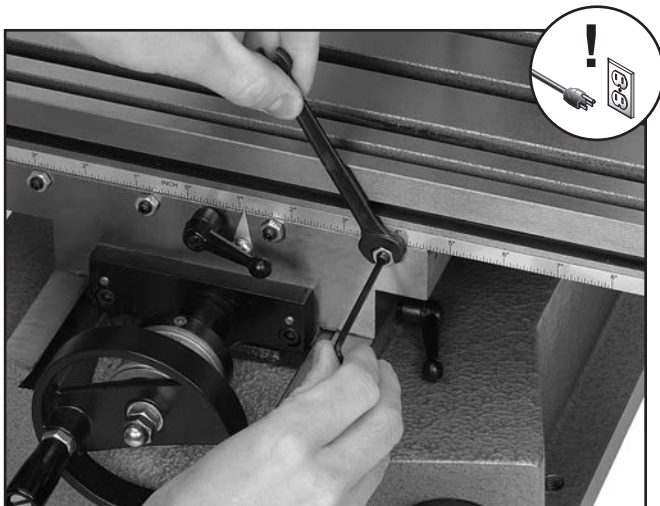

Figure 27. Gib adjustment.

Replacing Motor Brushes & Fuse

After some period of time, the carbon brushes on the DC motor will need to be replaced. Always replace the brushes in pairs. Use part # P0463242.

To replace the motor brushes:

1. UNPLUG THE MILL/DRILL!
2. Remove and replace the spring and carbon brush.

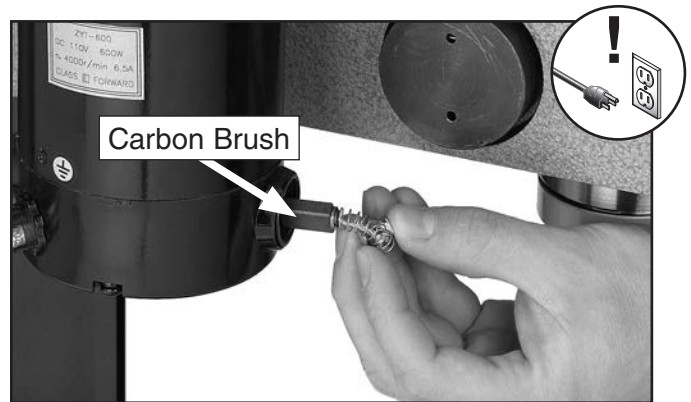

Figure 28. Carbon brush removal.

A 10 Amp fuse is housed in the body near the main controls.

To replace the fuse:

1. UNPLUG THE MILL/DRILL!
2. Remove and replace the fuse from the fuse cradle (see Figure 29).



Figure 29. Fuse replacement.



Electrical Components



Figure 30. Circuit board.



Figure 33. RPM control.

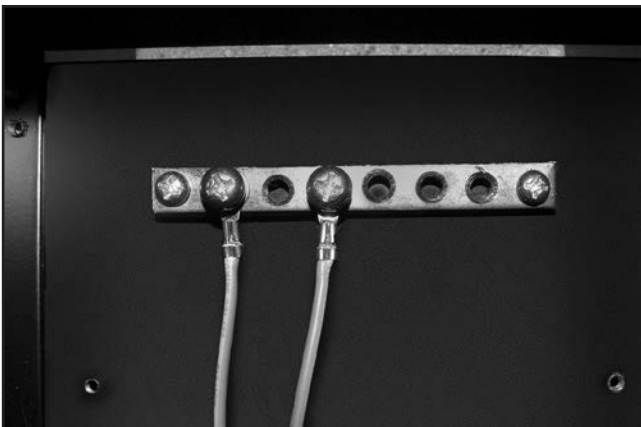

Figure 31. Equipment grounds inside column.



Figure 34. Forward/Reverse switch.

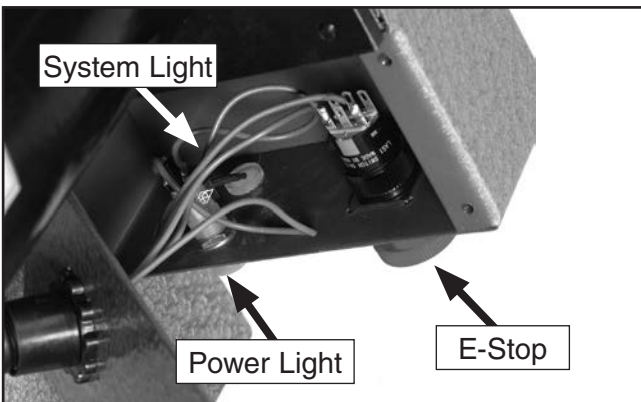

Figure 32. E-Stop and indicator lights.



Figure 35. Main power switch.



Wiring Diagram

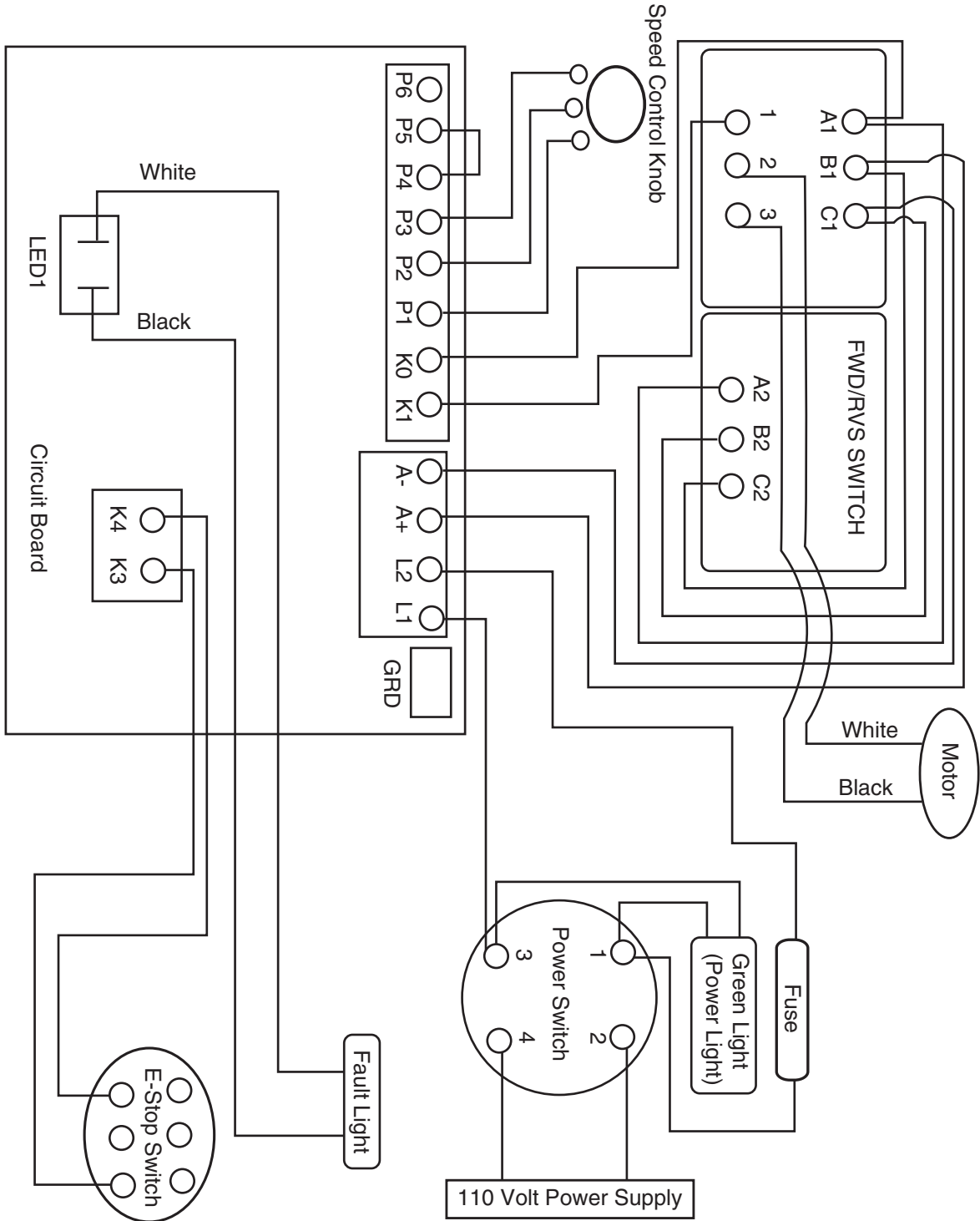

Parts Breakdown

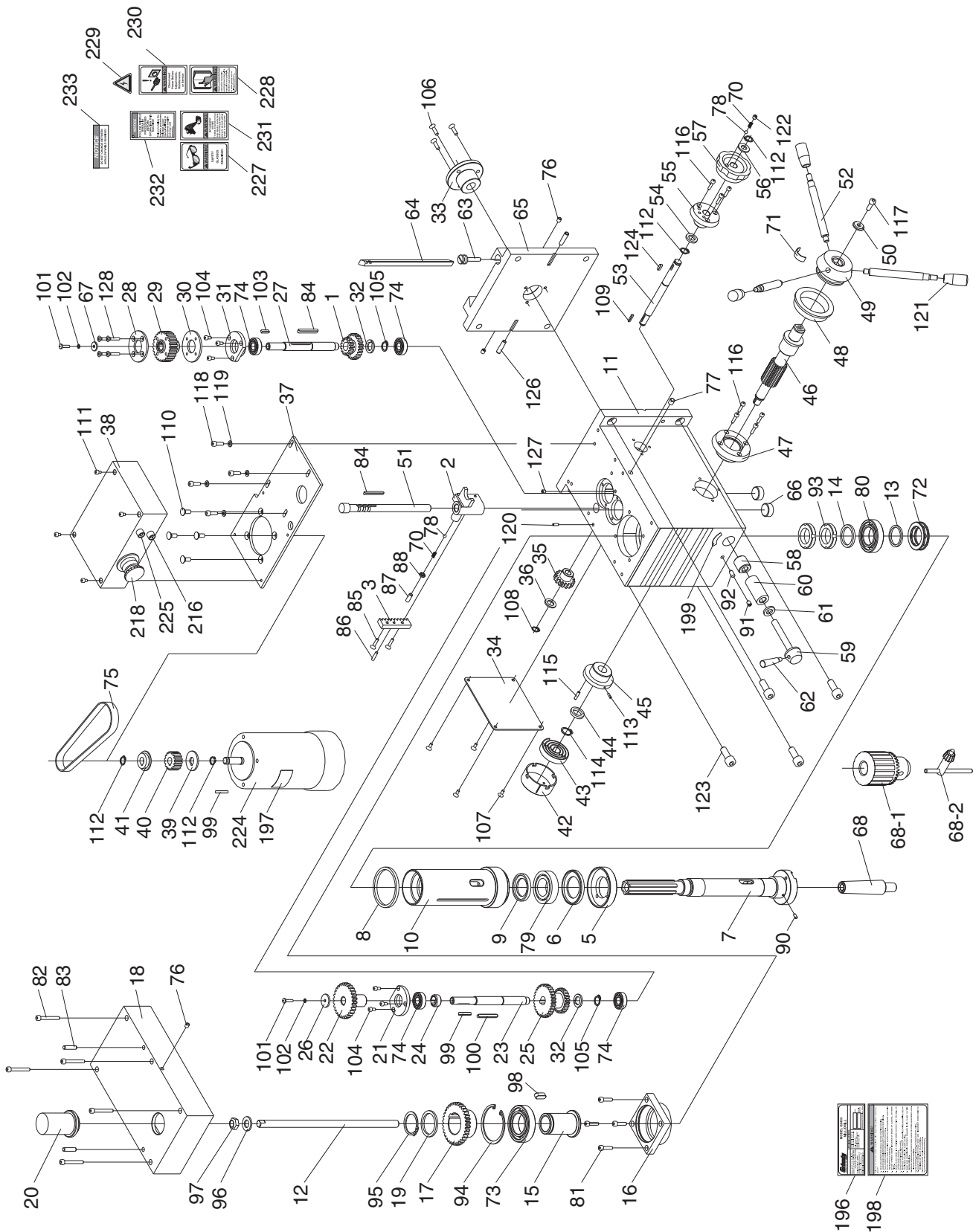

Parts Breakdown

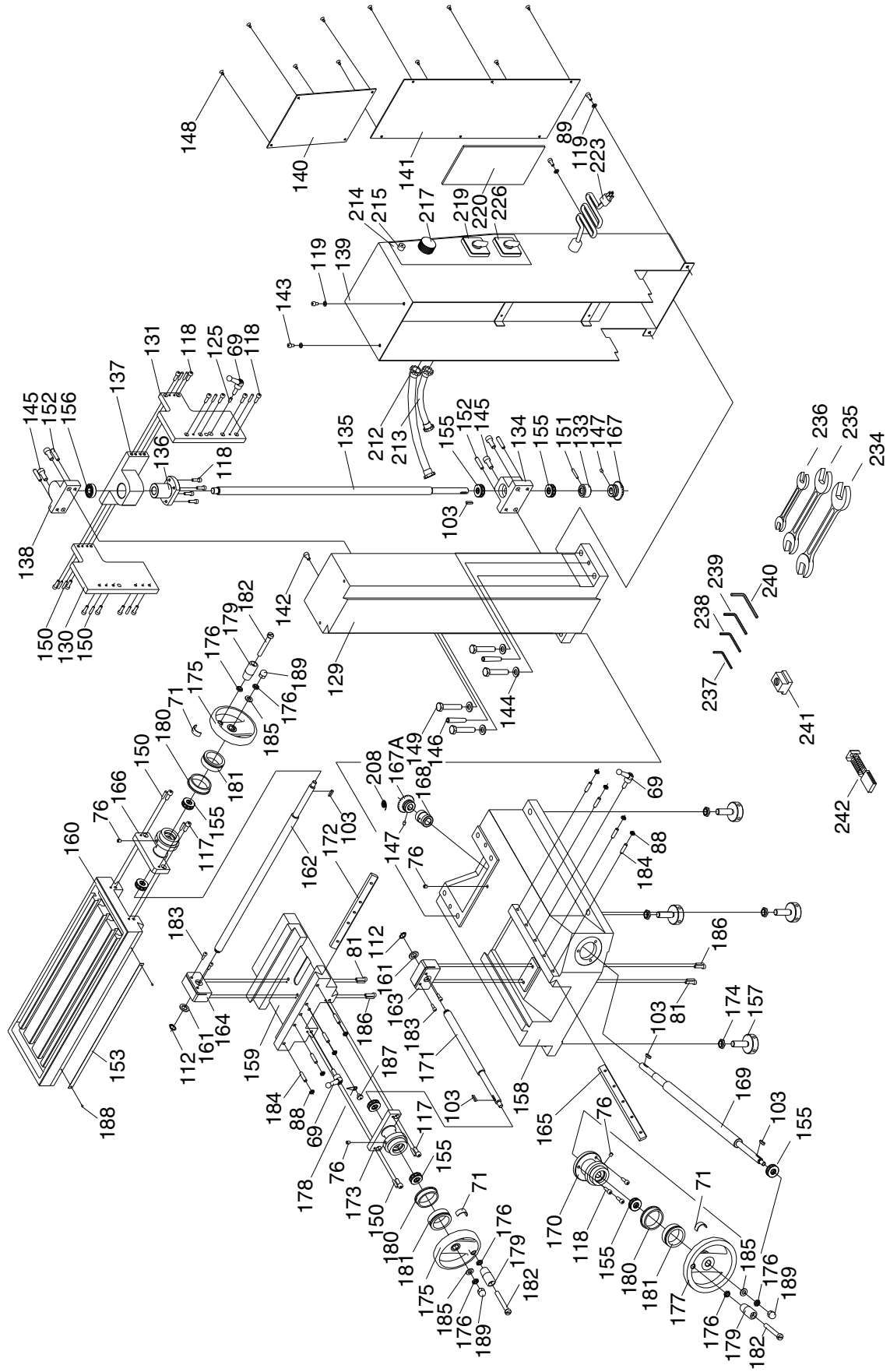

Parts List

REF	PART #	DESCRIPTION
1	P0463001	TRANSMISSION GEAR
2	P0463002	DIAL FORK
3	P0463003	SMALL GEAR RACK
5	P0463005	DUST CAP
6	P0463006	OIL SEAL
7	P0463007	SPINDLE
8	P0463008	SLEEVE
9	P0463009	OIL SEAL
10	P0463010	QUILL
11	P0463011	HEAD CASTING
12	P0463012	DRAWBAR
13	P0463013	SPACER
14	P0463014	SPACER
15	P0463015	SLEEVE
16	P0463016	BEARING SEAT
17	P0463017	SPINDLE GEAR
18	P0463018	COVER
19	P0463019	SPACER
20	P0463020	DRAWBAR CAP
21	P0463021	BEARING SEAT
22	P0463022	GEAR
23	P0463023	SHAFT
24	P0463024	SLEEVE
25	P0463025	TRANSMISSION GEAR
26	P0463026	FENDER WASHER
27	P0463027	SHAFT
28	P0463028	UPPER FLANGE
29	P0463029	GEAR
30	P0463030	LOWER FLANGE
31	P0463031	BEARING SEAT
32	P0463032	SPACER
33	P0463033	FLANGE
34	P0463034	COVER
35	P0463035	GEAR
36	P0463036	FLAT WASHER 12MM
37	P0463037	MOTOR FIXED TRAY
38	P0463038	CONTROL BOX
39	P0463039	SPACER
40	P0463040	GEAR
41	P0463041	SPACER
42	P0463042	SPRING COVER
43	P0463043	FLAT COIL SPRING
44	P0463044	BUSHING
45	P0463045	LEFT SUPPORT FLANGE
46	P0463046	PINION
47	P0463047	RIGHT SUPPORT FLANGE
48	P0463048	COLLAR
49	P0463049	HANDLE HUB
50	P0463050	CAP
51	P0463051	DIAL FORK SHAFT

REF	PART #	DESCRIPTION
52	P0463052	QUILL HANDLE
53	P0463053	SHAFT
54	P0463054	BUSHING
55	P0463055	RIGHT SUPPORT FLANGE
56	P0463056	BUSHING
57	P0463057	HIGH/LOW KNOB
58	P0463058	SPINDLE LOCK SLEEVE II
59	P0463059	SPINDLE LOCK HANDLE
60	P0463060	SPINDLE LOCK SLEEVE I
61	P0463061	SPACER
62	P0463062	SMALL HANDLE
63	P0463063	GIB ADJUST SCREW
64	P0463064	GIB
65	P0463065	COLUMN PLATE
66	P0463066	END CAP
67	P0463067	CAP
68	P0463068	ARBOR R8/JT6
68-1	P0463068-1	CHUCK 3-16MM/JT6
68-2	P0463068-2	CHUCK KEY
69	P0463069	SMALL HANDLE
70	P0463070	COMPRESSION SPRING
71	P0463071	FLAT SPRING
72	P0463072	BEARING 8106
73	P0463073	BEARING 6007
74	P0463074	BEARING 6001
75	P0463075	TIMING BELT
76	P0463076	OIL FITTING
77	P0463077	OIL FITTING
78	P0463078	STEEL BALL
79	P0463079	BEARING Z007106
80	P0463080	BEARING 6006
81	P0463081	CAP SCREW M5-.8 X 20
82	P0463082	CAP SCREW M5-.8 X 40
83	P0463083	SOLID PIN 6 X 25
84	P0463084	KEY 4 X 4 X 40
85	P0463085	PHLP HD SCR M4-.7 X 16
86	P0463086	ROLL PIN 4 X 16
87	P0463087	SET SCREW M6-1 X 16
88	P0463088	HEX NUT M6-1
89	P0463089	CAP SCREW M5-.8 X 12
90	P0463090	ROLL PIN 4 X 8
91	P0463091	SET SCREW M5-.8 X 12
92	P0463092	SET SCREW M6-1 X 12
93	P0463093	LOCK RING M27 -1.5
94	P0463094	INT RETAINING RING 62MM
95	P0463095	EXT RETAINING RING 35MM
96	P0463096	FLAT WASHER 12MM
97	P0463097	HEX NUT M12-1.75
98	P0463098	KEY 8 X 8 X 20



Parts List

REF	PART #	DESCRIPTION
99	P0463099	KEY 4 X 4 X 25
100	P0463100	KEY 5 X 5 X 20
101	P0463101	CAP SCREW M4-.7 X 16
102	P0463102	LOCK WASHER 4MM
103	P0463103	KEY 4 X 4 X 16
104	P0463104	CAP SCREW M4-.7 X 8
105	P0463105	EXT RETAINING RING 16MM
106	P0463106	PHLP HD SCR M5-.8 X 16
107	P0463107	PHLP HD SCR M4-.7 X 8
108	P0463108	EXT RETAINING RING 10MM
109	P0463109	KEY 3 X 3 X 16
110	P0463110	PHLP HD SCR M6-1 X 16
111	P0463111	CAP SCREW M4-.7 X 6
112	P0463112	EXT RETAINING RING 16MM
113	P0463113	ROLL PIN 3 X 10
114	P0463114	EXT RETAINING RING 16MM
115	P0463115	ROLL PIN 4 X 16
116	P0463116	CAP SCREW M4-.7 X 16
117	P0463117	CAP SCREW M6-1 X 16
118	P0463118	CAP SCREW M5-.8 X 16
119	P0463119	FLAT WASHER 5MM
120	P0463120	ROLL PIN 4 X 10
121	P0463121	LONG HANDLE SLEEVE
122	P0463122	SET SCREW M6-1 X 6
123	P0463123	CAP SCREW M10-1.5 X 25
124	P0463124	KEY 4 X 4 X 12
125	P0463125	ROLL PIN 5 X 10
126	P0463126	ROLL PIN 6 X 26
127	P0463127	SET SCREW M5-.8 X 6
128	P0463128	PHLP HD SCR M4-.7 X 20
129	P0463129	COLUMN
130	P0463130	LEFT SIDE PLATE
131	P0463131	RIGHT SIDE PLATE
133	P0463133	LIMIT SLEEVE
134	P0463134	LOWER BEARING SEAT
135	P0463135	VERTICAL LEAD SCREW
136	P0463136	VERTICAL LEAD NUT
137	P0463137	SUPPORT
138	P0463138	UPPER BEARING SEAT
139	P0463139	REAR CABINET
140	P0463140	SMALL COVER
141	P0463141	LARGE COVER
142	P0463142	CAP SCREW M6-1 X 10
143	P0463143	CAP SCREW M5-.8 X 8
144	P0463144	FLAT WASHER 10MM
145	P0463145	CAP SCREW M8-1.25 X 20
146	P0463146	ROLL PIN 8 X 45
147	P0463147	SET SCREW M5-.8 X 8
148	P0463148	PHLP HD SCR M4-.7 X 6
149	P0463149	HEX BOLT M10-1.5 X 50

REF	PART #	DESCRIPTION
150	P0463150	ROLL PIN 4 X 20
151	P0463151	ROLL PIN 4 X 25
152	P0463152	ROLL PIN 4 X 30
153	P0463153	RULER
155	P0463155	BEARING 8101
156	P0463156	BEARING 6001
157	P0463157	ADJUSTABLE FOOT
158	P0463158	BASE
159	P0463159	SADDLE
160	P0463160	WORKTABLE
161	P0463161	SPACER
162	P0463162	X-AXIS FEED SCREW
163	P0463163	Y-AXIS FEED SCREW NUT
164	P0463164	X-AXIS FEED SCREW NUT
165	P0463165	Y-AXIS GIB
166	P0463166	X-AXIS BEARING SEAT
167	P0463167	GEAR 48T LARGE
167A	P0463167A	GEAR SMALL 24T
168	P0463168	SLEEVE
169	P0463169	Z-AXIS SHAFT
170	P0463170	SUPPORT FLANGE
171	P0463171	Y-AXIS FEED SCREW
172	P0463172	X-AXIS GIB
173	P0463173	Y-AXIS BEARING SEAT
174	P0463174	HEX NUT M12-1.75
175	P0463175	HANDWHEEL
176	P0463176	HEX NUT M8-1.25
177	P0463177	HANDWHEEL
178	P0463178	POINTER
179	P0463179	HANDLE SLEEVE
180	P0463180	INLAY RING
181	P0463181	GRADUATED DIAL
182	P0463182	SHOULDER SCREW M8-1.25 X 55
183	P0463183	CAP SCREW M4-.7 X 12
184	P0463184	SET SCREW M6-1 X 25
185	P0463185	FLAT WASHER 8MM
186	P0463186	ROLL PIN 3 X 20
187	P0463187	PHLP HD SCR M6-1 X 6
188	P0463188	RIVET
189	P0463189	CAP NUT
196	P0463196	MACHINE ID LABEL I
197	P0463197	MOTOR LABEL
198	P0463198	MACHINE ID LABEL II
199	P0463199	LOCK LABEL
208	P0463208	FINE LEAD WIRE 1 X 85
212	P0463212	STRAIN RELIEF
213	P0463213	FLEX CONDUIT
214	P0463214	SWITCH LABEL
215	P0463215	FUSE BOX
216	P0463216	POWER INDICATING LAMP



Parts List

REF	PART #	DESCRIPTION
217	P0463217	RPM CONTROLER
218	P0463218	EMERGENCY STOP SWITCH
219	P0463219	REV/OFF/FWD SWITCH
220	P0463220	PC BOARD
223	P0463223	POWER CORD
224	P0463224	MOTOR
225	P0463225	FAULT INDICATING LAMP
226	P0463226	POWER SWITCH
227	P0463227	SAFETY GLASSES LABEL
228	P0463228	READ MANUAL LABEL
229	P0463229	ELECTRICITY LABEL
230	P0463230	UNPLUG 110V LABEL
231	P0463231	ENTAGLEMENT LABEL

REF	PART #	DESCRIPTION
232	P0463232	SPINDLE BREAK-IN LABEL
233	P0463233	CHANGE GEARS LABEL
234	P0463234	WRENCH 17 X 19
235	P0463235	WRENCH 12 X 14
236	P0463236	WRENCH 8 X 10
237	P0463237	HEX WRENCH 3MM
238	P0463238	HEX WRENCH 4MM
239	P0463239	HEX WRENCH 5MM
240	P0463240	HEX WRENCH 6MM
241	P0463241	T-NUT 3/8"
242	P0463242	MOTOR BRUSH
243	P0463243	PIN SPANNER WRENCH

WARNING

Safety labels warn about machine hazards and ways to prevent injury. The owner of this machine **MUST** maintain the original location and readability of the labels on the machine. If any label is removed or becomes unreadable, **REPLACE** that label before using the machine again. Contact Grizzly at (800) 523-4777 or www.grizzly.com to order new labels.







WARRANTY CARD

Name _____
 Street _____
 City _____ State _____ Zip _____
 Phone # _____ Email _____
 Model # _____ Order # _____ Serial # _____

The following information is given on a voluntary basis. It will be used for marketing purposes to help us develop better products and services. **Of course, all information is strictly confidential.**

1. How did you learn about us?

Advertisement Friend Catalog
 Card Deck Website Other:

2. Which of the following magazines do you subscribe to?

<input type="checkbox"/> Cabinetmaker & FDM	<input type="checkbox"/> Popular Science	<input type="checkbox"/> Wooden Boat
<input type="checkbox"/> Family Handyman	<input type="checkbox"/> Popular Woodworking	<input type="checkbox"/> Woodshop News
<input type="checkbox"/> Hand Loader	<input type="checkbox"/> Precision Shooter	<input type="checkbox"/> Woodsmith
<input type="checkbox"/> Handy	<input type="checkbox"/> Projects in Metal	<input type="checkbox"/> Woodwork
<input type="checkbox"/> Home Shop Machinist	<input type="checkbox"/> RC Modeler	<input type="checkbox"/> Woodworker West
<input type="checkbox"/> Journal of Light Cont.	<input type="checkbox"/> Rifle	<input type="checkbox"/> Woodworker's Journal
<input type="checkbox"/> Live Steam	<input type="checkbox"/> Shop Notes	<input type="checkbox"/> Other:
<input type="checkbox"/> Model Airplane News	<input type="checkbox"/> Shotgun News	
<input type="checkbox"/> Old House Journal	<input type="checkbox"/> Today's Homeowner	
<input type="checkbox"/> Popular Mechanics	<input type="checkbox"/> Wood	

3. What is your annual household income?

\$20,000-\$29,000 \$30,000-\$39,000 \$40,000-\$49,000
 \$50,000-\$59,000 \$60,000-\$69,000 \$70,000+

4. What is your age group?

20-29 30-39 40-49
 50-59 60-69 70+

5. How long have you been a woodworker/metalworker?

0-2 Years 2-8 Years 8-20 Years 20+ Years

6. How many of your machines or tools are Grizzly?

0-2 3-5 6-9 10+

7. Do you think your machine represents a good value? Yes No

8. Would you recommend Grizzly Industrial to a friend? Yes No

9. Would you allow us to use your name as a reference for Grizzly customers in your area?

Note: We never use names more than 3 times. Yes No

10. Comments: _____

CUT ALONG DOTTED LINE

FOLD ALONG DOTTED LINE



Place
Stamp
Here



GRIZZLY INDUSTRIAL, INC.
P.O. BOX 2069
BELLINGHAM, WA 98227-2069



FOLD ALONG DOTTED LINE

Send a Grizzly Catalog to a friend:

Name _____

Street _____

City _____ State _____ Zip _____

TAPE ALONG EDGES--PLEASE DO NOT STAPLE

WARRANTY AND RETURNS

Grizzly Industrial, Inc. warrants every product it sells for a period of **1 year** to the original purchaser from the date of purchase. This warranty does not apply to defects due directly or indirectly to misuse, abuse, negligence, accidents, repairs or alterations or lack of maintenance. This is Grizzly's sole written warranty and any and all warranties that may be implied by law, including any merchantability or fitness, for any particular purpose, are hereby limited to the duration of this written warranty. We do not warrant or represent that the merchandise complies with the provisions of any law or acts unless the manufacturer so warrants. In no event shall Grizzly's liability under this warranty exceed the purchase price paid for the product and any legal actions brought against Grizzly shall be tried in the State of Washington, County of Whatcom.

We shall in no event be liable for death, injuries to persons or property or for incidental, contingent, special, or consequential damages arising from the use of our products.

To take advantage of this warranty, contact us by mail or phone and give us all the details. We will then issue you a "Return Number," which must be clearly posted on the outside as well as the inside of the carton. We will not accept any item back without this number. Proof of purchase must accompany the merchandise.

The manufacturers reserve the right to change specifications at any time because they constantly strive to achieve better quality equipment. We make every effort to ensure that our products meet high quality and durability standards and we hope you never need to use this warranty.

Please feel free to write or call us if you have any questions about the machine or the manual.

Thank you again for your business and continued support. We hope to serve you again soon.

grizzly.com[®]
TOOL WEBSITE

Buy Direct and Save with Grizzly[®] – Trusted, Proven and a Great Value!
~Since 1983~

*Visit Our Website Today For
Current Specials!*

**ORDER
24 HOURS A DAY!
1-800-523-4777**

